



D E S I G N E D T O L E A D

TWZ Series

Oil-Fired Hot Water Boilers

INSTALLATION INSTRUCTIONS

These instructions must be affixed on or adjacent to the boiler

Models:

- TWZ065
- TWZ075
- TWZ100
- TWZ090
- TWZ125
- TWZ150
- TWZ120
- TWZ175
- TWZ200

WARNING: Improper installation, adjustment, alteration, service or maintenance can cause property damage, injury, or loss of life. For assistance or additional information, consult a qualified installer, service agency or the oil supplier. Read these instructions carefully before installing.



Manufacturer of Hydronic Heating Products
P.O. Box 14818 3633 I. Street
Philadelphia, PA 19134
www.crownboiler.com



WARNINGS FOR THE HOMEOWNER

FOLLOW ALL INSTRUCTIONS and warnings printed in this manual and posted on the boiler.

INSPECT THE BOILER, BURNER AND CONTROLS ANNUALLY. To keep your boiler safe and efficient, have a service technician follow the Service checklist near the end of this manual.

IF YOU ARE NOT QUALIFIED to install or service boilers, do not install or service this one.

THE BOILER MAY LEAK WATER at the end of its useful life. Be sure to protect walls, carpets, and valuables from water that could leak from the boiler.

PROTECT YOUR HOME IN FREEZING WEATHER. A power outage, safety lockout, or component failure will prevent your boiler from lighting. In winter, your pipes may freeze and cause extensive property damage. Do not leave the heating system unattended during cold weather

unless alarms or other safeguards are in place to prevent such damage

DO NOT BLOCK AIR FLOW into or around the boiler. Insufficient air may cause the boiler to produce carbon monoxide or start a fire.

KEEP FLAMMABLE LIQUIDS AWAY from the boiler, including paint, solvents, and gasoline. The boiler may ignite the vapors from the liquids causing explosion or fire.

KEEP CHILDREN AND PETS away from hot surfaces of the boiler, boiler piping, and vent pipe.

CARBON MONOXIDE (CO) is an odorless, deadly gas that may be introduced into your home by any malfunctioning fuel-burning product or vent system failure. Consider installing CO alarms near bedrooms in all levels of the building to warn you and your family of potential CO exposure.



WARNINGS FOR THE INSTALLER

READ THIS ENTIRE MANUAL before attempting installation, start-up, or service. Improper installation, adjustment, alteration, service, or maintenance may cause serious property damage, personal injury, or death.

DO NOT DISCONNECT PIPE FITTINGS on the boiler or in the heating system without first verifying that the system is cool and free of pressure and that your clothing will protect you from a release of hot water or steam. Do not rely solely on the boiler's temperature and pressure gage when making this judgment.

USE PROPER PERSONAL PROTECTION EQUIPMENT when servicing or working near the boiler. Materials of construction, flue products, and fuel contain alumina, silica, heavy metals, carbon monoxide, nitrogen oxides, and/or other toxic or harmful substances that can be hazardous to health and life and that are known to the State of California to cause cancer, birth defects, and other reproductive harm.

INSTALL ALL GUARDS, cover plates, and enclosures before operating the boiler.

SIZE THE BOILER PROPERLY relative to the design heat load or, if using domestic hot water priority, the peak hot water load, whichever is larger. A grossly oversized boiler will cycle excessively and this will lead to premature failure of the boiler and its components. Our warranty does not apply to damage from excessive cycling.

ADHERE TO ALL LOCAL CODE REQUIREMENTS. Contact your local code inspector prior to installation. In the absence of a local code, adhere to the latest editions of the *Installation of Oil Burning Equipment ANSI/NFPA 31* in the USA or *CAN/CSA B139, Installation Code for Oil Burning Equipment* in Canada.

ALL WIRING must comply with the *National Electrical Code ANSI/NFPA 70* (in the USA) or the *Canadian Electrical Code CSA C22.1* (in Canada) and any local regulations.

Table of Contents

I.	Product Description	3
II.	Specifications	3
III.	Before Installing	4
IV.	Locating the Boiler	5
V.	Air for Combustion & Ventilation	7
VI.	Venting	11
VII.	System Piping	13
VIII.	Tankless Heater Piping	17
IX.	Fuel Line Piping	18
X.	Wiring	21
XI.	Start-Up & Checkout	26
XII.	Operation	29
XIII.	Service & Maintenance	36
XIV.	Troubleshooting	39
XV.	Parts	42

I Product Description

The TWZ series boiler is a cast iron oil-fired water boiler designed for use in closed forced circulation heating systems. This boiler must be vented by natural draft into a lined masonry or metal chimney, or Type L vent. An adequate supply of air for combustion, ventilation and dilution of flue gases must be available in the boiler room. An optional tankless heater is available to generate domestic hot water.

II Specifications

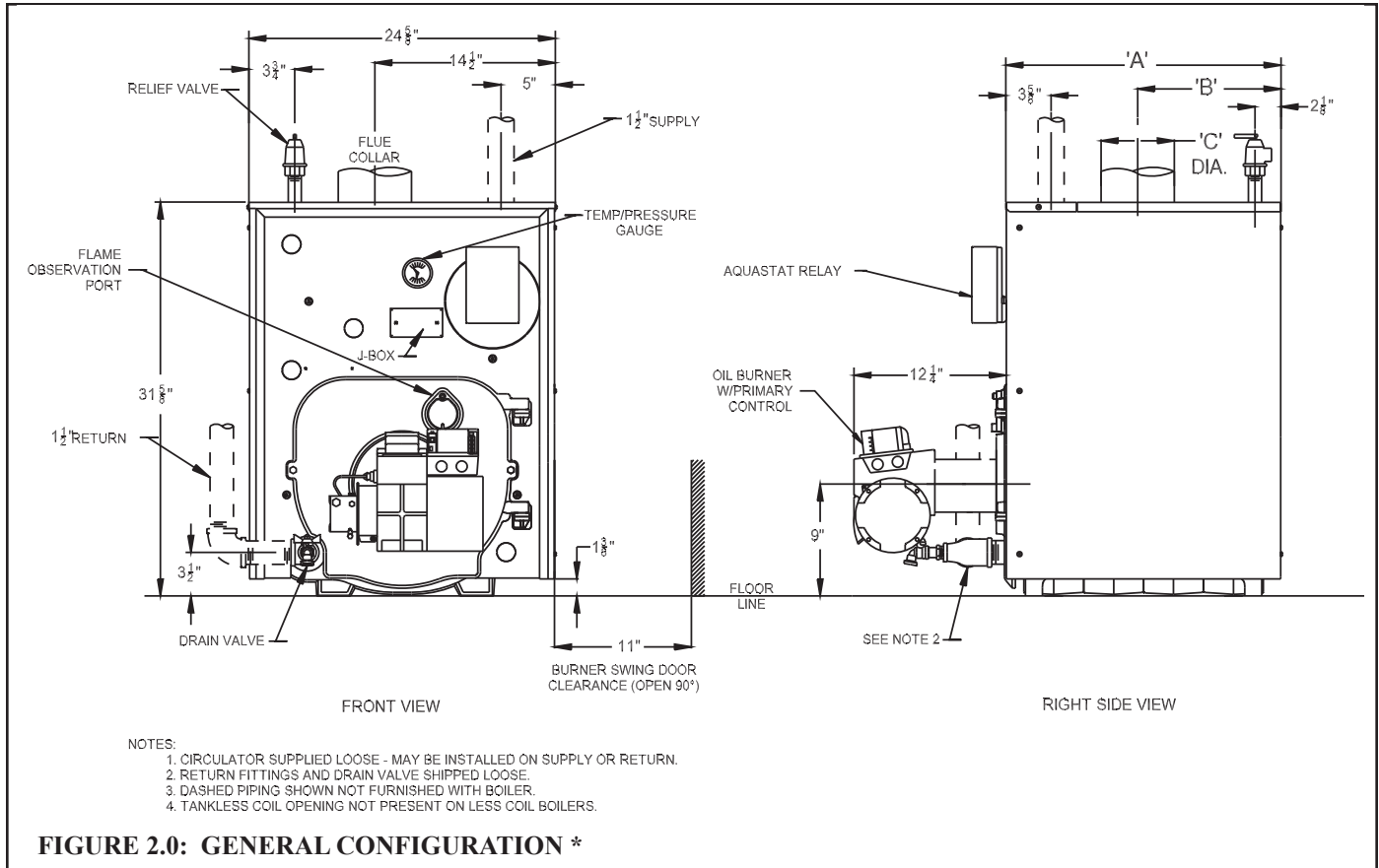

TABLE 2.1: GENERAL SPECIFICATIONS

Boiler Model	Number of Sections	Burner Input (Gal/hr)	DOE Heating Capacity (Btu/hr)	I=B=R Net Rating (Btu/hr)	AFUE (%)	Approx. Water Content (Gal)	Dimensions (inches)		
							"A"	"B"	"C"
TWZ065	3	0.65	80000	70000	86.1	16.0	17-3/8	8 5/16	6
TWZ075	3	0.75	91000	79000	85.8	16.0	17-3/8	8 5/16	6
TWZ100	3	1.00	120000	104000	84.3	16.0	17-3/8	8 5/16	6
TWZ090	4	0.90	111000	97000	86.0	20.0	22-3/8	10 13/16	7
TWZ125	4	1.25	152000	132000	85.1	20.0	22-3/8	10 13/16	7
TWZ150	4	1.50	179000	156000	84.0	20.0	22-3/8	10 13/16	7
TWZ120	5	1.20	147000	128000	86.0	24.0	27-3/8	13 5/16	8
TWZ175	5	1.75	212000	184000	85.1	24.0	27-3/8	13 5/16	8
TWZ200	5	2.00	241000	210000	84.7	24.0	27-3/8	13 5/16	8

TABLE 2.2: OPTIONAL TANKLESS HEATER RATINGS

Boiler Model	Tankless Heater Rating (Gal/min)
TWZ065	2.75
TWZ075	3.00
TWZ100	3.25
TWZ090	3.25
TWZ125	3.75
TWZ150	4.00
TWZ120	3.50
TWZ175	4.25
TWZ200	4.75

Notes:

1. Net Ratings are based on piping and pick-up allowances of 1.15.
2. Burner Capacity Rating, GPH is based on #2 oil with a Gross Heating Value equal to 140000 BTU/Gal.
3. Maximum Working Pressure, Water - 50 PSI.
4. Tankless Heater Ratings based on I=W=H test standard.

III Before Installing

1) Safe, reliable operation of this boiler depends upon installation by a professional heating contractor in strict accordance with this manual and the requirements of the authority having jurisdiction.

- In the absence of an authority having jurisdiction, installation must be in accordance with this manual and the latest edition of *Installation of Oil Burning Equipment* (ANSI/NFPA31).
- Where required by the authority having jurisdiction, this installation must conform to the latest edition of *Standard for Controls and Safety Devices for Automatically Fired Boilers* (ANSI/ASME CSD-1).

2) Make sure that a properly sized chimney is available which is in good condition. Consult the authority having jurisdiction, Part VI of this manual, and ANSI/NFPA31 for additional information on venting requirements.

Power (“Side Wall”) Venting - Important Note

Two problems arise when any oil-fired appliance is power vented:

1. There is sometimes an accelerated rate of soot buildup on the oil burner cad-cell, spinner etc.
2. There is a potential for severe damage to the side of the structure in the event that the boiler operates at a high smoke level. This can happen for many reasons, some of which are out of the control of both the installer and appliance manufacturer.

Crown Boiler Company recommends the use of a chimney to vent the TWZ series boilers. If a power venter must be used, it is the responsibility of the installer and power vent manufacturer to “engineer” the power vent system. **CROWN BOILER COMPANY WILL ASSUME NO RESPONSIBILITY FOR DAMAGE TO SIDING, ETC. FROM A POWER VENTED OIL-FIRED BOILER. THIS APPLIES REGARDLESS OF THE CAUSE OF THE SOOTING.**

3) Make sure that the boiler is correctly sized:

- For heating systems employing convection radiation (baseboard or radiators) use an industry accepted sizing method such as the $I=B=R$ Guide RHH published by the Air-Conditioning, Heating and Refrigeration Institute (AHRI).
- For new radiant heating systems refer to the radiant tubing manufacturer’s boiler sizing guidelines.
- For systems including a Crown Mega-Stor indirect water heater, size the boiler to have either the Heating Capacity required for the Mega-Stor or the $I=B=R$ Net Rating required for the heating system, whichever results in the larger boiler.
- For systems that incorporate other indirect water heaters, refer to the indirect water heater manufacturer’s instructions for boiler output requirements.

4) In some cases, boilers installed at altitudes above 2000ft may require a different burner configuration from that at sea level. Consult the local Crown representative for more information.

IV Locating the Boiler



WARNING

FAILURE TO OBSERVE THE FOLLOWING LOCATION REQUIREMENTS COULD RESULT IN PROPERTY DAMAGE, A FIRE, EXPLOSION OR CARBON MONOXIDE (CO) HAZARD.

1) Clearances:

- Observe the minimum clearances shown below. Except as noted, these clearances apply to all combustible construction, as well as noncombustible walls, ceilings and doors. Also see Figure 4.0.

Front – 24”

Left Side – 6”

Right Side – 6”

Rear – 6”

Top – 6”

Single Wall Chimney Connector (to combustible construction) - 18”

- A 24” service clearance from the jacket is recommended from the top of the boiler. This clearance may be reduced to that shown above; however, servicing the boiler will become increasingly difficult as this clearance is reduced.

2) If listed Type L vent is used, follow vent pipe manufacturer recommendations for minimum clearances.

3) Do not install this boiler directly on a combustible surface. Where it is desired to install the TWZ over a non-carpeted combustible surface, install the boiler on the base shown in Figure 4.1.

4) Do not install this boiler in a location where gasoline or other flammable vapors or liquids will be stored or used. Do not install this boiler in an area where large amounts of airborne dust will be present, such as a workshop.

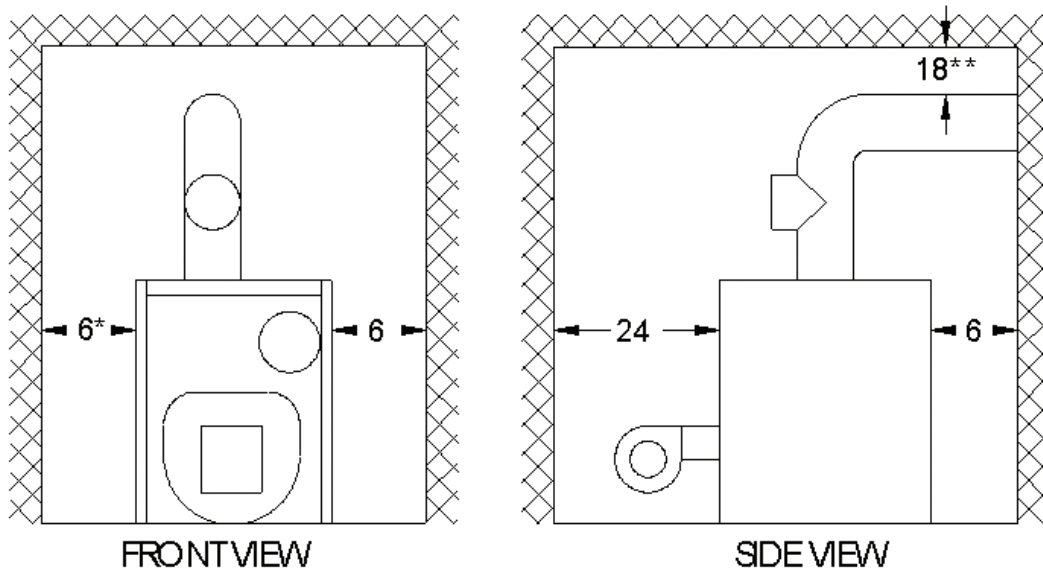

* LH SIDE CLEARANCE 24" FOR FLOAT TYPE LWC O EQUIPPED BOILERS

** CLEARANCE FROM SINGLE WALL CONNECTOR TO COMBUSTIBLE CONSTRUCTION

FIGURE 4.0: CLEARANCES

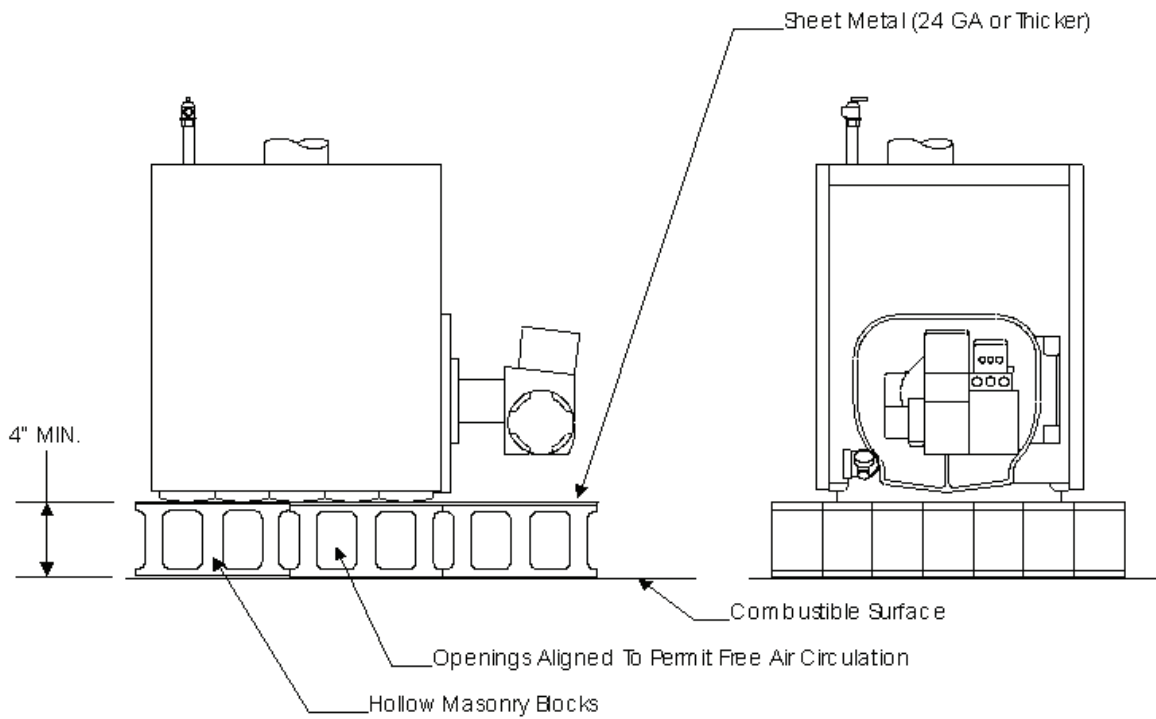

FIGURE 4.1: INSTALLATION OVER A COMBUSTIBLE FLOOR

V Air for Combustion and Ventilation



WARNING

- INSUFFICIENT COMBUSTION AIR SUPPLY MAY RESULT IN THE PRODUCTION AND RELEASE OF SOOT OR DEADLY CARBON MONOXIDE (CO) INTO THE HOME WHICH CAN CAUSE PROPERTY DAMAGE, SEVERE PERSONAL INJURY OR DEATH.
- THIS BOILER IS NOT DESIGNED FOR USE IN A SPACE THAT IS DEPRESSURIZED RELATIVE TO THE OUTDOORS. OPERATING THIS BOILER IN A DEPRESSURIZED SPACE MAY CAUSE PROPERTY DAMAGE, SEVERE PERSONAL INJURY OR DEATH.

Sufficient fresh air must be supplied for combustion and ventilation. Provisions for combustion and ventilation air for oil burning equipment must be made in accordance with Section 1.5, Air for Combustion and Ventilation, in the latest edition of *Installation of Oil Burning Equipment* (ANSI/NFPA 31).

To ensure an adequate supply of air for combustion, ventilation and flue gas dilution, start by determining whether the boiler is to be installed in a building of unusually tight construction. A building of unusually tight construction can be defined as one having the following features:

- Walls and ceilings exposed to outside atmosphere have a continuous water vapor retarder with a rating of 1 perm or less with openings gasketed and sealed
- Weather stripping has been added on openable windows and doors
- Caulking and sealants are applied to areas such as joints around window and door frames, between sole plates and floors, between wall-ceiling joints, between wall panels, at penetrations for plumbing, electrical, and gas lines, and at other openings.

For Buildings of Other than Unusually Tight Construction

1) Determine whether the boiler is to be installed in a confined space - A confined space is defined as having a volume less than 50 cubic feet per 1000 BTU/hr input of all appliances installed in that space. To determine whether the boiler room is a confined space:

a. Total the input of all appliances in the boiler room in thousands of BTU/hr. Round the result to the next highest 1000 BTU/hr.

b. Find the volume of the room in cubic feet. The volume of the room in cubic feet is:

Length (ft) x width (ft) x ceiling height (ft)

In calculating the volume of the boiler room, consider the volume of adjoining spaces only if no doors are installed between them. If doors are installed between the boiler room and an adjoining space, do not consider the volume of the adjoining space, even if the door is normally left open.

c. Divide the volume of the boiler room by the input in thousands of BTU/hr. If the result is less than 50, the boiler room is a confined space.

Example:

A TWZ090 and a water heater are to be installed in a room measuring 6 ft - 3 in x 7 ft with an 8 ft ceiling. The water heater has an input of 30000 BTU/hr:

Input of TWZ090 = 0.90 Gal/hr x 140000 BTU/Gal = 126000 BTU/hr

Total input in thousands of BTU/hr = (126000 BTU/hr + 30000 BTU/hr)/1000 = 156

Volume of room = 6.25 ft x 7 ft x 8 ft = 350 ft³

350/156 = 2.24. Since 2.24 is less than 50, the boiler room is a confined space.

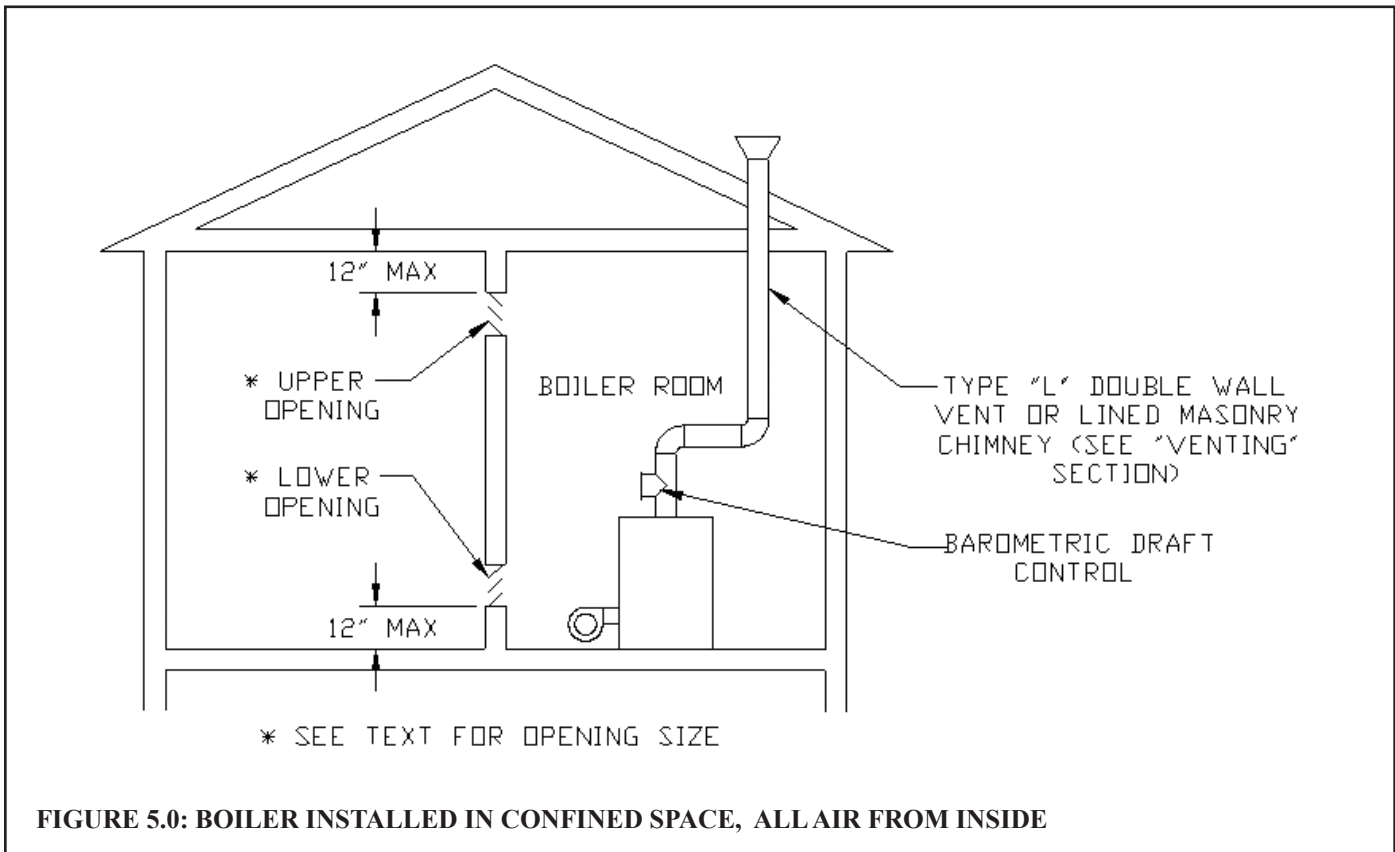

FIGURE 5.0: BOILER INSTALLED IN CONFINED SPACE, ALL AIR FROM INSIDE

- 2) Unconfined Space - Natural infiltration into the boiler room will normally provide adequate air for combustion and ventilation without additional louvers or openings into boiler room.
- 3) Confined Space - Provide two openings into the boiler room, one near the floor and one near the ceiling. The top edge of the upper opening must be within 12" of the ceiling and the bottom edge of the lower opening must be within 12" of the floor (Figure 5.0).
 - Each opening must have a free area of 1 square inch per 1000 BTU/hr input of all fuel burning appliances in the boiler room. The minimum opening dimension is 3 inches. Minimum opening free area is 100 square inches per opening.
 - If the total volume of both the boiler room and the room to which the openings connect is less than 50 cubic feet per 1000 BTU/hr of total appliance input, install a pair of identical openings into a third room. Connect additional rooms with openings until the total volume of all rooms is at least 50 cubic feet per 1000 BTU/hr of input.
 - The "free area" of an opening takes into account the blocking effect of mesh, grills, and louvers. Where screens are used, they must be no finer than 1/4" (4 x 4) mesh.

For Buildings of Unusually Tight Construction:

- 1) Openings must be installed between the boiler room and the outdoors or a ventilated space, such as an attic or crawl space, which communicates directly with the outdoors.
- 2) Two openings are required. The top edge of the upper opening must be within 12 inches of the ceiling. The bottom edge of the lower opening must be within 12 inches of the floor.
- 3) Size openings and ducts as follows:
 - Vertical ducts or openings directly outdoors (Figure 5.1, Figure 5.2, and Figure 5.3) - Each opening must have a free cross sectional area of 1 square inch per 4000 BTU/hr of the total input of all fuel fired appliances in the boiler room but not less than 100 square inches. Minimum opening size is 3 inches.
 - Openings to outdoors via horizontal ducts (Figure 5.4) - Each opening must have a free cross sectional area of 1 square inch per 2000 BTU/hr of the total input of all fuel fired appliances in the boiler room but not less than 100 square inches. Minimum opening size is 3 inches.
 - The "free area" of an opening takes into account the blocking effect of mesh, grills, and louvers. Where screens are used, they must be no finer than 1/4" (4 x 4) mesh.

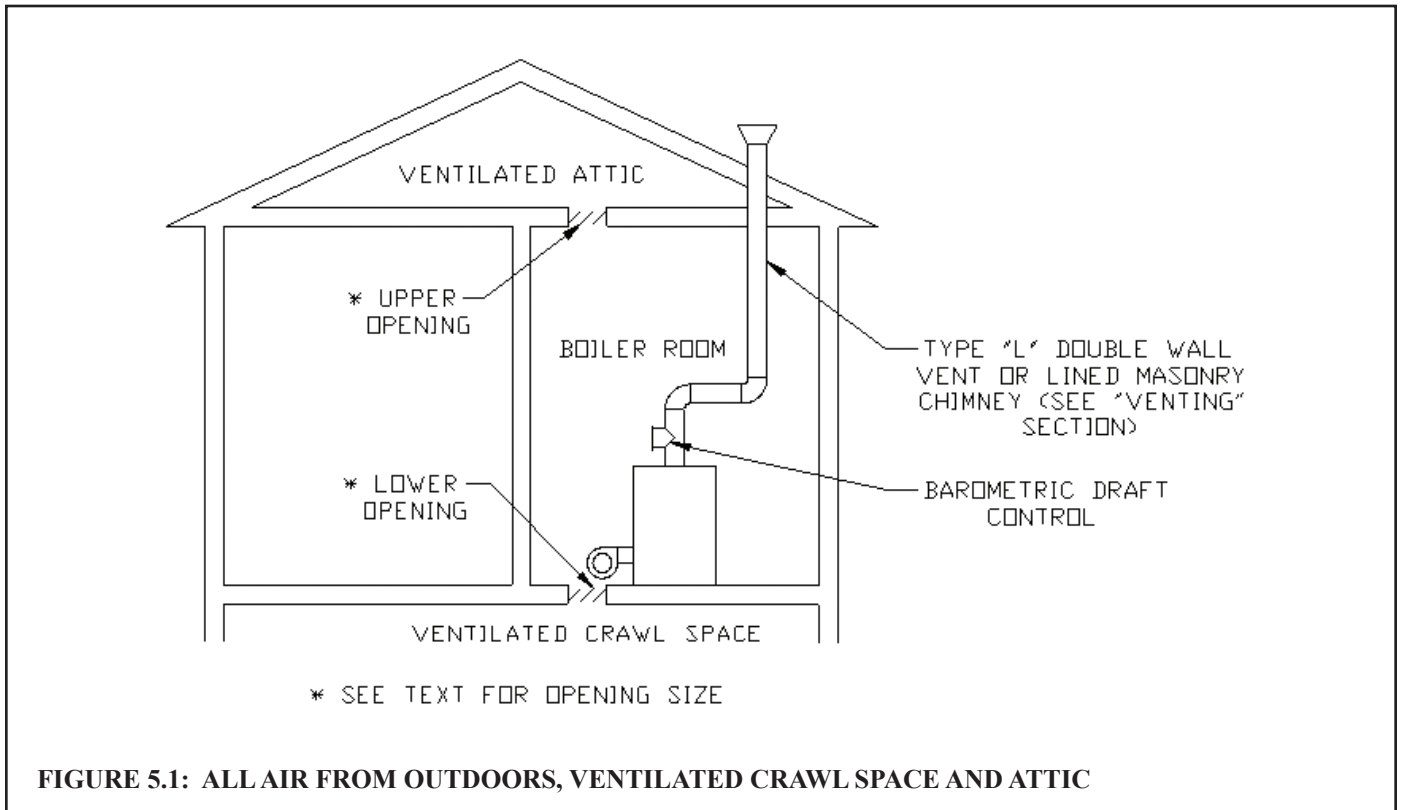

FIGURE 5.1: ALL AIR FROM OUTDOORS, VENTILATED CRAWL SPACE AND ATTIC

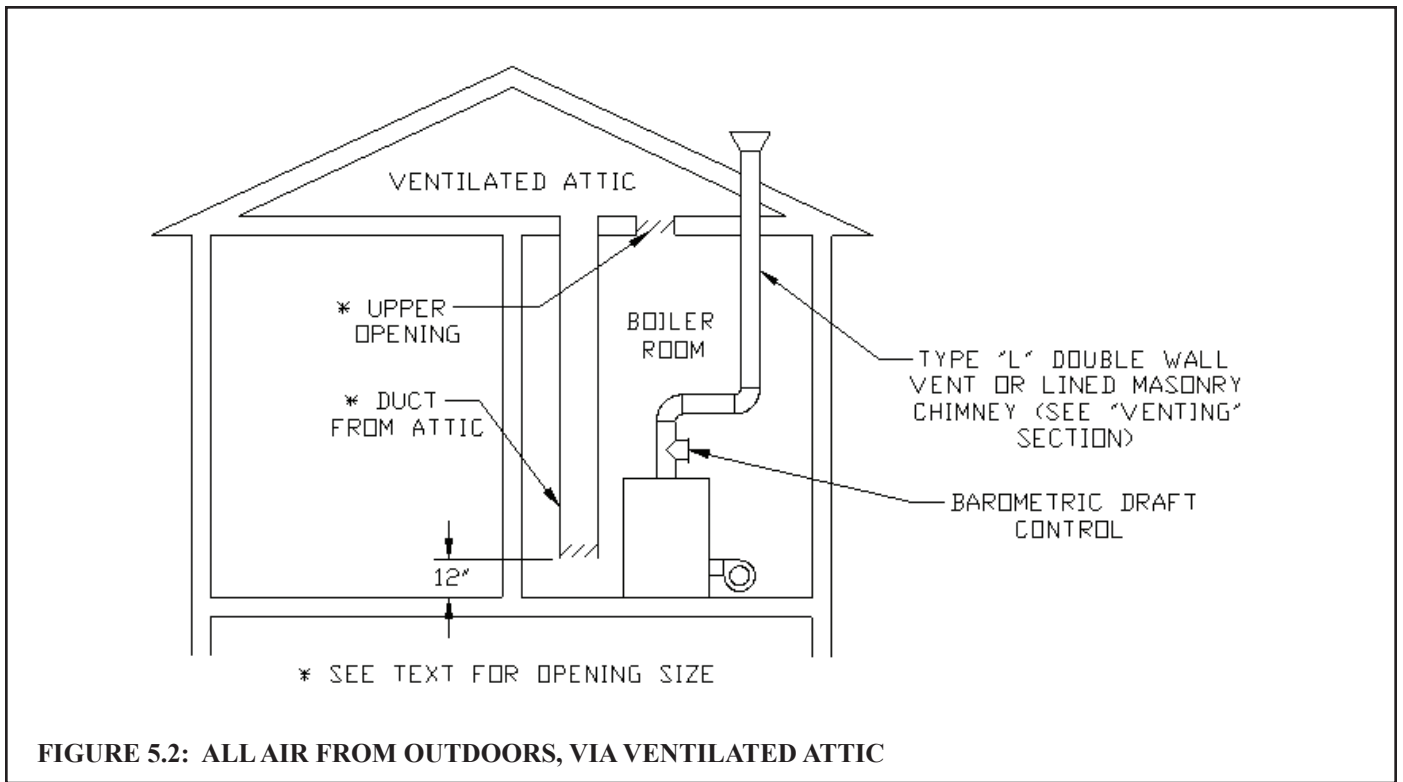

FIGURE 5.2: ALL AIR FROM OUTDOORS, VIA VENTILATED ATTIC

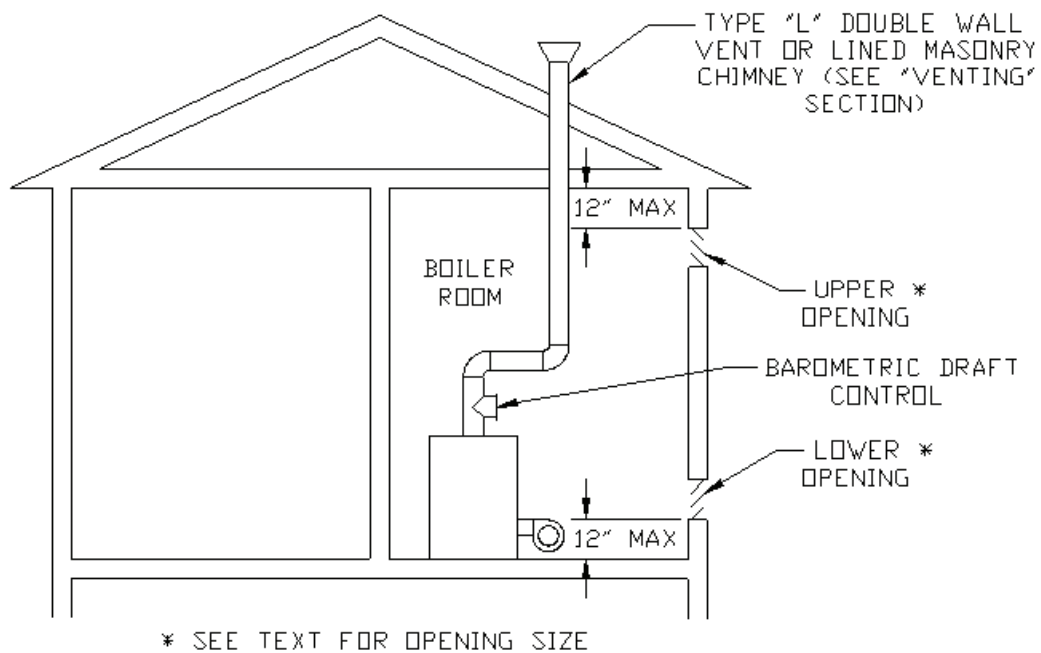

FIGURE 5.3: ALL AIR FROM OUTDOORS, USING OPENINGS INTO BOILER ROOM

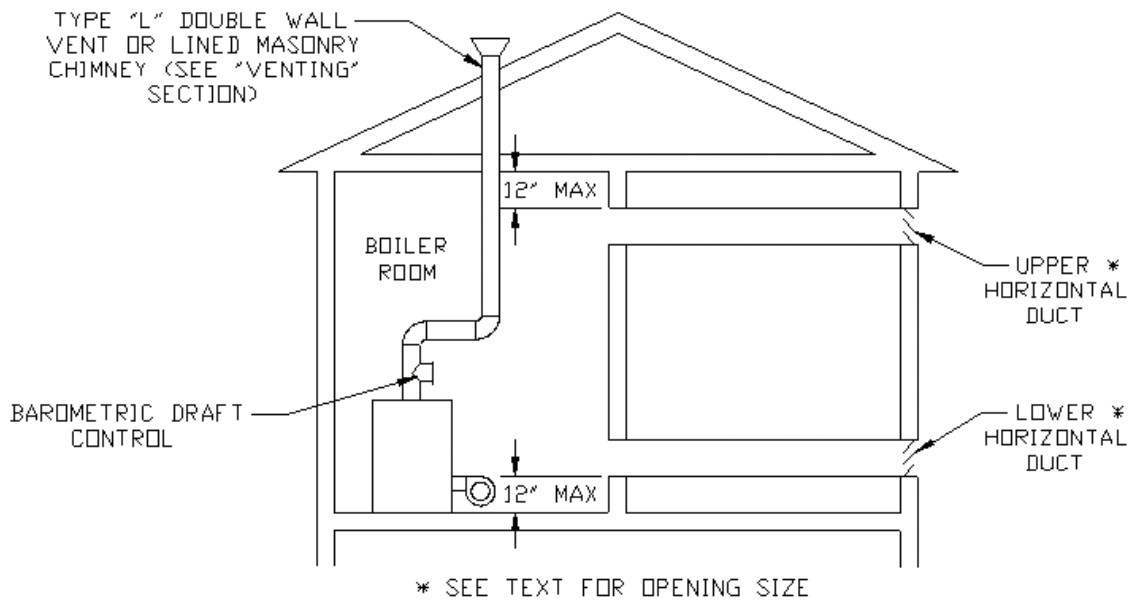

FIGURE 5.4: ALL AIR FROM OUTDOORS, USING HORIZONTAL DUCTS INTO BOILER ROOM

VI Venting



WARNING

- IMPROPER VENTING MAY RESULT IN PROPERTY DAMAGE AND/OR THE RELEASE OF FLUE GASES, WHICH CONTAIN DEADLY CARBON MONOXIDE (CO), INTO THE HOME, WHICH CAN CAUSE SEVERE PERSONAL INJURY OR DEATH.
- INSPECT EXISTING CHIMNEY BEFORE INSTALLING BOILER. FAILURE TO CLEAN OR REPLACE DAMAGED PIPE OR TILE LINING WILL CAUSE PROPERTY DAMAGE, SEVERE PERSONAL INJURY OR DEATH.

Vent installation must be in accordance with local building codes, or the local authority having jurisdiction.

Typical vent installation is illustrated by Figure 6.0. The components of vent installation are the vent connector (breeching), barometric draft regulator, and chimney.

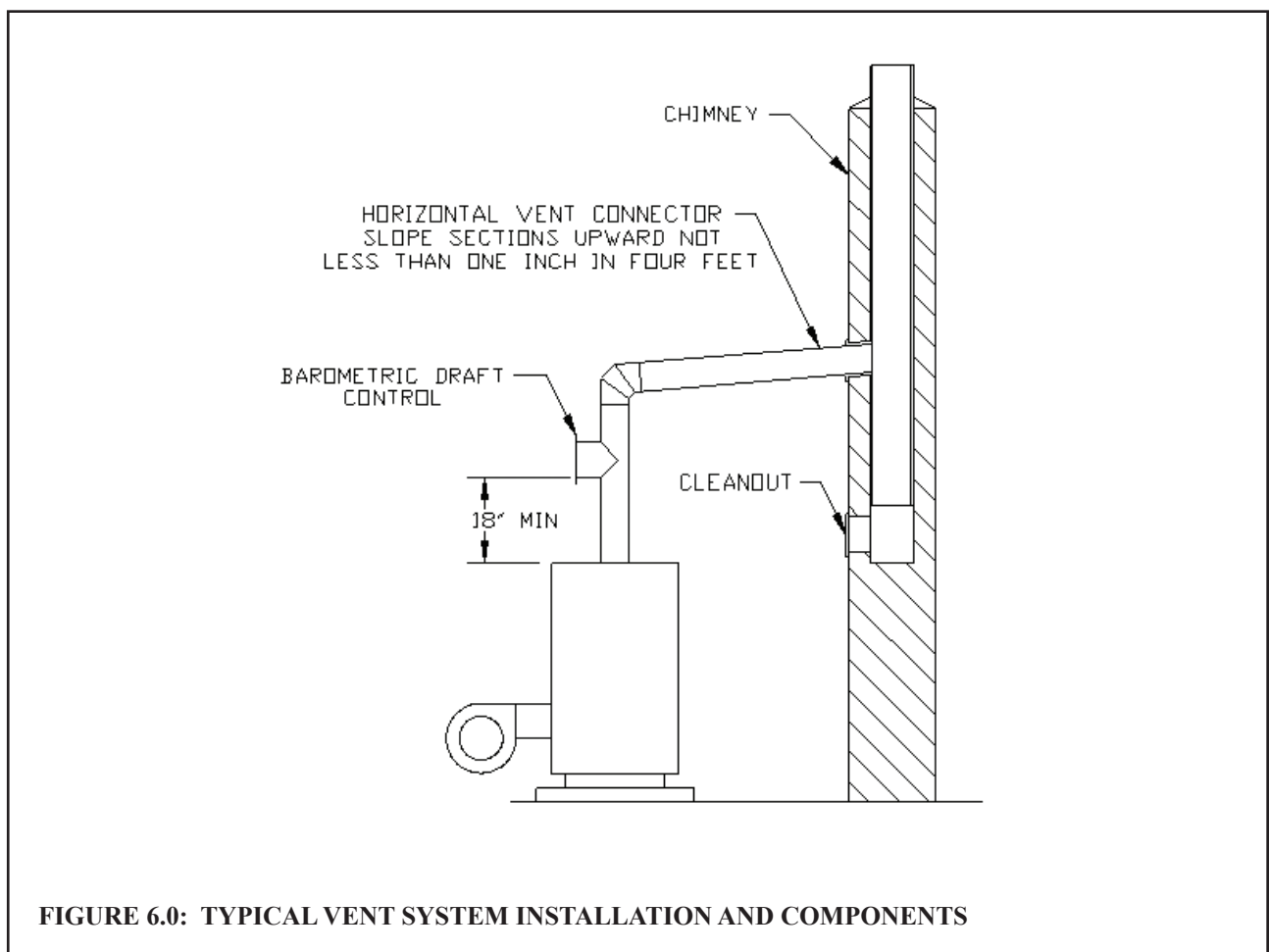

1) Acceptable Chimneys - The following chimneys may be used to vent a TWZ series boiler:

- Listed Type L vent - Install in accordance with the manufacturer's instructions, the terms of its listing, and applicable codes.
- Masonry Chimney - The masonry chimney must be constructed in accordance with the latest edition of *Standard for Chimneys, Fireplaces, Vents, and Solid Fuel Burning Appliances* (NFPA 211) and lined with a clay liner or other listed lining system. Do not vent a TWZ series boiler into an unlined chimney.

- 2) Acceptable Vent Connectors - The following may be used for vent connectors:
- Listed Type L vent.
 - Single Wall Galvanized Pipe - Use 0.018" (26 gauge) or heavier.
- 3) Chimney and Vent Connector Sizing - See Table 6.1 for minimum vent connector and chimney sizing. The vent connector size must not be smaller than boiler flue collar diameter.
- 4) Do not vent this appliance into any portion of a mechanical vent system operating under positive pressure.
- 5) Do not connect the boiler into a chimney flue serving an open fireplace or other solid fuel appliance.
- 6) Prior to boiler installation, inspect chimney for obstructions or other defects and correct as required. Clean chimney as necessary.
- 7) Vent pipe should slope upward from boiler not less than one inch in four feet. No portion of vent pipe should run downward or have sags. Vent pipe must be securely supported.
- 8) The vertical section of vent pipe coming off the boiler should be as tall as possible, while still maintaining the proper clearance from the horizontal vent connector to combustibles and the proper pitch called for in (7) above.
- 9) Vent pipe should be installed above the bottom of the chimney to prevent blockage.
- 10) Vent pipe must be inserted flush with inside face of the chimney liner and the space between vent pipe and chimney sealed tight. A thimble permanently cemented in place can be used to facilitate removal of chimney connector for cleaning.
- 11) Install the barometric draft regulator in accordance with the regulator manufacturer's instructions.
- 12) Secure all joints in the vent connector system with sheet metal screws. This includes the joint between the vent connector and the boiler collar, as well as the barometric draft regulator. Use at least three screws at each joint.

TABLE 6.1: MINIMUM RECOMMENDED BREECHING AND CHIMNEY SIZE

Boiler Model	Min Breeching Dia. (inches)	Min. Recommended Chimney Size and Height		
		Round I.D. (in)	Rectangular I.D. (in)	Height (ft)
TWZ065	6	6	8 x 8	15
TWZ075	6	6	8 x 8	15
TWZ100	6	6	8 x 8	15
TWZ090	7	7	8 x 8	15
TWZ125	7	7	8 x 8	15
TWZ150	7	7	8 x 8	15
TWZ120	8	8	8 x 8	15
TWZ175	8	8	8 x 8	15
TWZ200	8	8	8 x 8	15

Power ("Side Wall") Venting - Important Note

Two problems arise when any oil-fired appliance is power vented:

1. There is sometimes an accelerated rate of soot buildup on the oil burner cad-cell, spinner etc.
2. There is a potential for severe damage to the side of the structure in the event that the boiler operates at a high smoke level. This can happen for many reasons, some of which are out of the control of both the installer and appliance manufacturer.

Crown Boiler Company recommends the use of a chimney to vent the TWZ series boilers. If a power venter must be used, it is the responsibility of the installer and power vent manufacturer to "engineer" the power vent system. **CROWN BOILER COMPANY WILL ASSUME NO RESPONSIBILITY FOR DAMAGE TO SIDING, ETC. FROM A POWER VENTED OIL-FIRED BOILER. THIS APPLIES REGARDLESS OF THE CAUSE OF THE SOOTING.**

VII System Piping



WARNING

- INSTALL BOILER SO THAT THE ELECTRICAL COMPONENTS ARE PROTECTED FROM WATER (DRIPPING, SPRAYING, RAIN, ETC.) DURING APPLIANCE OPERATION AND SERVICE (CIRCULATOR REPLACEMENT, ETC.).
- OPERATION OF THIS BOILER WITH CONTINUOUS RETURN TEMPERATURES BELOW 120°F CAN CAUSE SEVERE HEAT EXCHANGER CORROSION DAMAGE.
- OPERATION OF THIS BOILER IN A SYSTEM HAVING SIGNIFICANT AMOUNTS OF DISSOLVED OXYGEN CAN CAUSE SEVERE HEAT EXCHANGER CORROSION DAMAGE.
- DO NOT USE TOXIC ADDITIVES, SUCH AS AUTOMOTIVE ANTIFREEZE, IN A HYDRONIC SYSTEM.
- PIPE RELIEF VALVE DISCHARGE TO A SAFE LOCATION. THE RELIEF VALVE MAY DISCHARGE SCALDING HOT WATER.
- DO NOT INSTALL A VALVE IN THE RELIEF VALVE DISCHARGE LINE.
- DO NOT MOVE RELIEF VALVE FROM FACTORY LOCATION.
- DO NOT PLUG RELIEF VALVE DISCHARGE. BLOCKING THE RELIEF VALVE MAY RESULT IN BOILER EXPLOSION.

Standard Piping

Figure 7.1 shows typical boiler system connections on a single zone system. Additional information on hydronic system design may be found in the *I=B=R* Guide RHH published by the Air-Conditioning, Heating and Refrigeration Institute (AHRI). The components in this system and their purposes are as follows:

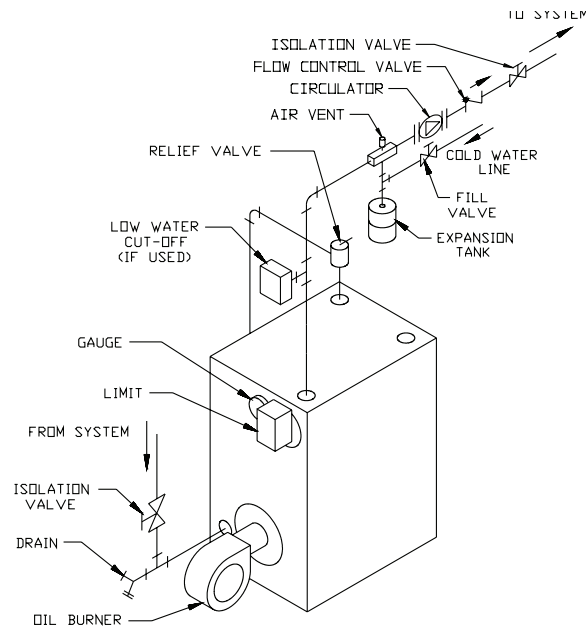

FIGURE 7.1: STANDARD BOILER PIPING

- 1) Relief valve (Required) - Mount the relief valve on the top left side of the boiler as shown in Figure 7.1 using the 3/4” nipple provided. The relief valve shipped with the boiler is set to open at 30 psi. This valve may be replaced with one having a pressure up to the “Maximum Allowable Working Pressure” shown on the rating plate. If the valve is replaced, the replacement must have a relief capacity in excess of the DOE heating capacity for the boiler.
Pipe the discharge of the relief valve to a location where water or steam will not create a hazard or cause property damage if the valve opens. The end of the discharge pipe must terminate in an unthreaded pipe. If the relief valve discharge is not piped to a drain, it must terminate at least 6 inches above the floor. Do not run relief valve discharge piping through an area that is prone to freezing. The termination of the relief valve discharge piping must be in an area where it is not likely to become plugged by debris.
- 2) Circulator (Required) - Figure 7.1 shows the ideal location of the circulator which is in the supply piping immediately downstream of the expansion tank. A less ideal, but acceptable, location for most residential circulators is in the return (if this is done, be sure that adequate clearance exists to open the door.
- 3) Expansion Tank (Required) - If this boiler is replacing an existing boiler with no other changes in the system, the old expansion tank can generally be reused. If the expansion tank must be replaced, consult the expansion tank manufacturer’s literature for proper sizing.
- 4) Fill Valve (Required) - Either a manual or automatic fill valve may be used. The ideal location for the fill is at the expansion tank.
- 5) Automatic Air Vent (Required) - At least one automatic air vent is required. Manual vents will usually be required in other parts of the system to remove air during initial fill.
- 6) Low Water Cut-Off (Required in some situations) - A low water cut-off is required when the boiler is installed above radiation. In addition, some codes such as ASME CSD-1, require low water cut-offs. Codes may also require that this low water cut-off have a manual reset function. The low water cut-off may be a float type or probe type, but must be designed for use in a hot-water system. The low water cut-off should be piped into the boiler supply just above the boiler with no intervening valves between it and the boiler.
Use a low water cut-off that breaks the 120 VAC supply to the boiler. Do not attempt to wire a 24-volt low water cut-off into the boiler factory wiring.
- 7) Manual Reset High Limit (Required by some codes) - This control is required by ASME CSD-1 and some other codes. Install the high limit in the boiler supply piping just beyond the boiler with no intervening valves. Set the manual reset high limit as far above the operating limit setting as possible, but not over 240°F. Wire the control to break the 120 VAC electrical supply to the boiler.
- 8) Flow Control Valve (Required under some conditions) - The flow control valve prevents flow through the system unless the circulator is operating. A flow control valve may be necessary on converted gravity systems to prevent gravity circulation. Flow control valves are also used to prevent “ghost flows” in circulator zone systems through zones that are not calling for heat.
- 9) Isolation Valves (Optional) - Isolation valves are useful if the boiler must be drained, as they will eliminate having to drain and refill the entire system.
- 10) Drain Valve - The drain valve is shipped in the boiler parts bag. Install it in the tee on the boiler return as shown in Figure 1.

IMPORTANT

The 1 1/2” Plugged Tapping On The Bottom Rear Section Is Present For Manufacturing Purposes Only. Do Not Attempt To Use This Tapping As A Return Connection.

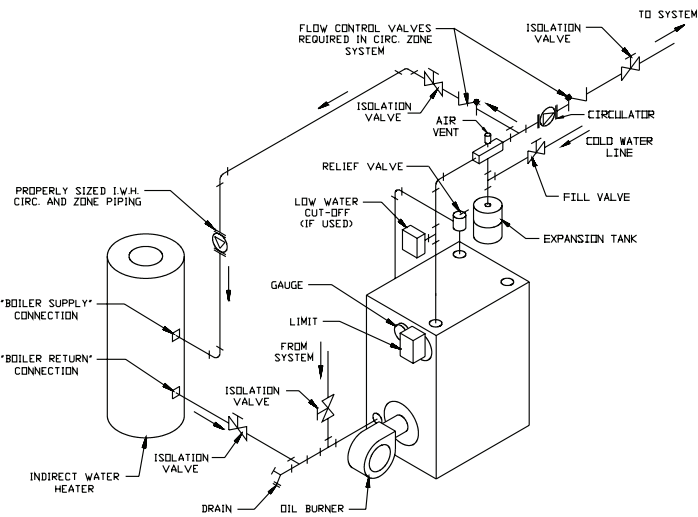

FIGURE 7.2: INDIRECT WATER HEATER BOILER SIDE PIPING

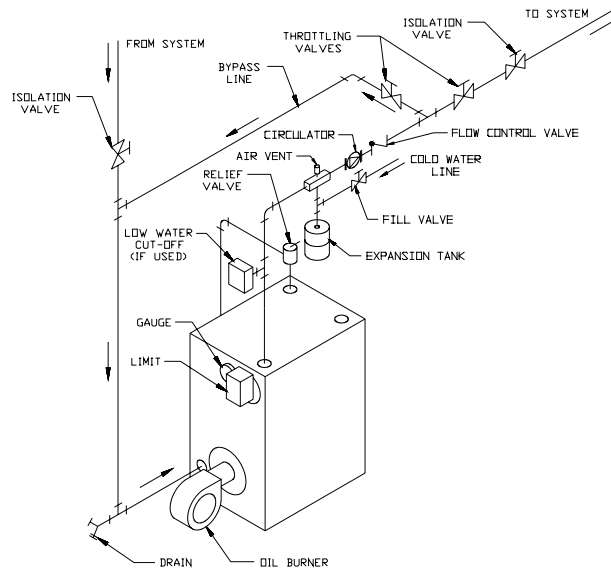

FIGURE 7.3: BOILER BYPASS PIPING

Piping for Special Situations

Certain types of heating systems have additional requirements. Some of the more common variations follow:

- 1) Indirect Water Heaters - Figure 7.2 shows typical indirect water heater piping. Boiler piping is the same as for any two-zone system. Figure 7.2 shows circulator zoning, which is usually preferred for indirect water heaters. Size the circulator and indirect water heater piping to obtain the boiler water flow through the indirect water heater called for by the indirect water heater manufacturer.
- 2) Large Water Volume Systems - The piping shown in Figure 7.3 will minimize the amount of time that the boiler operates with return temperatures below 120°F on these systems. A bypass is installed as shown to divert some supply water directly into the return water. The bypass pipe should be the same size as the supply. The two throttling valves shown are adjusted so that the return temperature rises above 120°F during the first few minutes of operation. A three-way valve can be substituted for the two throttling valves shown.

- 3) Low Temperature Systems - Some systems, such as radiant tubing systems, require the system water temperature to be limited to a value below the temperature of the water leaving the TWZ. These systems also typically have return temperatures well below the 120°F minimum.

Figure 7.4 illustrates the use of a heat exchanger to connect the TWZ boiler to this type of system. The heat exchanger will permit the transfer of heat from the boiler water to the low temperature system while holding the system supply and boiler return temperatures within their limits. For this system to work properly, the heat exchanger must be properly sized and the correct flow rates are required on either side of the heat exchanger. Consult the heat exchanger manufacturer for sizing information. The water in the boiler is completely isolated from the water in the system. This means that separate fill and expansion tanks are required for the heating system loop.

There are several other ways to connect low temperature systems to the non-condensing boilers like the TWZ such as four way mixing valves and variable speed injection pumping systems.

- 4) Systems containing oxygen - Many hydronic systems contain enough dissolved oxygen to cause severe corrosion damage to a cast iron boiler such as the TWZ. Some examples include:
- Radiant systems that employ tubing without an oxygen barrier.
 - Systems with routine additions of fresh water.
 - Systems which are open to the atmosphere.

If the boiler is to be used in such a system, it must be separated from the oxygenated water being heated with a heat exchanger as shown in Figure 7.4.

Consult the heat exchanger manufacturer for proper heat exchanger sizing as well as flow and temperature requirements. All components on the oxygenated side of the heat exchanger, such as the pump and expansion tank, must be designed for use in oxygenated water.

- 5) Air Handlers - Where the boiler is connected to air handlers through which refrigerated air passes, use flow control valves in the boiler piping or other automatic means to prevent gravity circulation during the cooling cycle.

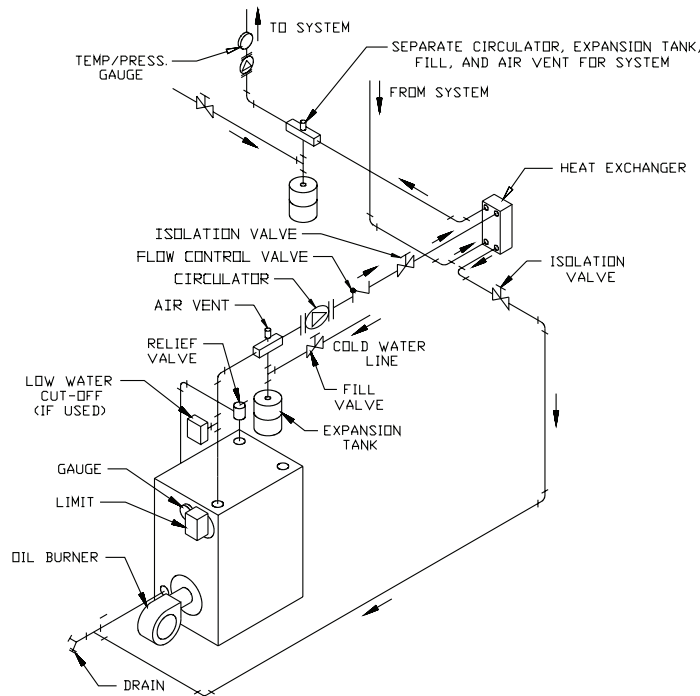

FIGURE 7.4: ISOLATION OF BOILER FROM SYSTEM WITH A HEAT EXCHANGER

VIII Tankless Heater Piping

If the TWZ is installed with an optional tankless heater, pipe the heater as shown in Figure 8.1. The components in this system and their functions are as follows:

- 1) Mixing Valve (Required) - During the heating season, the water exiting the tankless heater may be 180 degrees or more. The mixing valve blends hot water leaving the tankless heater with cold water so as to maintain the hot water supplied to the fixtures at a fixed temperature. This saves energy, increases the amount of usable hot water available to the homeowner, and reduces the risk of scalding.
Install a mixing valve with a setting range of approximately 110 to 130F. Follow the manufacturer's instructions for installing this valve. Usually a "heat trap" will be required between the coil and the "hot" connection on the mixing valve.



WARNING

A MIXING VALVE DOES NOT ELIMINATE THE RISK OF SCALDING.

- SET THE MIXING VALVE AND BOILER LOW LIMIT ADJUSTMENTS AS LOW AS POSSIBLE.
- FEEL WATER BEFORE SHOWERING OR BATHING.
- IF ANTI-SCALD OR ANTI-CHILL PROTECTION IS REQUIRED, USE DEVICES SPECIFICALLY DESIGNED FOR SUCH SERVICE. INSTALL AND MAINTAIN THESE DEVICES IN ACCORDANCE WITH THE MANUFACTURER'S INSTRUCTIONS. DO NOT USE THE MIXING VALVE AS A SUBSTITUTE FOR PRESSURE BALANCING VALVES OR OTHER DEVICES REQUIRED BY PLUMBING CODES TO PROTECT AGAINST SCALDING.

- 2) Flow Restrictor (Recommended) - If water is drawn from the tankless coil at a rate in excess of the rating in Table 2.2, the temperature of the hot water may be too low to be of use. The use of a flow restrictor will prevent this problem by limiting the rate at which water can pass through the tankless heater. If a restrictor is used, select one having a rating in GPM approximately equal to the rating shown in Table 2.2. If possible, locate this restrictor at least 3 feet from the tankless heater inlet so that it is not subjected to excessive temperatures when no water is flowing through the coil.
- 3) Pressure Relief Valve (Required) - Limits the pressure in the tankless heater and piping. Use an ASME constructed valve designed for domestic water service, such as the Watts #3L. Note that this is a pressure relief valve, not a T&P valve. Select a valve with a pressure setting less than or equal to the working pressure marked on the tankless coil. Pipe the discharge to a safe location using piping the same size as the discharge connection on the valve.
- 4) Hose Bib Valves (Recommended) - These valves permit the coil to be periodically "backflushed" to remove sediment.
- 5) Globe or Ball Valve (Recommended) - Used to adjust the flow through the entire tankless heater system if needed.
- 6) Unions (Required) - Tankless heaters may require periodic gasket replacement or other maintenance which requires removal of the heater from the boiler. Install unions anywhere in the tankless heater piping that will facilitate removal of the heater.

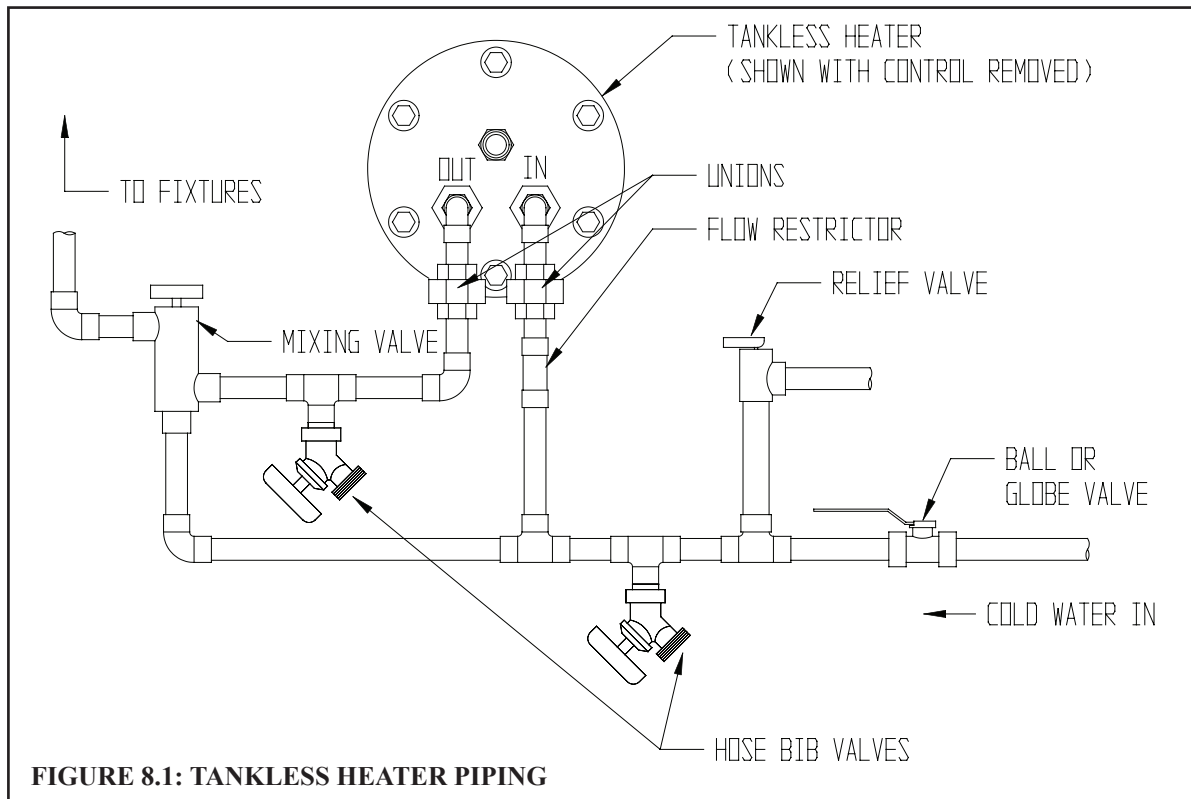

IX Fuel Line Piping



WARNING

- UNDER NO CIRCUMSTANCES CAN COPPER WITH SWEAT STYLE CONNECTORS BE USED.
- DO NOT USE COMPRESSION FITTINGS.
- OIL PIPING MUST BE ABSOLUTELY AIRTIGHT OR LEAKS OR LOSS OF PRIME MAY RESULT.
- SOME JURISDICTIONS REQUIRE THE USE OF A FUSIBLE SHUTOFF VALVE AT THE TANK AND/OR THE BURNER. IN ADDITION, SOME JURISDICTIONS REQUIRE THE USE OF A FUSIBLE ELECTRICAL INTERLOCK WITH THE BURNER CIRCUIT. CHECK YOUR LOCAL CODES FOR SPECIAL REQUIREMENTS.

Fuel line piping design, materials and construction must be in accordance with local building codes, requirements of the local authority having jurisdiction, and, the latest edition of the Standard for the Installation of Oil-Burning Equipment (ANSI/NFPA 31) in the United States and CSA B139-04 for installation in Canada. Refer also to the instruction manuals provided with the burner and oil pump.

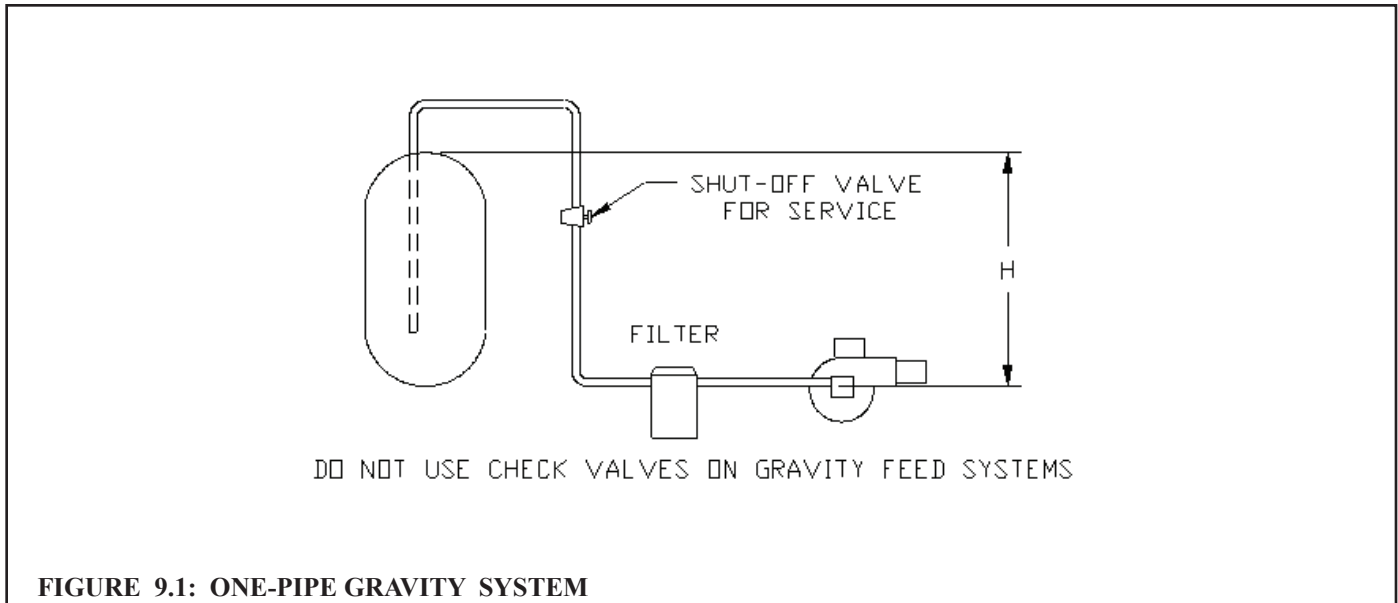

FIGURE 9.1: ONE-PIPE GRAVITY SYSTEM

Depending on the location of the fuel oil storage tank in relation to an oil burner, there are four types of oil piping systems generally being used:

- a) ONE-PIPE GRAVITY SYSTEM - used when a fuel oil storage tank is positioned above an oil burner fuel pump. See Figure 9.1. A vertical distance from top of the tank to center line of the pump (Dimension 'H') over 8 feet will result in a pump inlet pressure in excess of the 3-psi limit in NFPA-31.
- b) ONE-PIPE LIFT SYSTEM (not recommended) - Used when a fuel oil storage tank is located below an oil burner fuel pump. See Figure 9.2. The vertical distance from bottom of the tank to center line of the pump (Dimension 'H') must not exceed that shown in the pump manufacturer's instructions. Although all oil piping systems must be airtight, one-pipe lift systems are particularly susceptible to nuisance lockout problems if the suction line is not completely airtight. A two-pipe lift system is therefore recommended over a one-pipe lift system.
- c) TWO-PIPE GRAVITY SYSTEM (not recommended) - Used when a fuel oil storage tank is located above an oil burner fuel pump. See Figure 9.3. A vertical distance from top of the tank to center line of the pump (Dimension 'H') over 8 feet will result in a pump inlet pressure in excess of the 3-psi limit in NFPA-31. This type of system should be converted to a one-pipe gravity system, as doing so will result in lower inlet line flow and longer filter life.
- d) TWO-PIPE LIFT SYSTEM - used when a fuel oil storage tank is located below an oil burner fuel pump suction port. See Figure 9.4. The vertical distance from bottom of the tank to center line of the pump (Dimension 'H') must not exceed that shown in the pump manufacturer's instructions. Distance 'H' allowed is reduced by the number of fittings, filters and valves installed in the line.

Once the type of system has been selected, observe the following:

- 1) Fuel line piping must be airtight. Do not use compression type fittings for tubing connections in fuel line piping. Use only listed flare type fittings. Cast iron threaded fittings shall not be used.
- 2) Piping shall be substantially supported and protected against physical damage and corrosion where required.
- 3) Refer to supplied oil pump instruction manual for proper connections. On one-pipe systems, ensure that the fuel pump return port plug is tightened securely.
- 4) Some fuel pumps, such as the Suntec A and B series, are supplied with a loose bypass plug which must be installed on two-pipe systems. If such a plug is supplied, install it as shown in the pump manufacturer's instructions. Do not install this bypass plug on one-pipe systems as pump seal damage will result.
- 5) Do not use check valves, especially on gravity feed systems.
- 6) Do not use Teflon tape for threaded connections. Use a listed non-hardening thread sealant instead.

- 7) Attach required piping between burner fuel pump and fuel oil storage tank. Install one fuel shut-off valve near the storage tank and second fuel shut-off valve near the oil burner fuel pump. Use heavy wall copper tubing in a continuous run. On two-pipe systems, the return line should terminate 3" - 4" above suction line depth within the storage tank. Refer to the pump manufacturer's instructions for tube sizing information.
- 8) All systems require an oil filter. On TWZ065 and TWZ075 boilers, the use of a Garber cartridge type filter is recommended.
- 9) Use only #2 Fuel Oil with physical and chemical characteristics meeting the requirements of ASTM D-396.

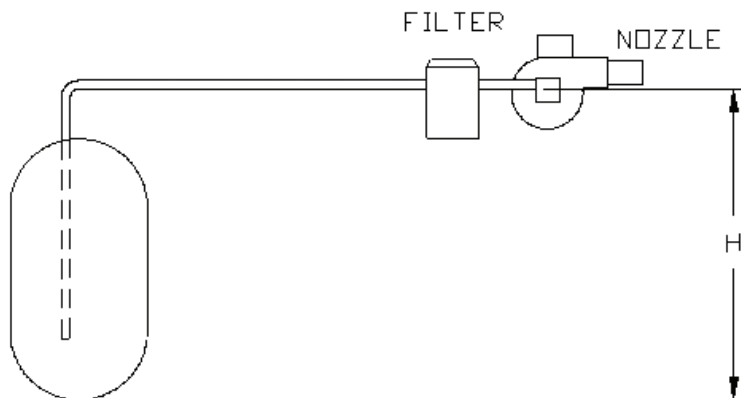

FIGURE 9.2: ONE-PIPE LIFT SYSTEM

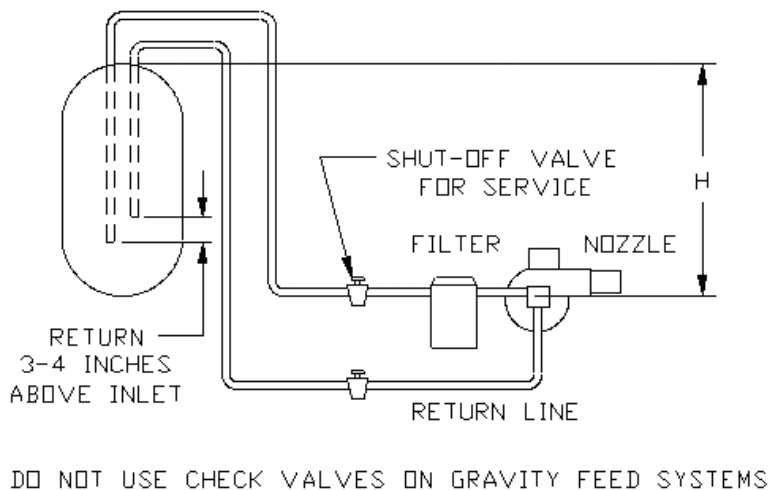

FIGURE 9.3: TWO-PIPE GRAVITY FEED SYSTEM

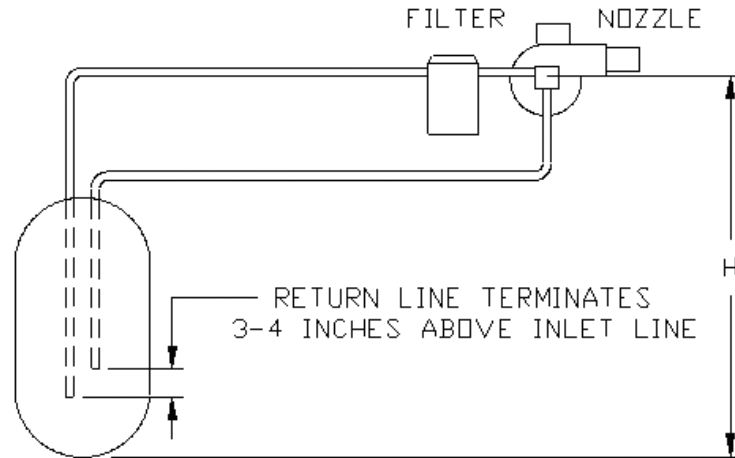

FIGURE 9.4: TWO-PIPE LIFT SYSTEM

X Wiring



WARNING

- All wiring and grounding must be done in accordance with the authority having jurisdiction or, in the absence of such requirements, with the *National Electrical Code (ANSI/NFPA 70)*.
- Disconnect electrical power to the boiler and heating system before servicing. Positively assure that no voltage is present. Lock electrical boxes to prevent someone from inadvertently restoring power before the heating system is safe to operate.
- Never defeat or jump out safety devices.
- Protect each boiler circuit with a properly sized over-current protection device.
- Make electrical connections carefully according to the boiler's wiring diagram and instructions.
- Wire additional field supplied safety limits, such as low water cutoffs and temperature limit devices, in series with the 120V circuit used to power the boiler. Do not alter the boiler's factory wiring when adding an additional limit device.

1) 120 Volt Wiring - The boiler should be provided with its own 15A branch circuit with fused disconnect. 120VAC power connections are made inside the L7248L cold start control or the L7224A warm start control as follows (also see Figures. 10.0 thru 10.2):

- Hot ("black") - Terminal "L1"
- Neutral ("white") - Terminal "L2"
- Ground ("green" or bare) - Ground screw on case of L7248L or L7224A.

The heating circulator is either factory wired to the L7248L or L7224A circulator connections or the boiler is provided with a flexible conduit “whip” that is factory wired to the L7248L or L7224A circulator connections. If the circulator is not already wired to the control, connect it as follows:

- Circulator “Hot” - Black wire lead from “whip”
- Circulator “Neutral” - White wire lead from “whip”
-

2) Low Voltage Connections – Low voltage field connections are located as shown in Figure 10.0 and 10.1 and are as follows:

- T-T - Connect to a 24 volt heating thermostat or other “dry contacts” (such as a zone panel end switch) that close upon a call for heat. Follow thermostat manufacturer’s instructions. To insure proper thermostat operation, avoid installation in areas of poor air circulation, hot spots (near any heat source or in direct sunlight), cold spots (outside walls, walls adjacent to unheated areas, locations subject to drafts). Provide Class II circuit between thermostat (or zone controls) and boiler.
- 1,2,3 - Used to connect EnviraCom thermostat, or other EnviraCOM device, approved by Crown for use with this boiler (refer to instructions provided with EnviraCOM device).

3) Adding a Second Circulator Zone - The control provided on TWZ boilers can be used to control a second heating or DHW circulator zone. If this is done, make the following 120VAC connections in addition to those described above (also see Figures 10.0 or 10.1):

- Connect a 120VAC heating or DHW thermostat for the second zone between L1 and ZR.
- Connect the DHW circulator or the second heating zone circulator between ZC and L2.

See Part XII of this manual for information on configuring the control to respond properly to the DHW or second heating zone circulator. This information differs depending on the whether the boiler is equipped with the L7248L cold start control used on boilers less tankless heater or the L7224A warm start control used on boilers with tankless heater.

4) Low Water Cut-offs - A properly installed low water cut-off (LWCO) prevents burner operation in the event that there is insufficient water in the boiler. Many jurisdictions require the installation of a LWCO, as does NFPA-31. Install the LWCO in the supply piping immediately above the boiler with no intervening valves. If a probe type LWCO is used, observe the LWCO manufacturer’s required clearances around the probe. Use a LWCO that is wired so as to interrupt 120volt power to the boiler in the event of a low water condition.

Crown 120V FWZ/TWZ LWCO Kit #411000 includes the LWCO, fittings, and wiring needed to meet the above requirements.

CAUTION

- When making low voltage connections, make sure that no external power source is present in the thermostat circuits. If such a power source is present, it could destroy the boiler’s control. One example of an external power source that could be inadvertently connected to the low voltage connections is a transformer in old thermostat wiring.
- Do not attempt to use EnviraCOM connections for any purpose not explicitly permitted by Crown Boiler Company. Attempting to do so may result in unreliable operation and/or damage to controls.
- Do not use the transformer provided on the boiler to power external devices such as zone valves. Doing so may cause damage to the transformer.

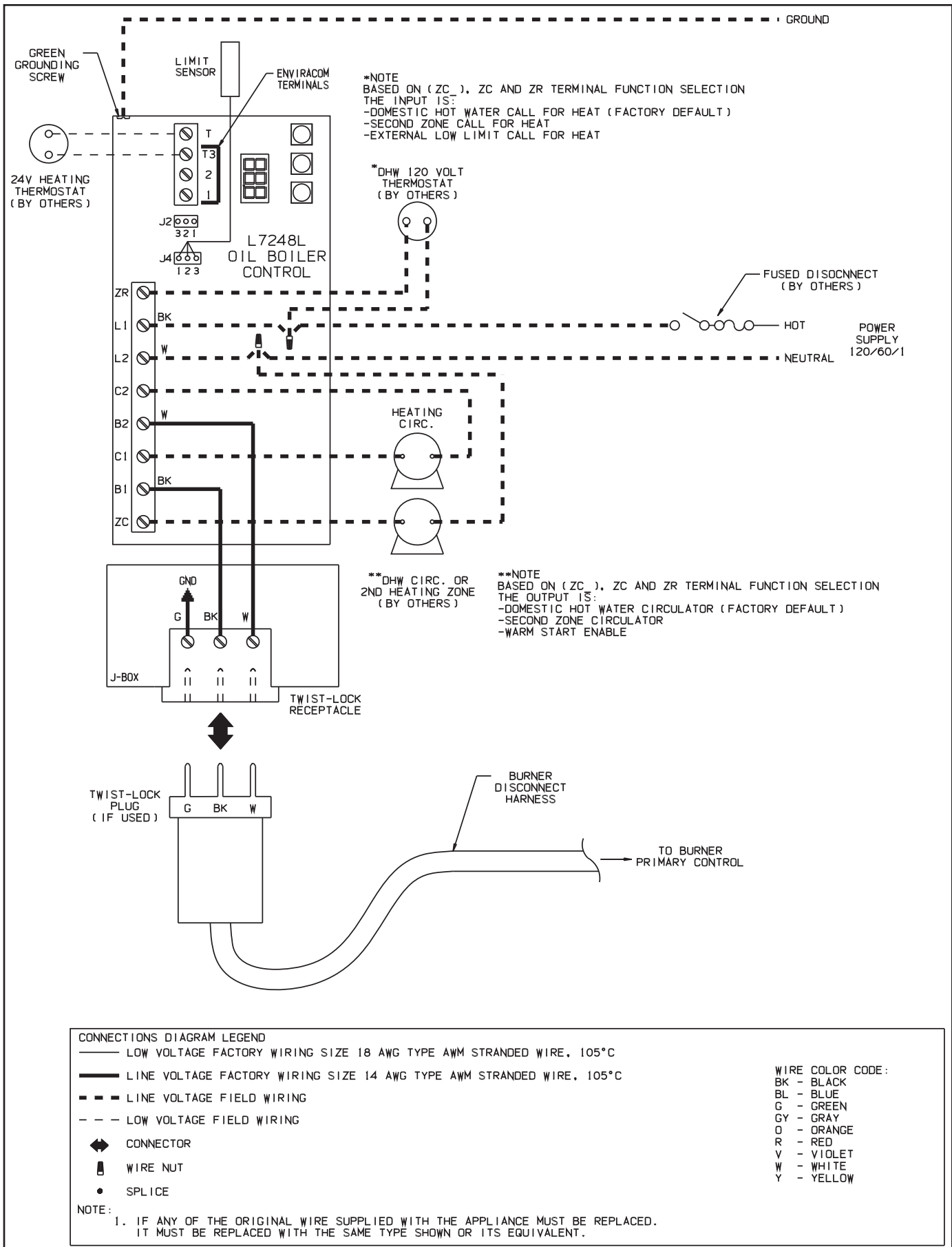

FIGURE 10.0: CONNECTIONS DIAGRAM, BOILERS LESS TANKLESS HEATER, COLD START CONTROL

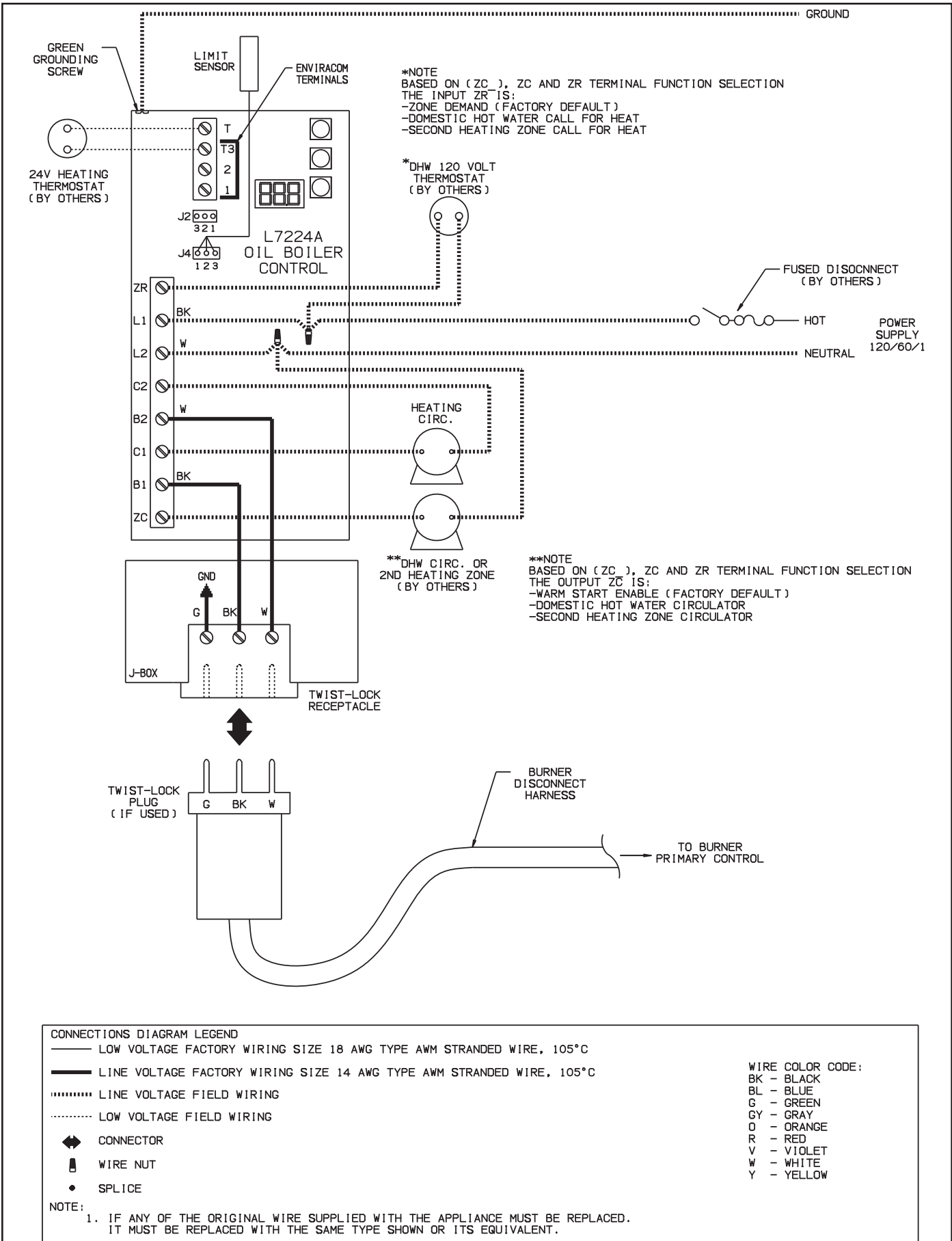
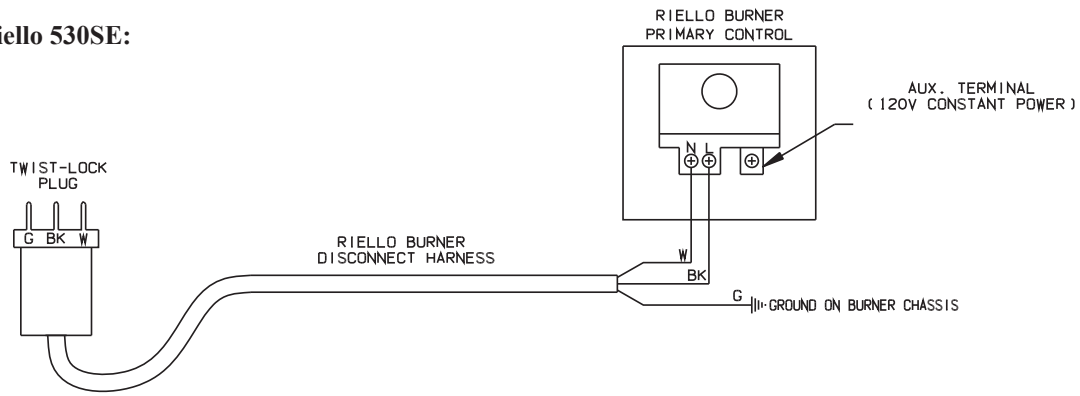
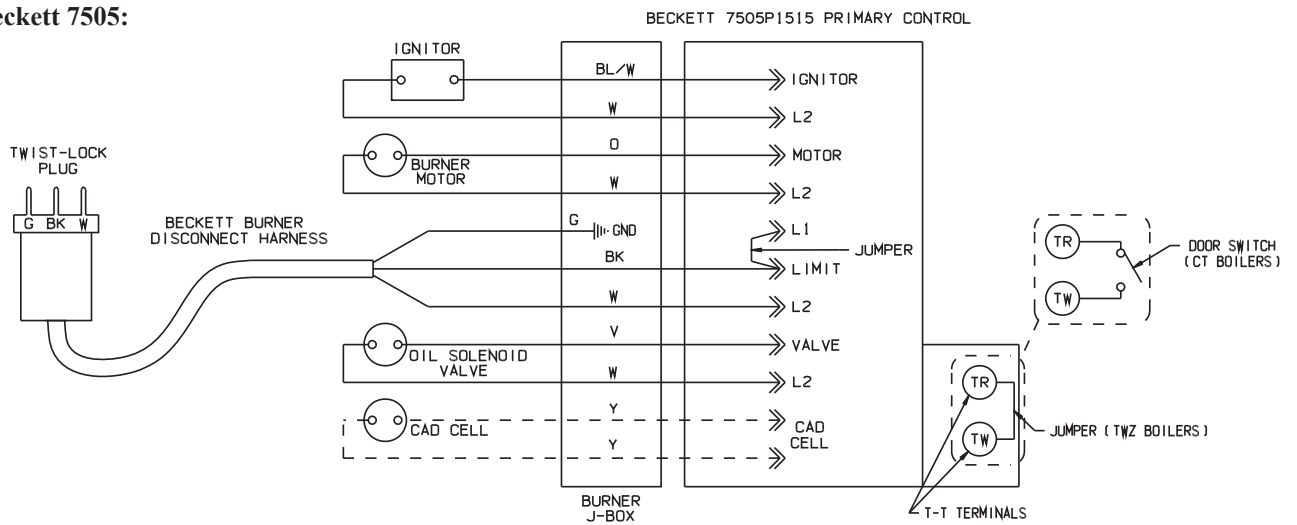

FIGURE 10.1: CONNECTIONS DIAGRAM, BOILERS WITH TANKLESS HEATER, WARM START CONTROL

Riello 530SE:



Beckett 7505:



Carlin 40200:

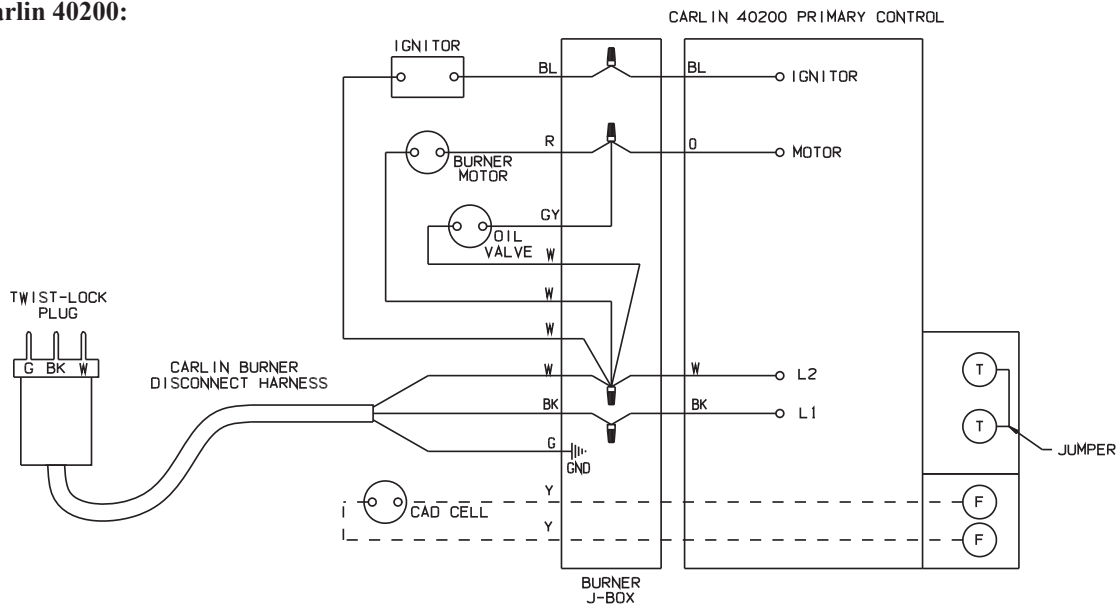

FIGURE 10.2: CONNECTIONS DIAGRAM FOR BURNER PRIMARY CONTROLS

XI Start-up and Checkout

Use the following procedure for initial start-up of the boiler:

WARNING

- Never attempt to fill a hot empty boiler.
- Make sure that the area around the boiler is clear and free from combustible materials, gasoline, and other flammable vapors and liquids.
- Safe reliable operation of this boiler requires that the burner be checked and adjusted by a qualified oil serviceman using combustion test instruments.
- Failure to perform all of the checks outlined in the following procedure could result in unreliable operation, damage to the boiler not covered under warranty, property damage, or unsafe operation.
- All boilers equipped with burner swing door have a potential hazard which can cause severe property damage, personal injury or loss of life if ignored. Before opening swing door, turn off service switch to boiler to prevent accidental firing of burner outside the combustion chamber. Be sure to tighten swing door fastener completely when service is completed. In addition, the burner power cord will have to be disconnected from the receptacle in the front jacket.

- 1) Ensure that the boiler and entire heating system are filled with water.
- 2) Check all new piping for leaks and purge heating system piping sections that are air bound.
- 3) Verify that the vent system is complete and free of obstructions prior to start-up of the boiler.
- 4) Inspect all wiring for loose or uninsulated connections, proper size fuses installed, etc.
- 5) Verify that oil tank is filled with #2 fuel oil meeting ASTM D396 specifications, oil piping has been tested and is air tight, and shutoff valve(s) are closed.
- 6) Check initial settings of oil burner air band and air shutter, head setting etc., and readjust if needed. See Table 11.0 for setup and combustion data pertaining to a particular boiler/ burner combination.
- 7) Attach plastic hose to oil pump vent fitting and provide a container to catch oil during oil pump bleeding procedure.
- 8) Install 0-200 PSI pressure gauge into oil pump gauge port.
- 9) Open all oil line shutoff valves.
- 10) Open flame observation port cover on burner swing door to see flame.
- 11) Adjust system thermostat to highest setting.
- 12) Set boiler controls (high limit, low limit, etc.) to suit individual requirements of the installation.
- 13) Turn the line service switch to "ON" position.
- 14) Crack open vent fitting on the oil pump and allow burner to run until a solid oil stream, free of air bubbles, flows for 15 seconds into container. As the vent fitting is closed, the burner should fire and flame should be visible through observation port immediately (or after prepurge timing has expired, if a burner is so equipped). Refer to burner instructions for more details.
- 15) Immediately upon firing the boiler, check the smoke level. If the smoke level is in excess of a #1, open the air adjustment to bring the smoke level below a #1.
- 16) Make sure that the oil pressure matches that shown in Table 11.0 for the burner supplied. Adjust pressure if required.
- 17) Check the vacuum at the inlet of the fuel pump. Make sure that the vacuum does not exceed the fuel pump manufacturer's limit (consult the pump manufacturer's instructions).
- 18) Close the flame observation cover.
- 19) After chimney has warmed-up to operating temperature, adjust barometric draft regulator for a draft of -0.02 inch w. c. over the fire.

- 20) Check the CO₂ and confirm that it is between the minimum and maximum limits shown in Table 11.0. Adjust if necessary.
- 21) Verify that the smoke level still does not exceed #1 and that the draft over fire is -0.02 inch w.c.
- 22) Turn off the burner and remove pressure gauge. Install and tighten gauge port plug, then restart the burner.
- 23) Check for clean cutoff of the burner. Air in the oil line between fuel pump and nozzle will compress, while burner is running, and expand, when burner shuts off, causing oil line pressure to drop and nozzle drip after burner stops. Cycle burner on and off 5 to 10 times to purge air completely.
- 24) Check thermostat operation by raising or lowering its set point as required, cycling burner on and off.
- 25) Verify primary control operation and safety features according to procedure outlined in the instructions furnished with control.
- 26) Check high limit control operation. Jump thermostat terminals and allow burner to run until boiler water temperature exceeds high limit setting. The burner should shut down, and circulator continue running. Allow the temperature to drop below the control setting. The burner must restart. Boiler installation is not complete unless these checks are made and are satisfactory. Remove thermostat jumper and reconnect thermostat upon check completion.
- 27) After the boiler has operated for approximately 30 minutes, check the boiler and heating system for leaks. Repair any leaks found at once.

After the above checks have been completed, leave thermostat(s) at desired setting. Leave all instructions provided with the boiler with owner or in boiler room, displayed near boiler.



WARNING

ATTEMPTS TO USE BURNERS OR BURNER CONFIGURATIONS OTHER THAN THOSE SHOWN IN TABLE 3 COULD RESULT IN RELIABILITY PROBLEMS, PROPERTY DAMAGE OR UNSAFE OPERATION.

TABLE 11.0a: BECKETT BURNER CONFIGURATION AND SETUP DATA

BOILER MODEL	TWZ065	TWZ075	TWZ100	TWZ090	TWZ125	TWZ150	TWZ120	TWZ175	TWZ200
BURNER MODEL	AFG	AFG	AFG	AFG	AFG	AFG	AFG	AFG	AFG
AIR TUBE COMBO.	70MMAQ	70MMAQ	70MMAQ	70MMAQ	70MDAQ	70MDAQ	70MLAQ	70MLAQ	70MLAQ
HEAD TYPE	L1	L1	L1	L1	V1	V1	V1	V1	V1
STATIC PLATE	3 3/8	3 3/8	3 3/8	3 3/8	2 3/4	2 3/4	NONE	NONE	NONE
LOW FIRING RATE BAFFLE	BECKETT #3708	BECKETT #3708	NONE	NONE	NONE	NONE	NONE	NONE	NONE
INSERTION LENGTH	2 1/4	2 1/4	2 1/4	2 1/4	2 1/4	2 1/4	2 1/4	2 1/4	2 1/4
PITCH ANGLE	2	2	2	2	2	2	2	2	2
STANDARD NOZZLE	HAGO 0.55/60B	HAGO 0.65/60B	HAGO 0.85/60B	DEL. 0.75/60B	HAGO 1.00/60B	HAGO 1.25/60B	HAGO 0.90/60B	HAGO 1.35/45B	HAGO 1.50/45B
ALTERNATE NOZZLE	DEL. 0.55/60W	DEL. 0.65/60W	DEL. 0.85/60W	HAGO 0.75/60B	DEL. 1.00/60B	DEL. 1.25/60B	DEL. 0.90/60B	DEL. 1.35/45B	DEL. 1.50/45B
PUMP PRESS (psi)	140	140	140	140	140	140	175	175	175
HEAD SETTING	NA	NA	NA	NA	0	0	0	3	4
STARTING: SHUTTER SETTING	1	10	5	7	10	10	8	6	8
BAND SETTING	1	2	2	0	0.5	6	1	6	4
DRAFT OVER FIRE (in w.c.)	-0.02	-0.02	-0.02	-0.02	-0.02	-0.02	-0.02	-0.02	-0.02
MAX. SMOKE (bacharach scale)	#1	#1	#1	#1	#1	#1	#1	#1	#1
FLUE CO ₂ (%)									
MIN.	11.0	11.0	11.0	11.0	11.0	11.0	11.0	11.0	11.0
MAX	12.5	12.5	12.5	12.5	12.5	12.5	12.5	12.5	12.5

TABLE 11.0b: CARLIN BURNER CONFIGURATION AND SETUP DATA

BOILER MODEL	TWZ065	TWZ075	TWZ100	TWZ090	TWZ125	TWZ150	TWZ120	TWZ175	TWZ200
BURNER MODEL	EZ-1HP	EZ-1HP	EZ-1HP	EZ-1HP	EZ-1HP	EZ-1HP	EZ-1HP	EZ-2HP	
STANDARD NOZZLE	DEL. 0.55/70B	HAGO 0.60/60ES	HAGO 0.85/60B	DEL. 0.75/60A	DEL. 1.00/60A	HAGO 1.25/60B	HAGO 1.00/60B	DEL. 1.50/60A	
PUMP PRESS (psi)	150	150	150	150	150	150	150	150	
HEAD BAR	0.50	0.60-0.65	0.85-1.00	0.75	0.85-1.00	1.10-1.25	0.85-1.00	1.50	
STARTING BAND SETTING	0.55	0.60	0.75	0.75	1.00-1.10	1.25-1.35	0.90	1.75	
DRAFT OVER FIRE (in w.c.)	-0.02	-0.02	-0.02	-0.02	-0.02	-0.02	-0.02	-0.02	
MAX. SMOKE (bacharach scale)	#1	#1	#1	#1	#1	#1	#1	#1	
FLUE CO2 (%)									
MIN.	11.0	11.0	11.0	11.0	11.0	11.0	11.0	11.0	
MAX	12.5	12.5	12.5	12.5	12.5	12.5	12.5	12.5	

TABLE 11.0c: RIELLO BURNER CONFIGURATION AND SETUP DATA

BOILER MODEL	TWZ065	TWZ075	TWZ100	TWZ090	TWZ125	TWZ150	TWZ120	TWZ175	TWZ200
BURNER MODEL		40F5	40F5		40F5	40F10		40F10	40F10
STANDARD NOZZLE		DEL 0.60/60A	DEL 0.85/60W		DEL 1.00/60A	DEL 1.25/60B		HAGO 1.35/45B	DEL 1.65/45B
PUMP PRESS (psi)		150	150		150	150		150	150
TURBULATOR		0	2		4	1		1.5	2
AIR SHUTTER SETTING		2.60	2.85		4	3		3	3.8
DRAFT OVER FIRE (in w.c.)		-0.02	-0.02		-0.02	-0.02		-0.02	-0.02
MAX. SMOKE (bacharach scale)		#1	#1		#1	#1		#1	#1
FLUE CO2 (%)									
MIN.		11.0	11.0		11.0	11.0		11.0	11.0
MAX		12.5	12.5		12.5	12.5		12.5	12.5

XII Operation

A. General Information

This boiler uses a proprietary version of the Honeywell L7248L Aquastat® cold start control used on boilers less tankless heater or the L7224A Aquastat® warm start control used on boilers with tankless heater. to regulate water temperature and to manage demands for up to two circulator zones.

Crown offers a low water cut-off kit that may be used with this control (PN 411000). Specific information on this kit, along with installation and operating instructions, are available through Crown distributors and at www.crownboiler.com.

In accordance with the 2007 Energy and Independence Security Act, the L7248L cold start control first attempts to use residual heat in the boiler to satisfy a space heating demand before firing the burner. In this manual, this function is referred to as a “thermal purge”. For additional information see Part C of this section.

The L7224A warm start control is capable of thermal purge but it must be set by the installer. Note that using the thermal purge on a warm start control may adversely affect the domestic hot water temperature in the tankless coil.

B. Reading Status and Using Menu

The boiler’s status, as well as all parameters, are viewed and adjusted using the 3 digit LED and three buttons shown in Figure 12.0. The L7248L and L7224A have four basic modes of operation (also see Figure 12.1):

1. **Status Mode** - This is the default mode of operation for the control. In it, the display alternates between *5tH* and a number indicating the current status of the boiler. A list and description of these status numbers is shown in Table 12.2.
2. **Operating Mode** - Provides additional information about the current status of the boiler. Operating mode is entered by pressing the **I** button shown in Figure 12.0. When this button is first pressed in Status mode, the display will alternately display *bt* and the current boiler water temperature as shown in Figure 12.3. Pressing the **I** button again will display the next line item shown in Table 12.2. In the same manner it is possible to advance through all of the “parameters” shown in Table 12.2. To return to Status mode, press **I** repeatedly until *5tH* once again appears on the display. Alternatively, the control will return to Status mode if no key is touched for 1 minute.
3. **Error Mode** - In Error mode, the control alternately displays *Err* and an error code. A list of these error codes is found on the inside of the control cover, as well as in Section XIV of this manual (along with suggested corrective actions).
4. **Adjustment Mode** - Used to change parameters, such as high limit setting. See Part C for using Adjustment Mode.

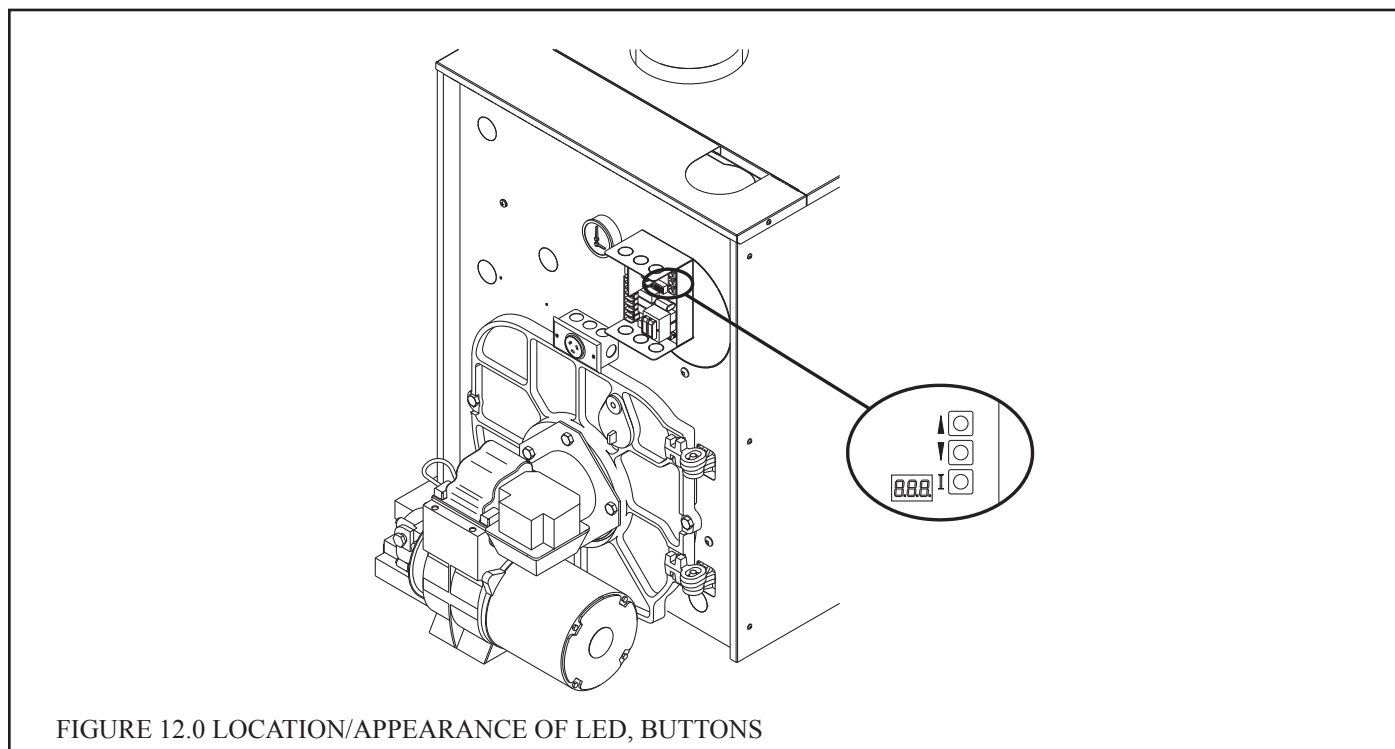
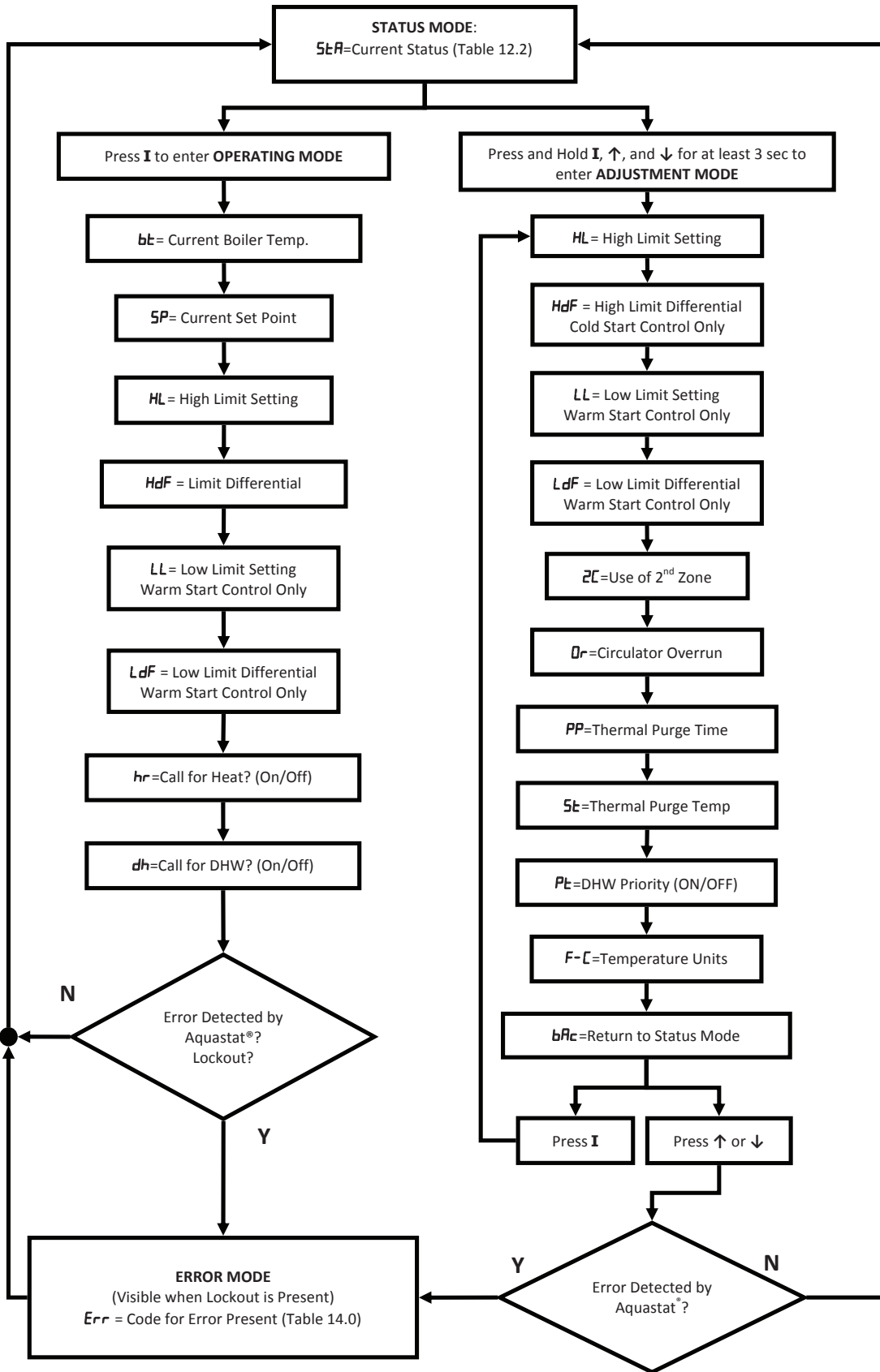

FIGURE 12.1: BOILER CONTROL MENU



- Except as shown above, press **I** to navigate through menu.
- Use **↑, ↓** to change parameters in Adjustment Mode

TABLE 12.2: STATUS CODES

Status #	Description	Meaning
1	Standby	No call for heat or DHW OR Call for heat present , but boiler is in thermal purge (See <i>PP</i> on page 11) OR Call for heat/DHW present but boiler temperature is above set point (<i>SP</i>) setting.
8	Burner Demand	The burner is running OR The burner is off due to an open limit (such as an external high limit or LWCO) OR The burner is being prevented from firing by its primary control.
17	Self test	Boiler was just energized and control is running a self check.

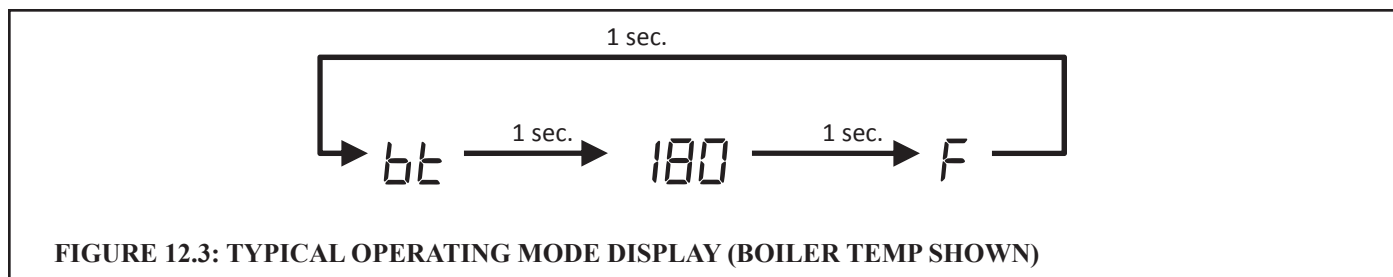

FIGURE 12.3: TYPICAL OPERATING MODE DISPLAY (BOILER TEMP SHOWN)

NOTE

In operating mode, holding either the \uparrow or \downarrow button while viewing a given parameter will keep the display on the actual reading. For example, pressing \uparrow while reading boiler temperature as shown in Figure 12.3 will keep the display on 180 for as long as this button is held. This makes it easier to view readings “live” if they are changing rapidly

TABLE 12.4: OPERATING MODE PARAMETERS

Parameter #	Description	Meaning
<i>bt</i>	Boiler Temperature	Current boiler water temperature measured by the control’s sensor.
<i>SP</i>	Boiler Water Set Point	Current target temperature (always the same as the high limit setting)
<i>HL</i>	High Limit Set Point	Boiler will stop firing if boiler water temperature exceeds this value (Circulator/s will continue to operate)
<i>HdF</i>	High Limit Differential	If high limit setting is reached, boiler water temperature will need to drop by this amount before boiler will again fire during the same call for heat.
<i>LL</i>	Low Limit Set Point (Warm Strat Control)	If the boiler water temperature falls below this point less the differential the circulator is forced off and the burner is turned on. If the boiler water temperature rises above this point the burner is turned off and the circulator is enabled to respond to a call for heat.
<i>LdF</i>	Low Limit Differential (Warm Start Control)	This is the number of degrees the boiler water temperature must decrease below the Low Limit Set Point before the burner is turned on and the water flow through the boiler is turned off.
<i>hr</i>	Heat Request Status	Shown as either ON or OFF. Indicates whether there is a call for heat.
<i>dh</i>	DHW Request Status	Shown as either ON or OFF. Indicates whether there is a demand from the ZR terminal for domestic hot water (DHW). Note that if the dh zone on the L7248L or the L7224A is used as a second heating zone (see Table 12.5), this parameter will be shown as OFF and <i>hr</i> will be shown as ON when a demand from ZR is present.

TABLE 12.5a: ADJUSTMENT MODE PARAMETERS FOR L7248L - COLD START CONTROL

Status #	Description	Factory Setting	Permissible Range
<i>HL</i>	High Limit Set Point	180F	140-240F
<i>HdF</i>	High Limit Differential	15F	10-30F
<i>ZC</i>	ZC and ZR Terminal Function	dh	dh (DHW) OR Zr (2nd Heating Zone) OR ELL (“External Low Limit” - NOT RECOMMENDED)
<i>Or</i>	Circulator Overrun	0 min	0-10 minutes
<i>PP</i>	Thermal Purge Time	2 min	2-20 minutes
<i>St</i>	Thermal Purge Start Temp	140F	140-180F
<i>Pt</i>	DHW Priority	ON	ON or OFF
<i>F-C</i>	Temperature Units	F	F or C
<i>bAc</i>	Exit Adjustment Mode	N/A	N/A

TABLE 12.5b: ADJUSTMENT MODE PARAMETERS FOR L7224A - WARM START CONTROL

Status #	Description	Factory Setting	Permissible Range
<i>HL</i>	High Limit Set Point	180F	140-240F
<i>LL</i>	Low Limit Set Point	110F	110-220F
<i>LdF</i>	Low Limit Differential	10F	10-25F
<i>ZC</i>	ZC and ZR Terminal Function	Zr	Zr (Zone Request, Call for Heat) OR dh (DHW or 2nd Heating Zone if Pt is set to OFF)
<i>Or</i>	Circulator Overrun	0 min	0-10 minutes
<i>PP</i>	Thermal Purge Time	0 min	0-20 minutes
<i>St</i>	Thermal Purge Start Temp	140F	140-180F
<i>Pt</i>	DHW Priority	ON	ON or OFF
<i>F-C</i>	Temperature Units	F	F or C
<i>bAc</i>	Exit Adjustment Mode	N/A	N/A

C. Using Adjustment Mode



WARNING

Improper adjustments to control parameters could result in unreliable boiler operation, property damage, personal injury, or loss of life. Adjustments should only be made by a qualified heating technician.

A list of parameters which can be changed on this control are shown in Table 12.5. To enter Adjustment mode and change parameters:

- 1) Press and hold **I**, **↑**, **↓** together for at least 3 seconds.
- 2) Use **I** to advance to the parameter which is to be changed.
- 3) Use the **↑** or **↓** buttons to change the setting or select from possible choices. See below for additional information on the use of these parameters.
- 4) If other parameters are to be changed, use the **I** button to advance to the next parameter needing adjustment and change it in the same way.
- 5) After all parameters have been changed, use the **I** button to advance until *bFlc* is shown on the display.
- 6) Press either the **↑** or **↓** key to return to Status mode. Alternatively, the control will return to Status mode if no key is touched for 5 minutes.

HL (High Limit Set Point) - Burner shuts down if the boiler water temperature exceeds this setting. The circulator will continue to run. The high limit setting also serves as the water temperature set point (*SP*) during calls for both heat and DHW.

HdF (High Limit Differential) - If the boiler shuts off on high limit, the water temperature must fall by an amount equal to the differential during the same call for heat before the burner will again start. For example, with *HL*=180 and *HdF*=15, the burner will shut off if the water temperature exceeds 180F and stay off until the temperature falls to 165F (180 - 15). Note that if all calls for heat end while the burner is off on high limit, the burner will not restart during the next call for heat until the thermal purge requirements described below are met.

On the Warm Start Boiler Control the High Limit Differential is fixed at 10F.

ZC (ZC and ZR Terminal Functions - Cold Start Boiler Control) - Terminals *ZC* and *ZR* can be used to control a IWH circulator or a second heating zone circulator using a 120VAC thermostat (see Section X). When *ZC*=dh, the L7248L assumes that an indirect water heater circulator is connected to *ZC* and no thermal purge occurs upon a call for DHW before the boiler fires (see thermal purge description below). In addition, a call for DHW will turn off the circulator connected to *C1* and *C2* if DHW priority (*Pt*) is ON.

Setting *ZC* = *Zr* allows the second zone to be used as a heating zone. In this mode, there is no zone priority and a thermal purge occurs regardless of whether the call for heat originates from T-T or *ZR*.

The use of the *ZC*=ELL (“External Low Limit”) is not recommended.

ZC (ZC and ZR Terminal Functions - Warm Start Boiler Control) - Terminals *ZC* and *ZR* can be used to control a second heating zone circulator or an IWH circulator using a 120VAC thermostat or be used to enable pumps in a warm start application (see Section X). When *ZC*=dh, and DWH priority (*Pt*) is OFF, a second heating zone circulator can be connected to *ZC* and *L2*.

Though not recommended unless the tankless heater is removed from the boiler, setting *ZC*=dh and DWH priority (*Pt*) to ON, allows an indirect water heater circulator with priority to be connected to *ZC* and *L2*.

Setting *ZC* = *Zr* energizes the *ZC* terminal while the boiler is warm. The T-T or *ZR* inputs are a call for heat that fires the boiler unless the boiler water temperature falls below the Low Limit Set Point minus the Low Limit Differential in which case the primary heating circulator connected to *C1* and the *ZC* output are de-energized.

Or (Circulator Overrun) - Determines how long the Heating Circulator will operate after the call for heat ends. In some cases, this can help reduce energy consumption by sending heat stored in the boiler out into the system. At the same time, caution should be exercised before setting this value to something other than zero. Before doing so, verify that the system will permit flow (e.g. flow is not completely cut-off by closed zone valves) and that the overrun will not cause overheating problems.

Circulator overrun is only possible on the heating zone controlled by T-T. The ZC Circulator will not over-run, even if it is used as a second heating zone.

PP (Thermal Purge Time) - Upon a call for heat, the boiler will prevent burner operation until either:

- The water temperature drops below the Thermal Purge Start Temperature (5t) OR:
- The thermal purge time has passed

For some examples of this operation, see Table 12.6. If the “ZC” zone is used for space heating (ZC=Zr), this thermal purge function will also keep the burner off at the beginning of a call from the thermostat connected to the “ZR” terminal in the manner described above. If the “ZC” zone is being used for DHW (ZC=dh), the burners will immediately come on upon a call for DHW as long as the water temperature is below the high limit setting.

Thermal purge is only invoked when a call for heat first appears and the boiler is not already firing. For this reason, if the boiler is already firing in response to an call for heat, and a call for heat appears at the second zone, the boiler will continue to fire.

TABLE 12.6 EXAMPLES OF THERMAL PURGE OPERATION

Example #	Call for Heat From	Use of “ZC” Zone	Thermal Purge Settings		Boiler Temp at Begin Call	Boiler Behavior
			Time (Pt)	Start Temp (5t)		
1	T-T	N/A	2 min.	140F	130	<ul style="list-style-type: none"> • “C1-C2” Circulator starts immediately • Burner fires immediately
2	T-T	N/A	2 min.	140F	150	<ul style="list-style-type: none"> • “C1-C2” Circulator starts immediately • Burner fires when either: 2 minutes have passed OR Temperature falls below 140
3	ZR	DHW (ZC=dh)	2 min.	140F	150	<ul style="list-style-type: none"> • “ZC” Circulator starts immediately • Burner fires immediately
4	Heat T’stat on ZR terminals	Heat (ZC=Zr)	2 min.	140F	150	<ul style="list-style-type: none"> • “ZC” Circulator starts immediately • Burner fires when either: 2 minutes have passed OR Temperature falls below 140
5	T-T	N/A	2 min.	145F	150	<ul style="list-style-type: none"> • “C1-C2” Circulator starts immediately • Burner fires when either: 2 minutes have passed OR Temperature falls below 145
6	T-T	N/A	3 min.	140	150	<ul style="list-style-type: none"> • “C1-C2” Circulator starts immediately • Burner fires when either: 3 minutes have passed OR Temperature falls below 140

5t (Thermal Purge Start Temperature) - See description for Thermal Purge Time above.

Pt (DHW Priority) - If this feature is turned on, and simultaneous calls for heat and DHW are present, the heating circulator will be forced off for as long as it takes the boiler to satisfy the call for DHW. This feature is sometimes useful when the boiler size is marginal for the peak DHW demand, but should be used with caution as it can result in lack of heat if the DHW call is very long, or if there is a problem with the DHW zone which causes the DHW demand to be indefinite. Figure 12.7 describes the behavior of both the Heating and DHW Circulators with Pt turned both ON and OFF.

F-C (Temperature Units) - Determines whether temperature units on the L7248L are displayed in F or C. Note that this selection only applies to the temperature displayed on the LED shown in Figure 12.0. Temperature units must be selected independently on the displays of any control options plugged into the EnviraCOM port.

bRc (Return to Status mode) - Exits adjustment mode. Any changes made to the parameters described above are saved, and become effective, as soon as they are made; bRc only exits adjustment mode.

TABLE 12.7a SUMMARY OF CIRCULATOR BEHAVIOR - L7248L - COLD START CONTROL

Thermostat Inputs		Use of “ZC” Zone	Parameters		Circulator Outputs	
T-T	“DHW”		2nd Zone (Zc)	DHW Priority (Pt)	“C1-C2”	“ZC- L2”
ON	OFF	DHW	Zc=dh	On	ON	OFF
OFF	ON	DHW	Zc=dh	On	OFF	ON
ON	ON	DHW	Zc=dh	On	OFF	ON
ON	ON	DHW	Zc=dh	OFF	ON	ON
ON	OFF	DHW	Zc=dh	OFF	ON	OFF
OFF	ON	DHW	Zc=dh	OFF	OFF	ON
ON	OFF	Heat	Zc=Zr	On or OFF	ON	OFF
OFF	ON	Heat	Zc=Zr	On or OFF	OFF	ON
ON	ON	Heat	Zc=Zr	On or OFF	ON	ON

***TABLE 12.7b SUMMARY OF CIRCULATOR BEHAVIOR - L7224A - WARM START CONTROL**

Thermostat Inputs		Use of “ZC” Zone	Parameters		Circulator Outputs	
T-T	“DHW”		2nd Zone (Zc)	DHW Priority (Pt)	“C1-C2”	“ZC- L2”
ON	OFF	DHW	Zc=dh	On	ON	OFF
OFF	ON	DHW	Zc=dh	On	OFF	ON
ON	ON	DHW	Zc=dh	On	OFF	ON
ON	ON	DHW	Zc=dh	OFF	ON	ON
ON	OFF	DHW	Zc=dh	OFF	ON	OFF
OFF	ON	DHW	Zc=dh	OFF	OFF	ON
ON	OFF	Heat	Zc=Zr	On or OFF	ON	ON
OFF	ON	Heat	Zc=Zr	On or OFF	OFF	ON
ON	ON	Heat	Zc=Zr	On or OFF	ON	ON

* Assumes boiler water temperature is above Low Limit Set Point.

XIII Service and Maintenance



WARNING

All boiler cleaning must be completed with the burner service switch turned off. Boilers equipped with burner swing door have a potential hazard which can cause severe property damage, personal injury or loss of life if ignored. Before opening swing door, turn off service switch to boiler to prevent accidental firing of burner outside the combustion chamber. Disconnect the burner plug from the receptacle in the front jacket. Be sure to tighten the swing door fastener completely when service is completed.

The following procedure should be performed on an annual basis:

- 1) Turn off electrical power and oil supply to the boiler.
- 2) Clean the boiler as follows:
 - a) Remove vent connector and piping.
 - b) Remove barometric draft regulator.
 - c) Remove top jacket panel to gain access to boiler flue collector.
 - d) Unscrew four wing nuts and remove canopy retaining carriage bolts, lift off the canopy and ceramic fiber sealing strips.
 - e) Unplug the burner, disconnect the oil lines (if the pump is hard piped), and remove the two 5/16" bolts securing the burner door. Open the burner swing door.
 - f) Thoroughly brush boiler flueways from the top and diagonally between casting pin rows. Be careful when brushing the rear passage not to damage the rear target wall insulation.
 - g) Vacuum soot and debris from combustion chamber.
 - h) Check condition of rear target wall insulation, combustion chamber liner, and burner door insulation; replace if required.
 - i) Check burner head for signs of deterioration. Clean the head of any deposits.
 - j) Close burner door, reinstall 5/16" bolts, reconnect fuel oil and electrical lines.
 - k) Installation of boiler canopy, jacket top panel barometric draft regulator and breeching piping is done in reverse order of removal. Make sure canopy is sealed tight to the casting; replace ceramic fiber sealing strips as needed. All vent piping joints must be flue gas leak free and secured with sheet metal screws.

IMPORTANT

- Clean The Boiler Even If There Are No Significant Soot Deposits. Failure To Remove All Sulfur And Ash Deposits Annually Can Cause Severe Corrosion Damage.
- When Cleaning The Rear Flue Passage, Be Careful Not To Push The Brush Too Far Beyond The Bottom Of The Pins. Doing So May Damage The Target Wall.

- 3) Inspect the vent system:
 - a) Make sure that the vent system is free of obstructions and soot.
 - b) Make sure that all vent system supports are intact.
 - c) Inspect joints for signs of condensate or flue gas leakage.
 - d) Inspect venting components for corrosion or other deterioration. Replace any defective vent system components.

WARNING

The boiler must be connected to an approved chimney in good condition. Serious property damage could result if the boiler is connected to a dirty or inadequate chimney. The interior of the chimney flue must be inspected and cleaned before the start of the heating season and should be inspected periodically throughout the heating season for any obstructions. A clean and unobstructed chimney flue is necessary to allow noxious fumes that could cause injury or loss of life to vent safely and will contribute toward maintaining the boiler's efficiency.

- 4) Service the oil burner:
 - a) Replace oil nozzle with identical make and model (see Table 11.0).
 - b) Inspect the electrodes. Replace if they are deteriorated. Make sure that the electrode position is set according to the burner manufacturer's instructions.
 - c) Remove and clean fuel pump strainer.
 - d) Remove any accumulations of dust, hair, etc. from the air shutter, blower wheel, and other air handling parts of the burner.
- 5) Replace the fuel oil line filter element and gaskets.
- 6) Inspect all oil piping and fittings for kinks and leaks. Repair any found.
- 7) Inspect the hydronic piping, tankless coil gasket, and boiler plugs for water leaks. Repair any leaks found immediately.
- 8) Verify operation of relief valve by manually lifting lever; replace relief valve immediately if valve fails to relieve pressure.
- 9) Open fuel line shut-off valve(s) and restore electrical power to the boiler.
- 10) Fire the boiler and check it out using the procedure outlined in "Start-up and Checkout". This must include checking the burner adjustments using instruments. Check for proper operation of all controls.



WARNING

Water leaks can cause severe corrosion damage to the boiler or other system components. Repair any leaks found immediately.

Important Product Safety Information **Refractory Ceramic Fiber Product**

Warning:

The Parts list designates parts that contain refractory ceramic fibers (RCF). RCF has been classified as a possible human carcinogen. When exposed to temperatures about 1805°F, such as during direct flame contact, RCF changes into crystalline silica, a known carcinogen. When disturbed as a result of servicing or repair, these substances become airborne and, if inhaled, may be hazardous to your health.

AVOID Breathing Fiber Particulates and Dust

Precautionary Measures:

Do not remove or replace RCF parts or attempt any service or repair work involving RCF without wearing the following protective gear:

1. A National Institute for Occupational Safety and Health (NIOSH) approved respirator
 2. Long sleeved, loose fitting clothing
 3. Gloves
 4. Eye Protection
- Take steps to assure adequate ventilation.
 - Wash all exposed body areas gently with soap and water after contact.
 - Wash work clothes separately from other laundry and rinse washing machine after use to avoid contaminating other clothes.
 - Discard used RCF components by sealing in an airtight plastic bag. RCF and crystalline silica are not classified as hazardous wastes in the United States and Canada.

First Aid Procedures:

- If contact with eyes: Flush with water for at least 15 minutes. Seek immediate medical attention if irritation persists.
- If contact with skin: Wash affected area gently with soap and water. Seek immediate medical attention if irritation persists.
- If breathing difficulty develops: Leave the area and move to a location with clean fresh air. Seek immediate medical attention if breathing difficulties persist.
- Ingestion: Do not induce vomiting. Drink plenty of water. Seek immediate medical attention.

XIV Trouble Shooting

A. Combustion

- 1) Nozzles - The selection of the nozzle supplied with the TWZ boiler is the result of extensive testing to obtain the best flame shape and efficient combustion. Other brands of the same spray angle and pattern may be used but may not perform at the expected level of CO₂ and smoke. Nozzles are delicate and should be protected from dirt and abuse. Nozzles are mass-produced and can vary from sample to sample. For all of those reasons a spare nozzle should be part of a serviceman's replacement parts inventory.
- 2) Flame Shape - As seen for the observation port, the flame should appear straight with no sparklers rolling up toward the crown of the chamber. If the flame drags to the right or left, sends sparklers upward or makes wet spots on the chamber walls, the nozzle should be replaced. If the condition persists look for fuel leaks, air leaks, water or dirt in the fuel as described below.
- 3) Fuel Leaks - Any fuel leak between the pump and the nozzle will be detrimental to good combustion results. Look for wet surfaces in the air tube, under the ignitor and around the air inlet. Any such leaks should be repaired as they may cause erratic burning of the fuel and in the extreme case may become a fire hazard.
- 4) Air Leaks - Any such leaks should be repaired as they may cause erratic burning of fuel and in extreme cases may become a fire hazard.
- 5) Gasket Leaks - If CO₂ readings between 11.5% and 12.8% with a #1 smoke cannot be obtained in the breeching, or if odors are observed, look for leaks around the burner mounting gasket, observation door and canopy gasket, or in the breeching below the point where the flue gas sample is taken. Air leakage into the boiler or breeching can cause low CO₂ readings (the lower the firing rate, the greater effect an air leak can have on CO₂ readings). Such leaks can also cause flue gas leakage into the building, resulting in odor complaints.
- 6) Dirt - The use of a fuel filter is good practice. Accidental accumulation of dirt in the fuel system can clog the nozzle or nozzle strainer and produce a poor spray pattern from the nozzle. The smaller the firing rate, the smaller the slots in the nozzle and the more prone to plugging it becomes.
- 7) Water - Water in the fuel in large amounts will stall the fuel pump. Water in the fuel in smaller amounts will cause excessive wear on the pump. More importantly it chills the flame and causes smoke and unburned fuel to pass through the combustion chamber and clog the flueways of the boiler.
- 8) Cold Oil - If the oil temperature near the fuel pump is 40°F or lower, poor combustion or delayed ignition may result. Cold oil is harder for the nozzle to atomize, thus the oil droplets get larger and travel further creating a longer flame. An outside fuel tank that is above grade or has fuel lines in a shallow bury is a good candidate for cold oil. The best solution is to bury the tank and lines deep enough to keep the oil above 40°F. Be sure to follow any state and local codes when burying fuel oil tanks and/or fuel oil lines.
- 9) Start-Up Noise - Delayed ignition is the cause of start-up noises. If it occurs recheck for electrode settings, flame shape, air or water in the fuel lines.
- 10) Shut Down Noise - If the flame runs out of air before it runs out of fuel, an after burn with noise may occur. That may be the result of a faulty cut-off valve in the fuel pump, or it may be air trapped in the nozzle line. It may take several firing cycles for that air to be fully vented through the nozzle. Water in the fuel or poor flame shape can also cause shut down noises.

TEST PROCEDURE FOR FUEL SIDE PROBLEMS

A good test for isolating fuel side problems is to disconnect the fuel system and with a 24" length of tubing, fire the burner out of an auxiliary five gallon pail of clean, fresh, warm #2 fuel oil from another source. If the burner runs successfully when drawing out of the auxiliary pail then the problem is isolated to the fuel or fuel lines being used on the installation.

B. Control System

The following pages contain trouble shooting tables for use in diagnosing control problems. When using these tables the following should be kept in mind:

- 1) This information is only meant to be used by a professional heating technician as an aid in diagnosing boiler problems.
- 2) Where applicable, follow all precautions outlined in the Section XI (Start-up and Checkout).
- 3) In general, these tables assume that there are no loose or miswired electrical connections. Before using these tables inspect all electrical connections on the boiler to make sure that they are tight. Also, check the wiring on the boiler against the wiring diagram in Figures 10.0 or 10.1 and 10.2, as appropriate for the boiler model. Ensure that incoming 120 VAC power polarity is correct and that the boiler is properly grounded.
- 4) All controls on the boiler are tested at least once in the manufacturing process and a defective control or component is generally the least likely cause. Before replacing a component, try to rule out all other possible causes.

C. If Display is Blank

Check for 120 VAC across L1 and L2. If voltage not present turn on system power. If voltage is present check polarity. If polarity is correct replace the control.

D. If Control Shows Err Code

Use Table 14.0 to help identify and correct the cause of the problem.

E. If Control Shows 5E8 Code, but Other Problem Present

If no Err Code is observed (even after repeatedly pressing **I** to cycle through Operation Mode), use Table 14.1 to help identify and correct the cause of the problem.

TABLE 14.0 - ERROR CODES

Error Code	Meaning	Possible Cause
1	Temperature Sensor Fault	<ul style="list-style-type: none"> • Loose connection between sensor and control • Sensor wire damaged • Defective Sensor • Defective control
2	Communication Fault	<ul style="list-style-type: none"> • EnviraCOM wiring is shorted to ground or line voltage • Field wiring to external EnviraCOM device is incorrect.
3	Internal electronics failure	<ul style="list-style-type: none"> • AC power supply frequency problem • Possible internal problem with boiler control. Cycle power to the boiler and replace control if problem persists.
4	Burner Output (B1) Fault	<ul style="list-style-type: none"> • Application of power to B1 from external source (control miswired) • Possible internal problem with boiler control. Cycle power to the boiler and replace control if problem persists.
5	Line voltage error (Supply voltage too high or low)	<ul style="list-style-type: none"> • Power supply voltage is incorrect (should be 120VAC nominal)
6	Open fuse in L7248L or L7224A	<ul style="list-style-type: none"> • Incorrectly wired burner primary control (See Section X).
7	User settings lost (reset to factory defaults)	<ul style="list-style-type: none"> • Clear error by entering and exiting the Adjustment mode (and changing settings back to user values as needed). Replace control if problem persists.
8	Manual Reset Lockout	<ul style="list-style-type: none"> • Set if Err 4 was invoked four times in a row. Check wiring and clear Lockout by pressing all three user keys for 60 seconds.

TABLE 14.1 - FAULTS WITHOUT ERROR CODE PRESENT

Displayed Codes	Problem	Possible Cause
5tA 1 hr OFF dh OFF	Burner and Circulator Off	<ul style="list-style-type: none"> • Thermostat/s not calling for heat • Loose connection in thermostat, zone valve end switch, or zone panel wiring. • Thermostat, zone valve, or zone panel miswired • Defective thermostat, zone valve, or zone panel
5tA 1 hr On	Burner Off Circulator On Boiler Warm	<ul style="list-style-type: none"> • Boiler off on high limit (normal operation) • Boiler off on thermal purge (normal operation - See Table 12.6)
hr On	Heating Circulator Off	<ul style="list-style-type: none"> • Heating Circulator is being forced off on DHW priority (normal operation if Pt=ON - see Table 12.7). • See causes for “DHW Circulator off“ below
dh On	DHW Circulator Off	<ul style="list-style-type: none"> • Loose connection in circulator wiring • Defective circulator • Circulator is running, but system problem is preventing circulation
5tA 8	Burner Off No LEDs illuminated on Burner Primary control	<ul style="list-style-type: none"> • External Limit or LWCO is open. • Burner is unplugged • Loose connection between B1-B2 on L7248L or L7224A and burner • Loose or missing T-T jumper on burner primary control.
5tA 8	Burner Off LED is illuminated on Burner Primary control	<ul style="list-style-type: none"> • Consult burner documentation for cause of problem.

XV Parts

KEY #	DESCRIPTION	QTY. OR CROWN P.N.	QUANTITY PER BOILER OR CROWN P.N.								
			65	75	100	90	125	150	120	175	200
1	HEAT EXCH ASSY. WITH COIL OPENING	1 ea.	270013	270013	270013	270014	270014	270014	270015	270015	270015
1	HEAT EXCH ASSY. LESS COIL OPENING	1 ea.	2700135	2700135	2700135	2700145	2700145	2700145	2700155	2700155	2700155
*	FRONT SECTION WITH COIL OPENING	275050	1 ea.	1 ea.	1 ea.	1 ea.	1 ea.	1 ea.	1 ea.	1 ea.	1 ea.
*	FRONT SECTION LESS COIL OPENING	275052	1 ea.	1 ea.	1 ea.	1 ea.	1 ea.	1 ea.	1 ea.	1 ea.	1 ea.
*	REAR SECTION	275060	1 ea.	1 ea.	1 ea.	1 ea.	1 ea.	1 ea.	1 ea.	1 ea.	1 ea.
*	INTERMEDIATE SECTION	275055	1 ea.	1 ea.	1 ea.	2 ea.	2 ea.	2 ea.	3 ea.	3 ea.	3 ea.
*	LOWER PUSHNIPPLE	275070	2 ea.	2 ea.	2 ea.	3 ea.	3 ea.	3 ea.	4 ea.	4 ea.	4 ea.
*	UPPER PUSHNIPPLE	275075	2 ea.	2 ea.	2 ea.	3 ea.	3 ea.	3 ea.	4 ea.	4 ea.	4 ea.
2	BURNER SWING DOOR HINGE (STANDARD)	275030	2 ea.	2 ea.	2 ea.	2 ea.	2 ea.	2 ea.	2 ea.	2 ea.	2 ea.
3	FRONT SECTION HINGE (STANDARD)	275035	2 ea.	2 ea.	2 ea.	2 ea.	2 ea.	2 ea.	2 ea.	2 ea.	2 ea.
4	SWING DOOR INSULATION	270021	1 ea.	1 ea.	1 ea.	1 ea.	1 ea.	1 ea.	1 ea.	1 ea.	1 ea.
5	5/16-18 X 1-1/2 HX HEAD CAP SCREW	900415	2 ea.	2 ea.	2 ea.	2 ea.	2 ea.	2 ea.	2 ea.	2 ea.	2 ea.
6	5/16 FLAT WASHER	900102	10 ea.	10 ea.	10 ea.	10 ea.	10 ea.	10 ea.	10 ea.	10 ea.	10 ea.
7	5/16-18 X 1 HX HEAD CAP SCREW	900410	4 ea.	4 ea.	4 ea.	4 ea.	4 ea.	4 ea.	4 ea.	4 ea.	4 ea.
8	FLAME INSPECTION COVER	270022	1 ea.	1 ea.	1 ea.	1 ea.	1 ea.	1 ea.	1 ea.	1 ea.	1 ea.
9	5/16-18 X 3/4 HEX HEAD CAP SCREW	900400	1 ea.	1 ea.	1 ea.	1 ea.	1 ea.	1 ea.	1 ea.	1 ea.	1 ea.
10	TARGET WALL (REPLACEMENT KIT)	270025	1 ea.	1 ea.	1 ea.	1 ea.	1 ea.	1 ea.	1 ea.	1 ea.	1 ea.
11	REFRACTORY BLANKET	1 ea.	275003	275003	275003	275004	275004	275004	275005	275005	275005
12	SWING DOOR (STANDARD)	270020	1 ea.	1 ea.	1 ea.	1 ea.	1 ea.	1 ea.	1 ea.	1 ea.	1 ea.
13	BURNER SWING DOOR HINGE (ALTERNATE)	290035	2 ea.	2 ea.	2 ea.	2 ea.	2 ea.	2 ea.	2 ea.	2 ea.	2 ea.
15	FLAME INSPECTION COVER (ALTERNATE)	290022	1 ea.	1 ea.	1 ea.	1 ea.	1 ea.	1 ea.	1 ea.	1 ea.	1 ea.
14	SWING DOOR (ALTERNATE)	290020	1 ea.	1 ea.	1 ea.	1 ea.	1 ea.	1 ea.	1 ea.	1 ea.	1 ea.
20	1/2" x 1" SEALING STRIP	900145	4.0 ft	4.0 ft	4.0 ft	4.8 ft	4.8 ft	4.8 ft	5.7 ft	5.7 ft	5.7 ft
21	FLUE COLLECTOR	1 ea.	270123	270123	270123	270124	270124	270124	270125	270125	270125
22	1/4-20 x 3" CARRIAGE BOLT	900126	2 ea.	2 ea.	2 ea.	2 ea.	2 ea.	2 ea.	2 ea.	2 ea.	2 ea.
23	1/4-20 x 3-1/2" CARRIAGE BOLT	900127	2 ea.	2 ea.	2 ea.	2 ea.	2 ea.	2 ea.	2 ea.	2 ea.	2 ea.
24	1/4" USS FLAT WASHER	90-215	4 ea.	4 ea.	4 ea.	4 ea.	4 ea.	4 ea.	4 ea.	4 ea.	4 ea.
25	1/4-20 WING NUT	900125	4 ea.	4 ea.	4 ea.	4 ea.	4 ea.	4 ea.	4 ea.	4 ea.	4 ea.
30	TANKLESS HEATER GASKET	270001	1 ea.	1 ea.	1 ea.	1 ea.	1 ea.	1 ea.	1 ea.	1 ea.	1 ea.
31	TANKLESS HEATER (OPTIONAL)	270002	1 ea.	1 ea.	1 ea.	1 ea.	1 ea.	1 ea.	1 ea.	1 ea.	1 ea.
33	3/8-16 X 7/8 HX HEAD CAP SCREW	900450	6 ea.	6 ea.	6 ea.	6 ea.	6 ea.	6 ea.	6 ea.	6 ea.	6 ea.
34	3/8 USS FLAT WASHER	90-036	6 ea.	6 ea.	6 ea.	6 ea.	6 ea.	6 ea.	6 ea.	6 ea.	6 ea.

† SEE PAGE 26 FOR WARNING REGARDING THE HANDLING OF PARTS THAT CONTAIN REFRACTORY CERAMIC FIBERS.

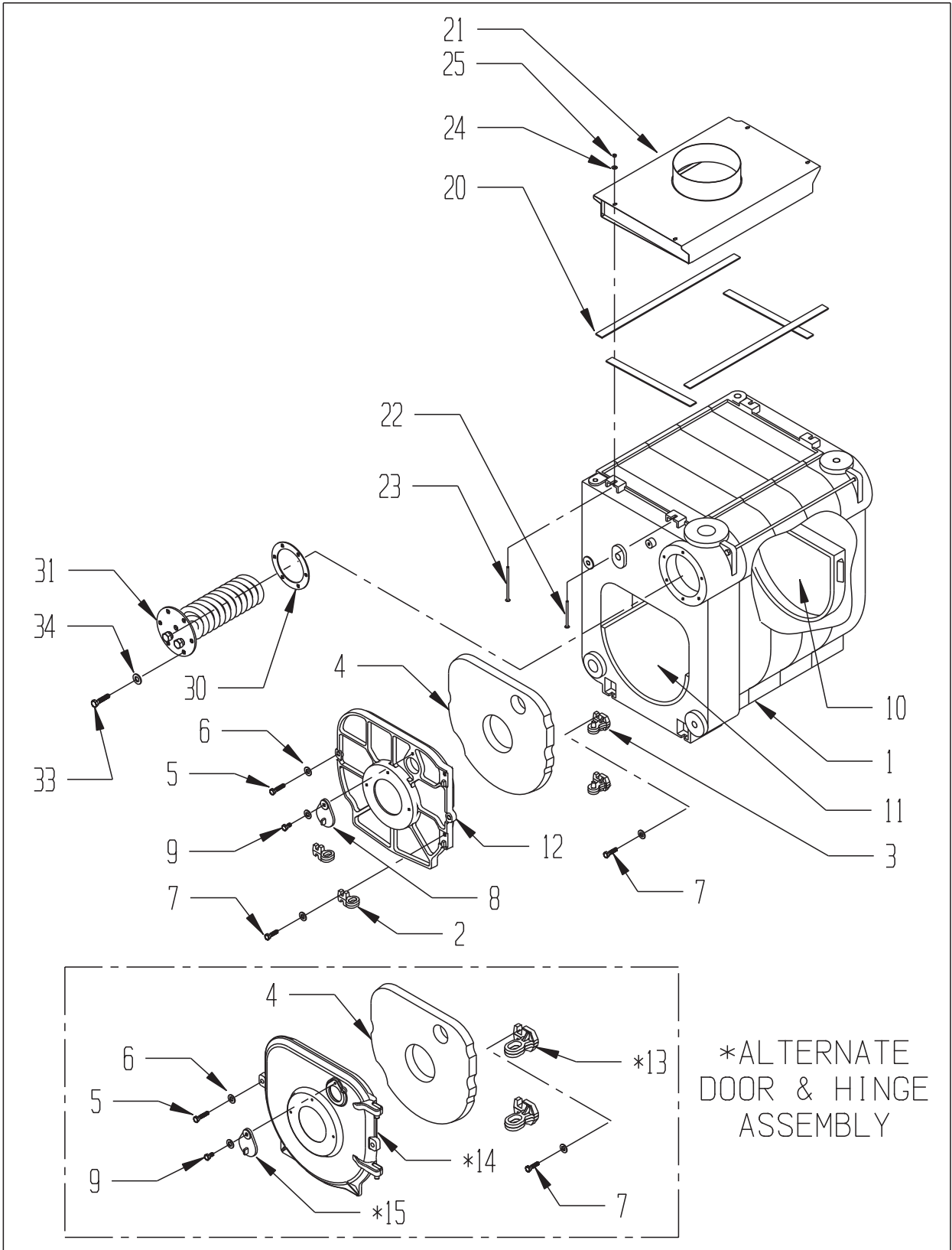

KEY #	DESCRIPTION	QTY. OR CROWN P.N.	QUANTITY PER BOILER OR CROWN P.N.								
			65	75	100	90	125	150	120	175	200
40	REVERSIBLE SIDE JACKET PANEL (RED)	2 ea.	270523	270523	270523	270524	270524	270524	270525	270525	270525
40	REVERSIBLE SIDE JACKET PANEL (GRAY)	2 ea.	290223	290223	290223	290224	290224	290224	290225	290225	290225
*	REAR JACKET PANEL	290220	1 ea.	1 ea.	1 ea.	1 ea.	1 ea.	1 ea.	1 ea.	1 ea.	1 ea.
43	SPLIT REAR TOP JACKET PANEL	1 ea.	290543	290543	290543	290544	290544	290544	290545	290545	290545
44	FRONT JACKET PANEL	290510	1 ea.	1 ea.	1 ea.	1 ea.	1 ea.	1 ea.	1 ea.	1 ea.	1 ea.
45	SPLIT FRONT TOP JACKET PANEL	290215	1 ea.	1 ea.	1 ea.	1 ea.	1 ea.	1 ea.	1 ea.	1 ea.	1 ea.
46	#10 X 1/2" SHEET METAL SCREW	90-212	15 ea.	15 ea.	15 ea.	15 ea.	15 ea.	15 ea.	15 ea.	15 ea.	15 ea.
47	5/16-18 X 1/2 PAN HEAD SCREW	900420	8 ea.	8 ea.	8 ea.	8 ea.	8 ea.	8 ea.	8 ea.	8 ea.	8 ea.
48	1/2" LONG WELL (WITH COIL)	35-1006	1 ea.	1 ea.	1 ea.	1 ea.	1 ea.	1 ea.	1 ea.	1 ea.	1 ea.
48	1/2" SHORT WELL (LESS COIL)	35-1005	1 ea.	1 ea.	1 ea.	1 ea.	1 ea.	1 ea.	1 ea.	1 ea.	1 ea.
49	AQUASTAT (L7224A----) (WITH COIL)	3503----	1 ea.	1 ea.	1 ea.	1 ea.	1 ea.	1 ea.	1 ea.	1 ea.	1 ea.
49	AQUASTAT (L7248L1100) (LESS COIL)	3503025	1 ea.	1 ea.	1 ea.	1 ea.	1 ea.	1 ea.	1 ea.	1 ea.	1 ea.
51	JUNCTION BOX	96-001	1 ea.	1 ea.	1 ea.	1 ea.	1 ea.	1 ea.	1 ea.	1 ea.	1 ea.
54	TWIST RECEPTICAL	96-010	1 ea.	1 ea.	1 ea.	1 ea.	1 ea.	1 ea.	1 ea.	1 ea.	1 ea.
55	TWIST RECEPTICAL UTILITY BOX COVER	96-019	1 ea.	1 ea.	1 ea.	1 ea.	1 ea.	1 ea.	1 ea.	1 ea.	1 ea.
55	BLANK UTILITY BOX COVER	96-002	1 ea.	1 ea.	1 ea.	1 ea.	1 ea.	1 ea.	1 ea.	1 ea.	1 ea.
56	TRIDICATOR GAUGE	95-069	1 ea.	1 ea.	1 ea.	1 ea.	1 ea.	1 ea.	1 ea.	1 ea.	1 ea.
THE FOLLOWING BURNERS HAVE TWIST LOCK PLUGS											
60	BECKETT BURNER ASSY. (NOTE #1)	1 ea.	130511	130512	130513	130514	130515	130516	130517	130518	130519
60	CARLIN BURNER ASSY. (NOTE #1)	1 ea.	130521	130522	130523	130524	130525	130526	130527	130528	130529
60	RIELLO BURNER ASSY. (NOTE #1)	1 ea.		130532	130533		130535	130536		130538	130539
THE FOLLOWING BURNERS HAVE QUICK CONNECT PLUGS FOR MAKING CONNECTION INSIDE JUNCTION BOX											
60	BECKETT BURNER ASSY. (NOTE #1)	1 ea.	130291	130292	130293	130294	130295	130296	130297	130298	130299
60	CARLIN BURNER ASSY. (NOTE #1)	1 ea.	130391	130392	130393	130394	130395	130396	130397	130398	130399
61	5/16-18 X 1 HEX HD SCW (BURNER MOUNT)	900410	3 ea.	3 ea.	3 ea.	3 ea.	3 ea.	3 ea.	3 ea.	3 ea.	3 ea.
*	5/16 FLAT WASHER (BURNER MOUNT)	900102	3 ea.	3 ea.	3 ea.	3 ea.	3 ea.	3 ea.	3 ea.	3 ea.	3 ea.
70	3/4" RELIEF VALVE (30 psi)	95-040	1 ea.	1 ea.	1 ea.	1 ea.	1 ea.	1 ea.	1 ea.	1 ea.	1 ea.
71	CIRCULATOR (TACO 007)	95-012	1 ea.	1 ea.	1 ea.	1 ea.	1 ea.	1 ea.	1 ea.	1 ea.	1 ea.
*	1-1/2" TACO FLANGE SET	950150	1 ea.	1 ea.	1 ea.	1 ea.	1 ea.	1 ea.	1 ea.	1 ea.	1 ea.
*	3/4" BOILER DRAIN	95-041	1 ea.	1 ea.	1 ea.	1 ea.	1 ea.	1 ea.	1 ea.	1 ea.	1 ea.

* NOT PICTURED

NOTE #1: PART NUMBERS PROVIDED ARE FOR FULLY CONFIGURED BURNERS AND INCLUDE NOZZLES, BURNER CORD ASSEMBLIES, AND (WHERE APPLICABLE) LOW FIRING RATE BAFFLES.

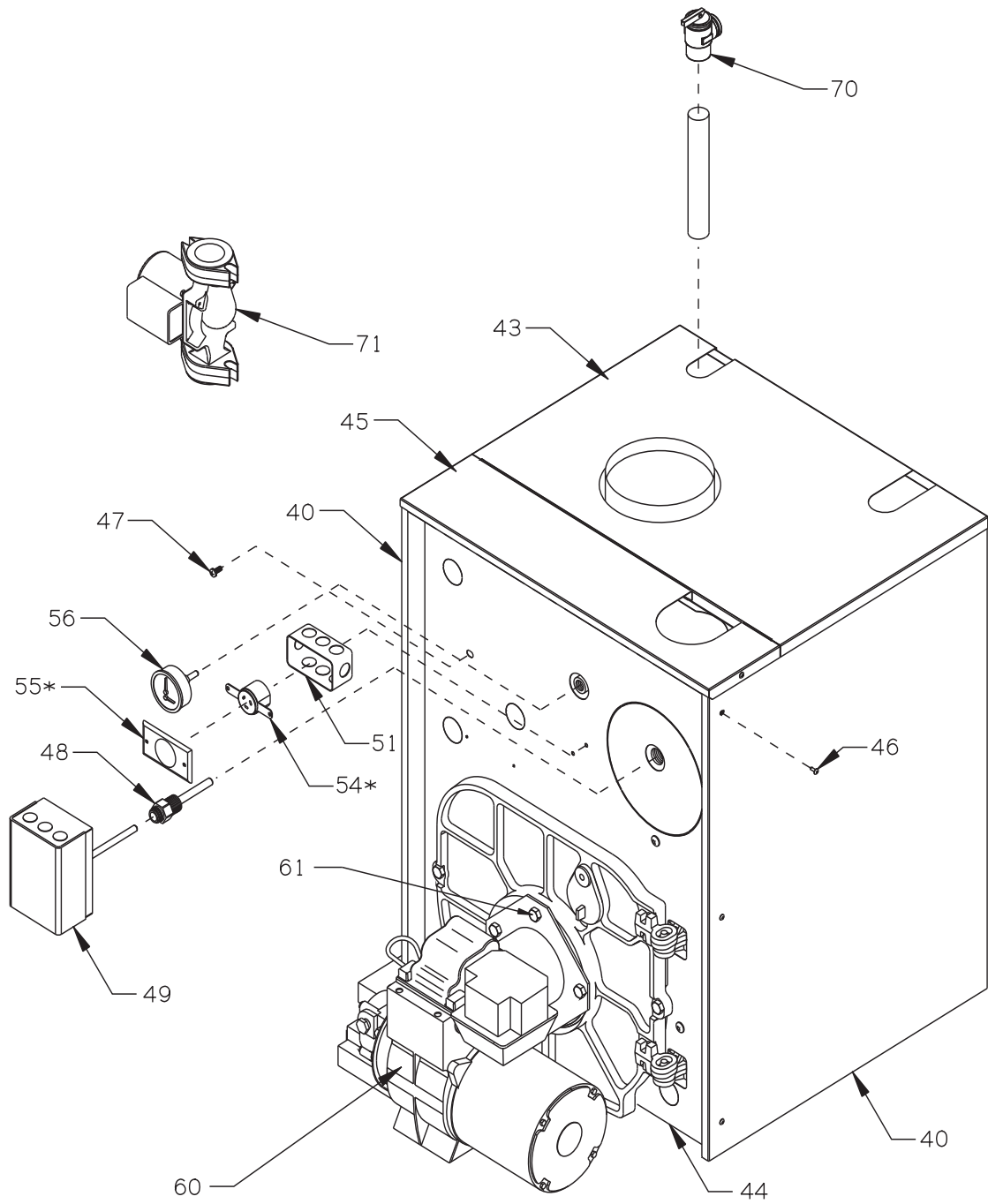

* IN LINE QUICK CONNECT PLUG IN J-BOX SUBSTITUTED FOR TWIST PLUG/RECEPTACLE ON SOME MODELS.



Manufacturer of Hydronic Heating Products
P.O. Box 14818 3633 I. Street
Philadelphia, PA 19134
www.crownboiler.com

PN: 980270 Rev 10
TWZ - 12/12