



**D E S I G N E D T O L E A D**

# CWD Series

Gas-Fired Direct Vent Hot Water Boilers

## INSTALLATION INSTRUCTIONS

These instructions must be affixed on or adjacent to the boiler

### Models:

- CWD060
- CWD083
- CWD110
- CWD138
- CWD165
- CWD193
- CWD220
- CWD245

**WARNING:** Improper installation, adjustment, alteration, service or maintenance can cause property damage, injury, or loss of life. For assistance or additional information, consult a qualified installer, service agency or the gas supplier. Read these instructions carefully before installing.

**Equipped with Honeywell  
S9361A Control System**



Manufacturer of Hydronic Heating Products

P.O. Box 14818 3633 I. Street

Philadelphia, PA 19134

[www.crownboiler.com](http://www.crownboiler.com)





## WARNINGS FOR THE HOMEOWNER

FOLLOW ALL INSTRUCTIONS and warnings printed in this manual and posted on the boiler.

INSPECT THE BOILER ANNUALLY. To keep your boiler safe and efficient, have a service technician follow the Service checklist near the end of this manual.

IF YOU ARE NOT QUALIFIED to install or service boilers, do not install or service this one.

THE BOILER MAY LEAK WATER at the end of its useful life. Be sure to protect walls, carpets, and valuables from water that could leak from the boiler.

PROTECT YOUR HOME IN FREEZING WEATHER. A power outage, safety lockout, or component failure will prevent your boiler from lighting. In winter, your pipes may freeze and cause extensive property damage. Do not leave the heating system unattended during cold weather

unless alarms or other safeguards are in place to prevent such damage

DO NOT BLOCK AIR FLOW into or around the boiler. Insufficient air may cause the boiler to produce carbon monoxide or start a fire.

KEEP FLAMMABLE LIQUIDS AWAY from the boiler, including paint, solvents, and gasoline. The boiler may ignite the vapors from the liquids causing explosion or fire.

KEEP CHILDREN AND PETS away from hot surfaces of the boiler, boiler piping, and vent pipe.

CARBON MONOXIDE (CO) is an odorless, deadly gas that may be introduced into your home by any malfunctioning fuel-burning product or vent system failure. Consider installing CO alarms near bedrooms in all levels of the building to warn you and your family of potential CO exposure.



## WARNINGS FOR THE INSTALLER

READ THIS ENTIRE MANUAL before attempting installation, start-up, or service. Improper installation, adjustment, alteration, service, or maintenance may cause serious property damage, personal injury, or death.

DO NOT DISCONNECT PIPE FITTINGS on the boiler or in the heating system without first verifying that the system is cool and free of pressure and that your clothing will protect you from a release of hot water or steam. Do not rely solely on the boiler's temperature and pressure gage when making this judgment.

USE PROPER PERSONAL PROTECTION EQUIPMENT when servicing or working near the boiler. Materials of construction, flue products, and fuel contain alumina, silica, heavy metals, carbon monoxide, nitrogen oxides, and/or other toxic or harmful substances that can be hazardous to health and life and that are known to the State of California to cause cancer, birth defects, and other reproductive harm.

INSTALL ALL GUARDS, cover plates, and enclosures before operating the boiler.

SIZE THE BOILER PROPERLY relative to the design heat load or, if using domestic hot water priority, the peak hot water load, whichever is larger. A grossly oversized boiler will cycle excessively and this will lead to premature failure of the boiler and its components. Our warranty does not apply to damage from excessive cycling.

ADHERE TO ALL LOCAL CODE REQUIREMENTS. Contact your local code inspector prior to installation. In the absence of a local code, adhere to the *National Fuel Gas Code ANSI Z223.1/NFPA 54* or *CAN/CSA B149.1, Natural Gas and Propane Installation Code*.

ALL WIRING must comply with the *National Electrical Code ANSI/NFPA 70* (in the USA) or the *Canadian Electrical Code CSA C22.1* (in Canada) and any local regulations.

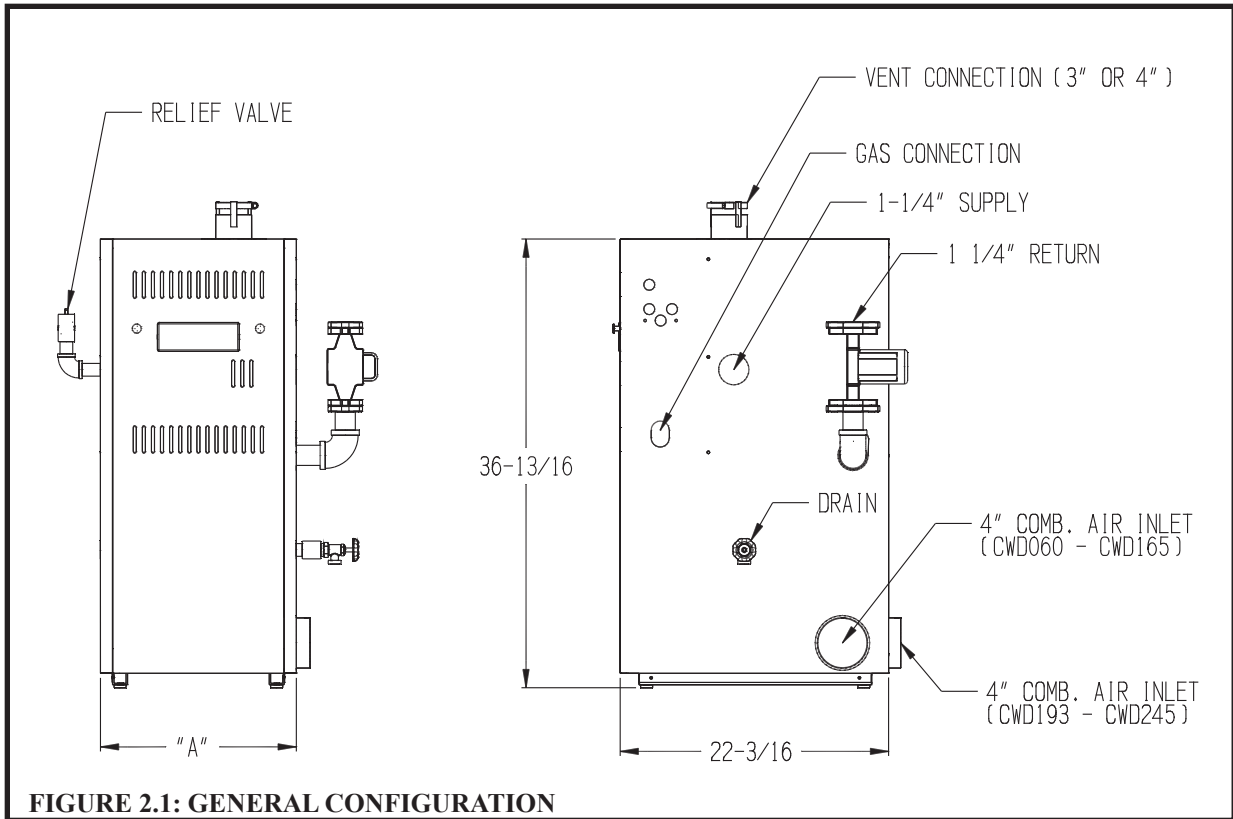
## TABLE OF CONTENTS

I	Product Description	3
II	Specifications	3
III	Before Installing	4
IV	Locating the Boiler	4
V	Air for Combustion and Ventilation	6
VI	Venting	12
	Vent System Design	12
	Vent System Assembly	25
VII	Gas Piping	36
VIII	System Piping	37
IX	Wiring	42
X	Start-up and Checkout	46
XI	Operation	50
XII	Service and Maintenance	58
XIII	Troubleshooting	63
XIV	Parts	67
	Appendix A:Special Requirements for Side-Wall Vented Appliances in the Commonwealth of Massachusetts	76

## I Product Description

The CWD series boiler is a cast iron gas fired boiler designed for use in forced hot water heating systems. It is a low pressure boiler intended for use in closed heating systems with water temperatures under 240F. This boiler may be vented either vertically or horizontally with combustion air supplied from either outdoors or (under certain conditions) indoors. It is ideal for use in installations where a reliable source of clean indoor combustion air cannot be guaranteed.

## II Specifications



**TABLE 2.2: SPECIFICATIONS**

MODEL	SECTIONS	INPUT (MBH)	HEATING CAPACITY (MBH)	NET AHRI RATING, WATER (MBH)	AFUE (%)	FIG 2.1 DIM. "A" (in.)	VENT DIA. (in.)	WATER CONTENT (Gal.)
CWD060	3	60	51	44	85.1	16-1/8	3	2.0
CWD083	4	82.5	71	62	85.1	19-3/4	3	2.6
CWD110	5	110	94	82	85.2	23-3/8	3	3.1
CWD138	6	137.5	118	103	85.2	27	3	3.6
CWD165	7	165	142	123	85.2	30-5/8	3 OR 4	4.2
CWD193	8	192.5	165	143	85.2	34-1/8	3 OR 4	4.7
CWD220	9	220	189	164	85.2	37-3/4	3 OR 4	5.2
CWD245	10	245	211	183	85.3	41-3/8	3 OR 4	5.8

Notes:

The Net AHRI Water Ratings shown are based on a piping and pickup allowance of 1.15.

The manufacturer should be consulted before selecting a boiler for installations having unusual piping and pickup requirements, such as intermittent system operation, extensive piping systems, etc.

### III Before Installing

- 1) Safe, reliable operation of this boiler depends upon installation by a professional heating contractor in strict accordance with this manual and the authority having jurisdiction.
  - In the absence of an authority having jurisdiction, installation must be in accordance with this manual and the *National Fuel Gas Code*, ANSI Z223.1.
  - Where required by the authority having jurisdiction, this installation must conform to the *Standard for Controls and Safety Devices for Automatically Fired Boilers* (ANSI/ASME CSD-1).
- 2) Read Section VI to verify that the maximum combustion air and exhaust pipe lengths will not be exceeded in the planned installation. Also verify that the vent terminal can be located in accordance with Section VI.
- 3) Make sure that the boiler is correctly sized:
  - For heating systems employing convection radiation (baseboard or radiators), use an industry accepted sizing method such as the *I=B=R* Guide RHH published by the Air-Conditioning, Heating and Refrigeration Institute (AHRI).
  - For new radiant heating systems, refer to the radiant tubing manufacturer's boiler sizing guidelines.
  - For systems including a Crown Mega-Stor indirect water heater, size the boiler to have either the Heating Capacity required for the Mega-Stor or the *I=B=R* Net Rating required for the heating system, whichever results in the larger boiler.
  - For systems that incorporate other indirect water heaters, refer to the indirect water heater manufacturer's instructions for boiler output requirements.
- 4) Make sure that the boiler received is configured for the correct gas (natural or LP).
- 5) This boiler is not designed for use with return temperatures under 120F for a sustained period of time. Some systems, such as those having large water contents, may require a return water bypass or other special provisions to protect the boiler against low return temperatures. Failure to provide such provisions if needed could result in severe corrosion damage to the boiler. For more information on when low water temperatures protection is required, and appropriate protection, see Part VIII.
- 6) For installations at altitudes above 2000ft, special orifice and pressure switches are required. Make sure that the boiler is configured for use at the correct altitude.

#### NOTICE

This product must be installed by a licensed plumber or gas fitter when installed within the Commonwealth of Massachusetts. See Appendix A for additional important information about installing this product within the Commonwealth of Massachusetts.

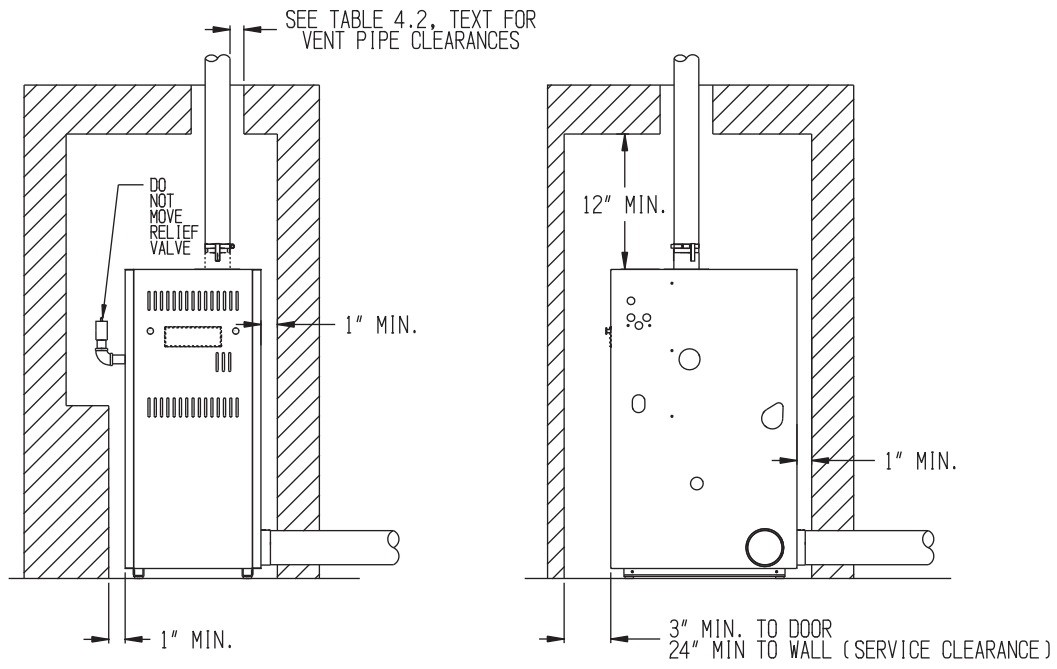
### IV Locating the Boiler



#### WARNING

FAILURE TO OBSERVE THE FOLLOWING LOCATION REQUIREMENTS COULD RESULT IN A FIRE, EXPLOSION OR CARBON MONOXIDE (CO) HAZARD.

- 1) Boiler clearances are shown in Figure 4.1. Figure 4.1a shows clearances from the boiler when outdoor combustion air is used. Figure 4.1b shows clearances from the boiler when combustion air is obtained from the boiler room. These minimum clearances apply to all types of combustible construction as well as noncombustible walls, ceilings and doors. At least 24" must be provided for servicing at the front of the boiler. This front clearance may be provided through a door, such as a closet door. Boiler will be much easier to service if at least 12" is provided from the sides and rear of the boiler to walls.
- 2) Clearances from venting to combustible material depends upon the type of venting, whether the vent pipe is enclosed, and whether the venting is vertical or horizontal. See Table 4.2 for vent clearance information.
- 3) Boiler may be installed on a non-carpeted combustible surface.
- 4) The relief valve must not be moved from the location shown in Figure 2.1.
- 5) When combustion air is obtained from the boiler room, a 10" clearance is required from the side of the boiler having the air inlet collar to combustible or non-combustible obstruction (Figure 4.1b).

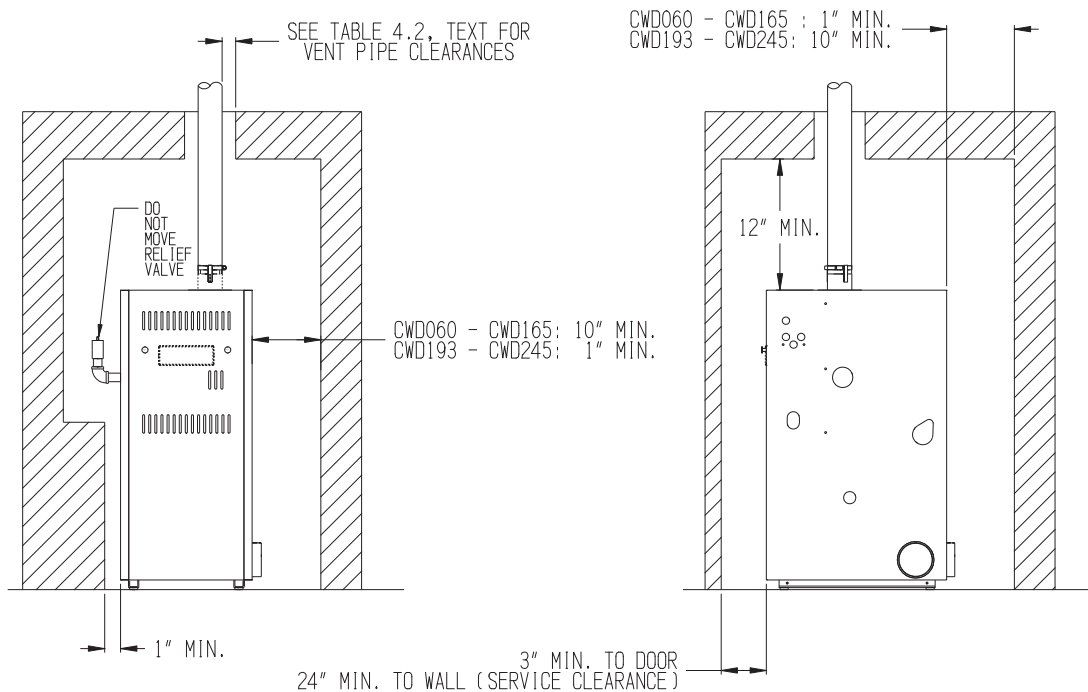


FRONT VIEW

RIGHT SIDE VIEW

BOILER MAY BE INSTALLED DIRECTLY ON NON-CARPETED COMBUSTIBLE FLOOR  
CLEARANCE FROM AIR INTAKE PIPING = 0"

**FIGURE 4.1a: CLEARANCES WHEN BOILER IS DIRECT VENTED (OUTDOOR COMBUSTION AIR IS USED)**



FRONT VIEW

RIGHT SIDE VIEW

BOILER MAY BE INSTALLED DIRECTLY ON NON-CARPETED COMBUSTIBLE FLOOR

**FIGURE 4.1b: CLEARANCES WHEN COMBUSTION AIR IS OBTAINED FROM BOILER ROOM**

**TABLE 4.2: CLEARANCES FROM VENT PIPING TO COMBUSTIBLE CONSTRUCTION**

TYPE OF VENT PIPE	PIPE DIRECTION	ENCLOSURE	MINIMUM CLEARANCE TO COMBUSTIBLE MATERIAL
HEAT FAB SAF-T VENT PROTECH FASNSEAL PROTECH FASNSEAL W2 METAL-FAB CORR/GUARD	VERTICAL OR HORIZONTAL	AT LEAST ONE SIDE OPEN, COMBUSTIBLE MATERIAL ON A MAXIMUM OF THREE SIDES	1"
HEAT FAB SAF-T VENT PROTECH FASNSEAL Z-FLEX Z-VENT III METAL-FAB CORR/GUARD	HORIZONTAL OR VERTICAL WITH OFFSETS	ENCLOSED ON ALL FOUR SIDES	8"
HEAT FAB SAF-T VENT PROTECH FASNSEAL Z-FLEX Z-VENT III METAL-FAB CORR/GUARD	VERTICAL WITH NO OFFSETS	ENCLOSED ON ALL FOUR SIDES	6"
PROTECH FASNSEAL W2	VERTICAL OR HORIZONTAL	ENCLOSED ON ALL FOUR SIDES	3"
HEAT FAB SAF-T VENT SC	VERTICAL OR HORIZONTAL	UNENCLOSED OR ENCLOSED ON ALL SIDES	0"
"B" VENT CHASE USED AS PART OF CROWN COAXIAL VENT SYSTEM*	VERTICAL	PER "B" VENT MANUFACTUER'S INSTRUCTIONS	REFER TO "B" VENT MANUFACTURER'S INSTRUCTIONS

\* "B" Vent is used as a chase to carry combustion air in this system - never attempt to vent a CWD boiler using "B" vent

- 6) The boiler should be located so as to minimize the length of the vent system.
- 7) Do not install this boiler in a location where gasoline or other flammable vapors or liquids will be stored or used. Do not install this boiler in an area where large amounts of airborne dust will be present, such as a workshop. When indoor combustion air is used, do not install in a location where sources of hydrocarbons will be stored or used. Some common sources of hydrocarbons include bleaches, fabric softeners, paints, cleaners, refrigerants, and cat boxes. Traces of these substances can be drawn into the boiler causing severe corrosion damage to the boiler and /or objectionable odors.

### V Air for Combustion and Ventilation



#### **WARNING**

- INSUFFICIENT COMBUSTION AIR SUPPLY MAY RESULT IN THE PRODUCTION AND RELEASE OF DEADLY CARBON MONOXIDE (CO) INTO THE HOME WHICH CAN CAUSE SEVERE PERSONAL INJURY OR DEATH.

Sufficient fresh air must be supplied for both combustion and ventilation. In general, combustion air is obtained in one of two ways:

- Direct Vent Installations – Combustion air is piped directly to the boiler inlet collar from the outdoors. This is also sometimes called a “sealed combustion” installation.
- Direct Exhaust Installations – Combustion air is obtained from the boiler room. In some cases, openings or duct work may be run from the outdoors to the boiler room, however the ducting is not connected directly to the boiler.

Air for ventilation is required to keep various boiler components from overheating and is always obtained from indoors. To ensure an adequate combustion and ventilation air supply, perform the following steps:



## Step 1: Determine whether the boiler is to be installed in a building of unusually tight construction

A good definition of “unusually tight construction” is construction having all of the following features:

- Walls and ceilings exposed to outside atmosphere have a continuous water vapor retarder with a rating of 1 perm or less with openings gasketed and sealed.
- Weather stripping has been added on openable windows and doors.
- Caulking and sealants are applied to areas such as joints around window and door frames, between sole plates and floors, between wall-ceiling joints, between wall panels, at penetrations for plumbing, electrical, and gas lines, and at other openings.

## Step 2: Determine whether the boiler is to be installed in a confined space

A confined space is defined by the National Fuel Gas Code as having a volume less than 50 cubic feet per 1000 BTU/hr input of all appliances installed in that space. To determine whether the boiler room is a confined space:

- 1) Total the input of all appliances in the boiler room in thousands of BTU/hr. Round the result to the next highest 1000 BTU/hr.
- 2) Find the volume of the room in cubic feet. The volume of the room in cubic feet is:

$$\text{Length (ft) x width (ft) x ceiling height (ft)}$$

In calculating the volume of the boiler room, consider the volume of adjoining spaces only if no doors are installed between them. If doors are installed between the boiler room and an adjoining space, do not consider the volume of the adjoining space, even if the door is normally left open.

- 3) Divide the volume of the boiler room by the input in thousands of BTU/hr. If the result is less than 50, the boiler room is a confined space.

Example:

A CWD245 and a water heater are to be installed in a room measuring 6ft – 3 in x 7ft with an 8 ft ceiling. The water heater has an input of 30000 BTU/hr:

$$\text{Total input in thousands of BTU/hr} = (245000 \text{ BTU/hr} + 30000 \text{ BTU/hr}) / 1000 = 275$$

$$\text{Volume of room} = 6.25 \text{ ft} \times 7 \text{ ft} \times 8 \text{ ft} = 350 \text{ ft}^3$$

$$350/275 = 1.27. \text{ Since } 1.27 \text{ is less than } 50, \text{ the boiler room is a confined space.}$$

## Step 3: Decide whether the boiler will be direct vented or direct exhausted

The boiler must be direct vented (combustion air piped directly to the boiler) if:

- The boiler is to be installed in a laundry room
- The building in which the boiler is installed has an indoor pool.
- The boiler is located in an area having any of the contaminants described in Section IV.

It is also strongly recommended that combustion air be piped from outside when the boiler is installed in a building of unusually tight construction.

## Step 4: If the boiler is Direct Vented, Provide Air as Follows (If Indoor Combustion Air is used, Skip to Step 5):

- 1) Combustion air piping must not exceed the maximum lengths called for in Section VI.
- 2) Although combustion air is obtained directly from outdoors, openings may be required into the boiler room to allow for adequate equipment ventilation. The following guidelines apply regardless of whether or not the building is of unusually tight construction:

Unconfined Space– Natural infiltration into the boiler room will provide adequate air for ventilation without additional openings into boiler room.

Confined Space – Provide two openings into the boiler room, one near the floor and one near the ceiling. The top edge of the upper opening must be within 12” of the ceiling and the bottom edge of the lower opening must be within 12” of the

floor (Fig 3). The minimum opening dimension is 3 inches.

- If the CWD boiler is the only gas-burning appliance in the boiler room, these openings must each have a free area of 100 square inches.
- If other gas-burning appliances are in the boiler room, size the openings in accordance with the appliance manufacturer's instructions or the National Fuel Gas Code. Minimum opening free area is 100 square inches regardless of opening requirements for other appliances.
- If the total volume of both the boiler room and the room to which the openings connect is less than 50 cubic feet per 1000 BTU/hr of total appliance input, install a pair of identical openings into a third room. Connect additional rooms with openings until the total volume of all rooms is at least 50 cubic feet per 1000 BTU/hr of input.
- The "free area" of an opening takes into account the blocking effect of mesh, grills, and louvers. Where screens are used, they must be no finer than 1/4" (4 x 4) mesh.

### **Step 5: If Indoor Combustion Air is Used, Provide Air as Follows:**

#### 1) Buildings of other than unusually tight construction:

Unconfined Space– Natural infiltration into the boiler room will normally provide adequate air for combustion and ventilation without additional louvers or openings into boiler room.

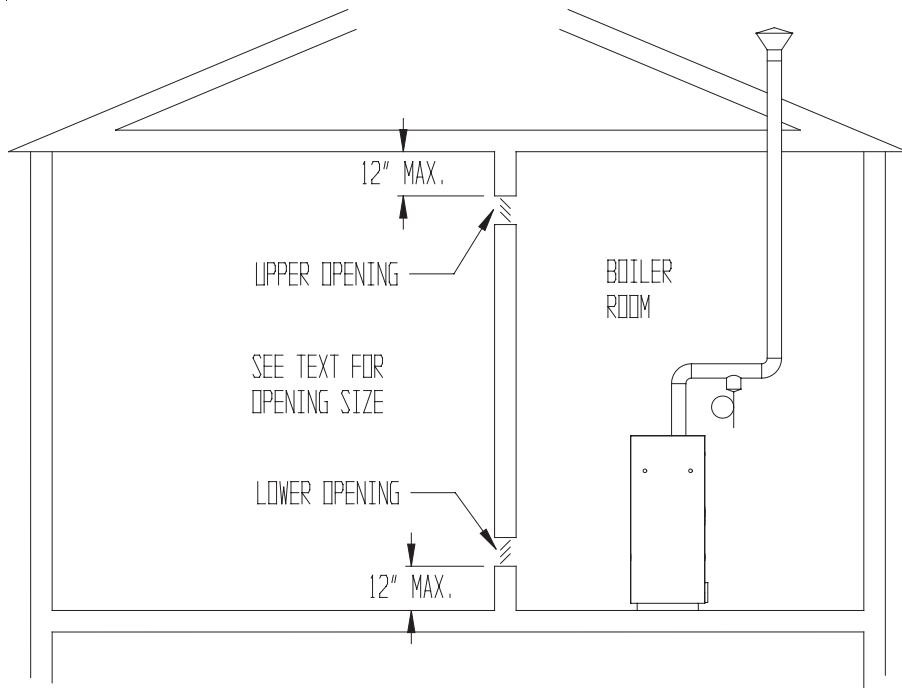
Confined Space – Provide two openings into the boiler room, one near the floor and one near the ceiling. The top edge of the upper opening must be within 12" of the ceiling and the bottom edge of the lower opening must be within 12" of the floor (Fig 5.1).

- Each opening must have a free area of 1 square inch per 1000 BTU/hr input of all gas burning appliances in the boiler room. The minimum opening dimension is 3 inches. Minimum opening free area is 100 square inches per opening.
- If the total volume of both the boiler room and the room to which the openings connect is less than 50 cubic feet per 1000 BTU/hr of total appliance input, install a pair of identical openings into a third room. Connect additional rooms with openings until the total volume of all rooms is at least 50 cubic feet per 1000 BTU/hr of input.
- The "free area" of an opening takes into account the blocking effect of mesh, grills, and louvers. Where screens are used, they must be no finer than 1/4" (4 x 4) mesh.

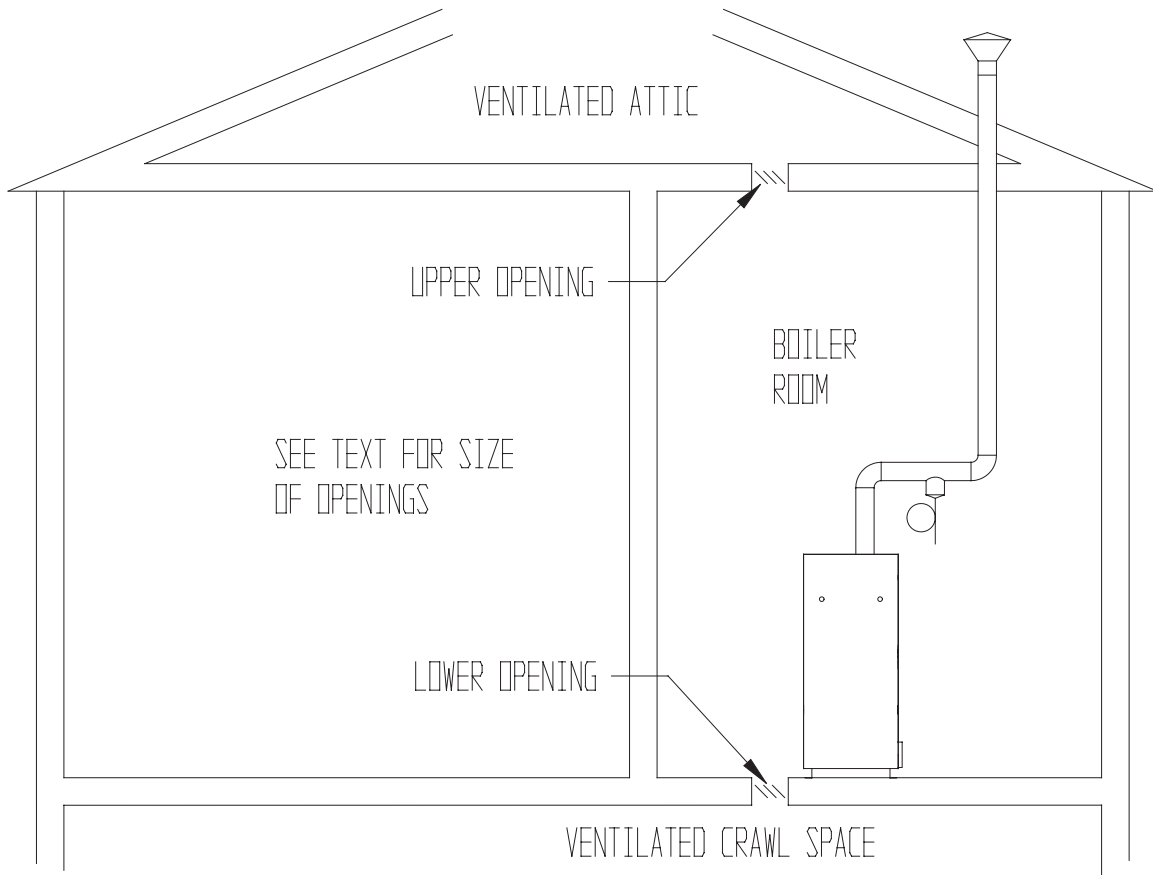
#### 2) Buildings of unusually tight construction:

If at all possible, direct vent the boiler. Where the boiler must be installed in unusually tight construction and cannot be direct vented, openings must be installed between the boiler room and the outdoors or a ventilated space, such as an attic or crawl space, which communicates directly with the outdoors. Two openings are required. The top edge of the upper opening must be within 12 inches of the ceiling. The bottom edge of the lower opening must be within 12 inches of the floor. Size openings and ducts as follows:

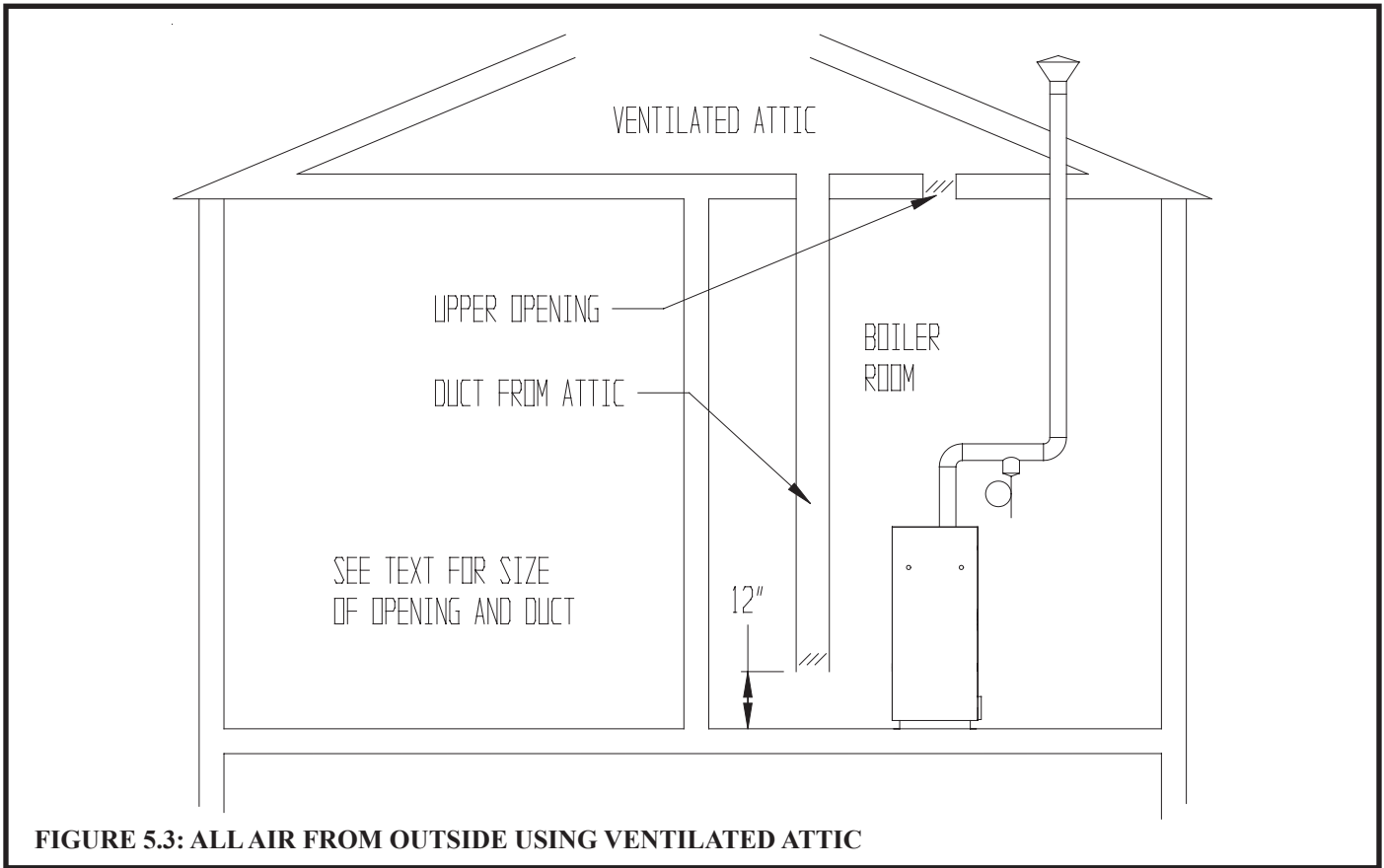
- Vertical ducts or openings directly outdoors (Fig 5.2, Fig 5.3, Fig 5.4) – Each opening must have a free cross sectional area of 1 square inch per 4000 BTU/hr of the total input of all gas-fired appliances in the boiler room but not less than 100 square inches. Minimum opening size is 3 inches.
- Openings to outdoors via horizontal ducts (Fig 5.5) - Each opening must have a free cross sectional area of 1 square inch per 2000 BTU/hr of the total input of all gas fired appliances in the boiler room but not less than 100 square inches. Minimum opening size is 3 inches.
- The "free area" of an opening takes into account the blocking effect of mesh, grills, and louvers. Where screens are used, they must be no finer than 1/4" (4 x 4) mesh.



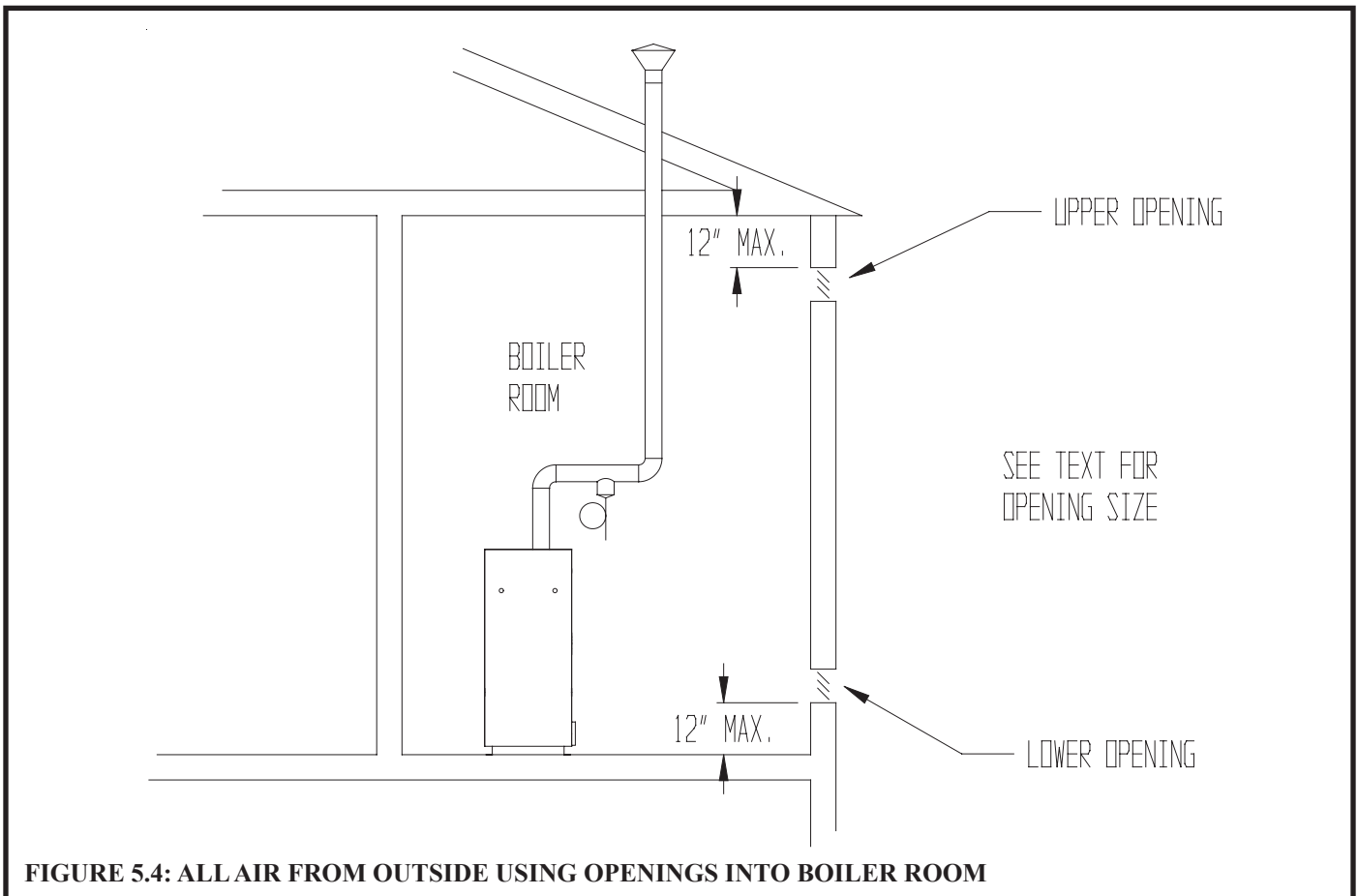
**FIGURE 5.1: BOILER INSTALLED IN A CONFINED SPACE - VENTILATION OR COMBUSTION / VENTILATION AIR FROM INSIDE**



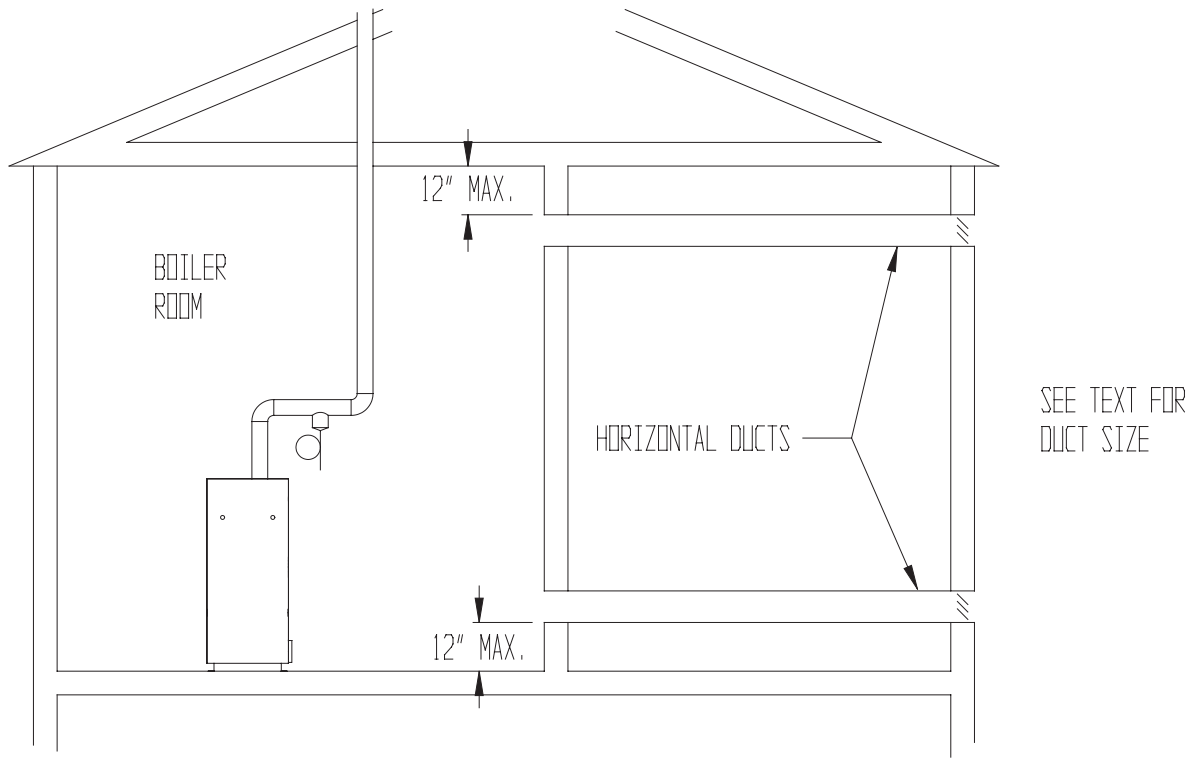
**FIGURE 5.2: ALL AIR FROM OUTSIDE USING VENTILATED CRAWL SPACE AND ATTIC**



**FIGURE 5.3: ALL AIR FROM OUTSIDE USING VENTILATED ATTIC**



**FIGURE 5.4: ALL AIR FROM OUTSIDE USING OPENINGS INTO BOILER ROOM**



**FIGURE 5.5: ALL AIR FROM OUTSIDE USING HORIZONTAL DUCTS INTO BOILER ROOM**

## VI Venting



### WARNING

- FAILURE TO VENT THIS BOILER IN ACCORDANCE WITH THESE INSTRUCTIONS MAY RESULT IN UNRELIABLE BOILER OPERATION, PROPERTY DAMAGE AND/OR THE RELEASE OF FLUE GASES, WHICH CONTAIN DEADLY CARBON MONOXIDE (CO), INTO THE HOME, WHICH CAN CAUSE SEVERE PERSONAL INJURY OR DEATH.
- DO NOT ATTEMPT TO VENT THIS BOILER WITH GALVANIZED, PVC, OR ANY OTHER VENT SYSTEM NOT LISTED IN TABLE 6.8.
- DO NOT ATTEMPT TO MIX COMPONENTS FROM DIFFERENT APPROVED VENT SYSTEMS.
- DO NOT INSTALL A BAROMETRIC DAMPER OR DRAFTHOOD ON THIS BOILER.
- DO NOT ATTEMPT TO USE THE VENT SYSTEM FOR THIS BOILER WITH ANY OTHER APPLIANCE.
- MOISTURE AND ICE MAY FORM ON THE SURFACES AROUND THE VENT TERMINATION. TO PREVENT DETERIORATION, SURFACES SHOULD BE IN GOOD REPAIR (SEALED, PAINTED, ETC.)

### A. Vent System Design

There are three basic ways to vent the CWD boiler:

- **Horizontal (“side wall”) Venting** - Vent system exits the building through an outside wall. Combustion air is either obtained through a separate pipe from outside (a “direct vent” installation) or obtained from the boiler room (a “direct exhaust” installation).
- **Vertical Non-Coaxial Venting** - Vent system exits the building through a roof. Combustion air is either obtained through a separate pipe from outside (a “direct vent” installation) or obtained from the boiler room (a “direct exhaust” installation).
- **Vertical Coaxial Venting** - Vent system exits the building through a roof. A portion of the vent system is coaxial, meaning that it consists of a “pipe within a pipe”. Flue gasses exit the building through the inner pipe and combustion air is drawn through the space between the two pipes.

For each of the above three basic methods, there are several variations, resulting in a total of 13 options for venting the CWD boiler. A description of each of these venting options is listed in Tables 6.1a-6.1c. For clarity, these vent options are numbered from 1 to 13 in Table 6.1. **One of the vent option columns in Table 6.1 must match the planned vent and air intake system exactly.** In addition, observe the following guidelines:

- 1) Approved vent systems - Use only one of the approved vent systems shown in Table 6.8. These systems are made of a special stainless steel alloy (AL29-4C) for protection against corrosive flue gas condensate. They are also designed to provide a gas tight seal at all joints and seams so that flue gas does not enter the building. Each approved vent system has unique method for installation - do not attempt to mix components from different vent systems. The only exceptions are:
  - Heat Fab Saf-T Vent SC may be combined with Saf-T Vent EZ Seal.
  - Protech FasNSeal W2 may be combined with Protech FasNSeal.

See the vent installation section of this manual for information on how this can be done.

Heat Fab Saf-T Vent SC is a double wall vent system which can be used in two ways on CWD installations. In vertical coaxial vent systems (Vent Options 12 and 13), the space between the inner and outer pipes is used as a conduit to bring combustion air to the boiler. In Horizontal (Vent Options 1 to 5) and Vertical (Option 6 to 10) vent systems, Saf-T Vent SC can be used to obtain a 0” clearance to combustible construction. When this is done, the space between the inner and outer pipes is used for ventilation, but boiler combustion air comes from elsewhere.

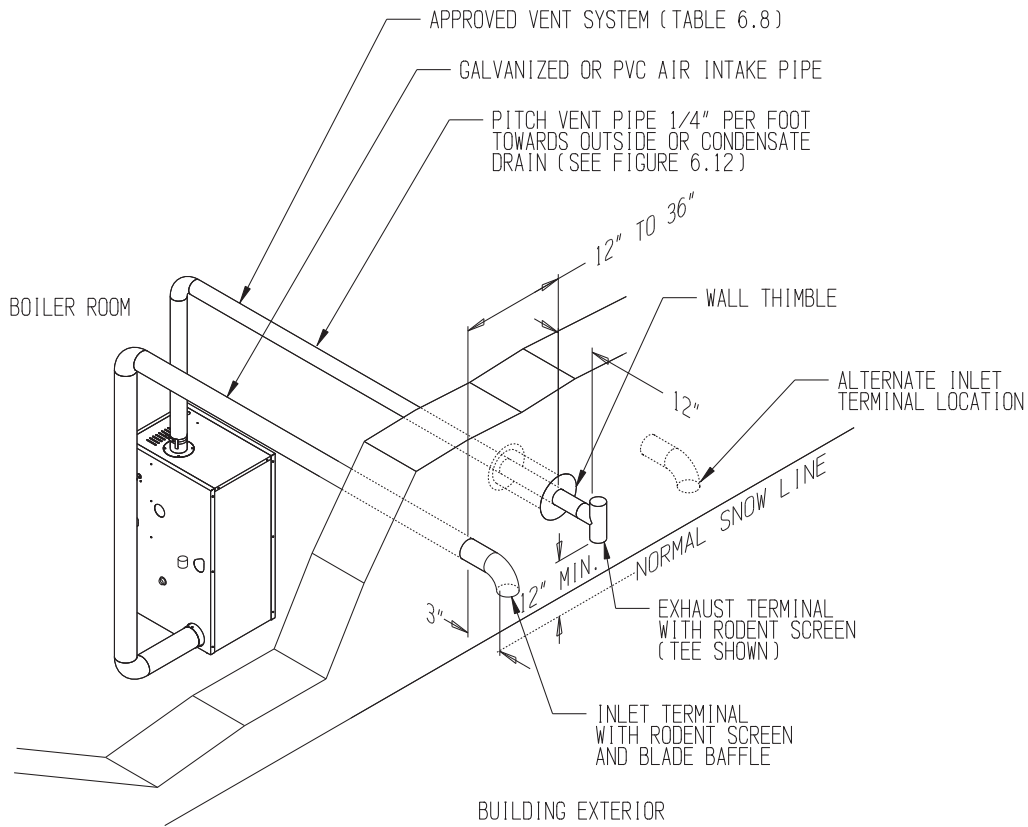
Protech FasNSeal W2 is also a double wall vent system. In some cases, it can be used to obtain closer clearances to combustible construction than are possible using Protech FasNSeal (see Table 4.2). The space between the inner and outer pipes on FasNSeal W2 cannot be used as a combustion air conduit.

The Crown Vertical coaxial vent system (Vent Option 11) is similar to that constructed using Heat Fab Saf-T Vent SC except it is constructed by running one of the 3” single wall vent systems shown in Table 6.8 inside 5” type “B” vent. The space between the 3” vent and the “B” vent forms a conduit to bring combustion air to the boiler. The advantage of this system is that it can be constructed using any of the vent systems shown in Table 6.8 except for Heat Fab Saf-T Vent SC and Protech FasNSeal W2. No turns are permitted in the coaxial section of this system.

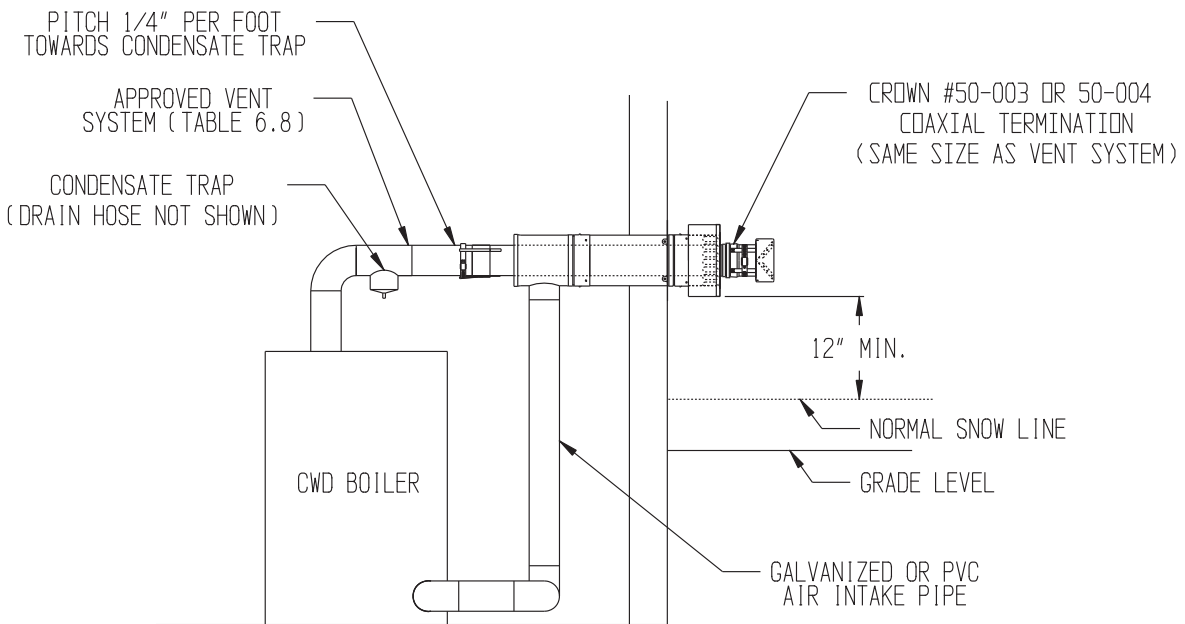
**TABLE 6.1a: SUMMARY OF HORIZONTAL VENTING OPTIONS**

VENT OPTION #		1	2	3	4	5
CLASSIFICATION USED IN THIS MANUAL		HORIZONTAL DIRECT VENT	HORIZONTAL DIRECT VENT	(RESERVED FOR FUTURE USE)	HORIZONTAL DIRECT EXHAUST	HORIZONTAL DIRECT EXHAUST
ILLUSTRATED IN FIGURE		6.2a OR 6.2b	6.2a OR 6.2b		6.3	6.3
VENT PIPE STRUCTURE PENETRATION		WALL	WALL		WALL	WALL
AIR INTAKE PIPE STRUCTURE PENETRATION		WALL	WALL		N.A.	N.A.
VENT PIPE SIZE		3"	4"		3"	4"
AIR INTAKE PIPE SIZE		4"	4"		N.A.	N.A.
MAXIMUM VENT PIPE LENGTH	CWD060 - CWD138	55 FT	55 FT		55 FT	55 FT
	CWD165	35 FT	55 FT		35 FT	55 FT
	CWD193	25 FT	55 FT		25 FT	55 FT
	CWD220	15 FT	55 FT		15 FT	55 FT
	CWD245	N.R.	55FT		10 FT	55 FT
MAXIMUM INTAKE PIPE LENGTH	CWD060 - CWD138	60 FT	60 FT		N.A.	N.A.
	CWD165	40 FT	60 FT		N.A.	N.A.
	CWD193	30 FT	60 FT		N.A.	N.A.
	CWD220	20 FT	60 FT		N.A.	N.A.
	CWD245	N.R.	60 FT		N.A.	N.A.
EXHAUST TERMINAL		3" 90 ELBOW, TEE, OR CROWN COAXIAL TERMINAL #50-003	4" 90 ELBOW, TEE, OR CROWN COAXIAL TERMINAL #50-004	3" 90 ELBOW OR TEE	4" 90 ELBOW OR TEE	
AIR INTAKE TERMINAL		4" 90 ELBOW OR CROWN COAXIAL TERMINAL #50-003	4" 90 ELBOW OR CROWN COAXIAL TERMINAL #50-004	N.A.	N.A.	
VENT MATERIAL		APPROVED VENT SYSTEM SHOWN IN TABLE 6.8				
AIR INTAKE MATERIAL		GALVANIZED OR PVC			N.A.	N.A.

"N.R." - Not recommended "N.A." - Not applicable

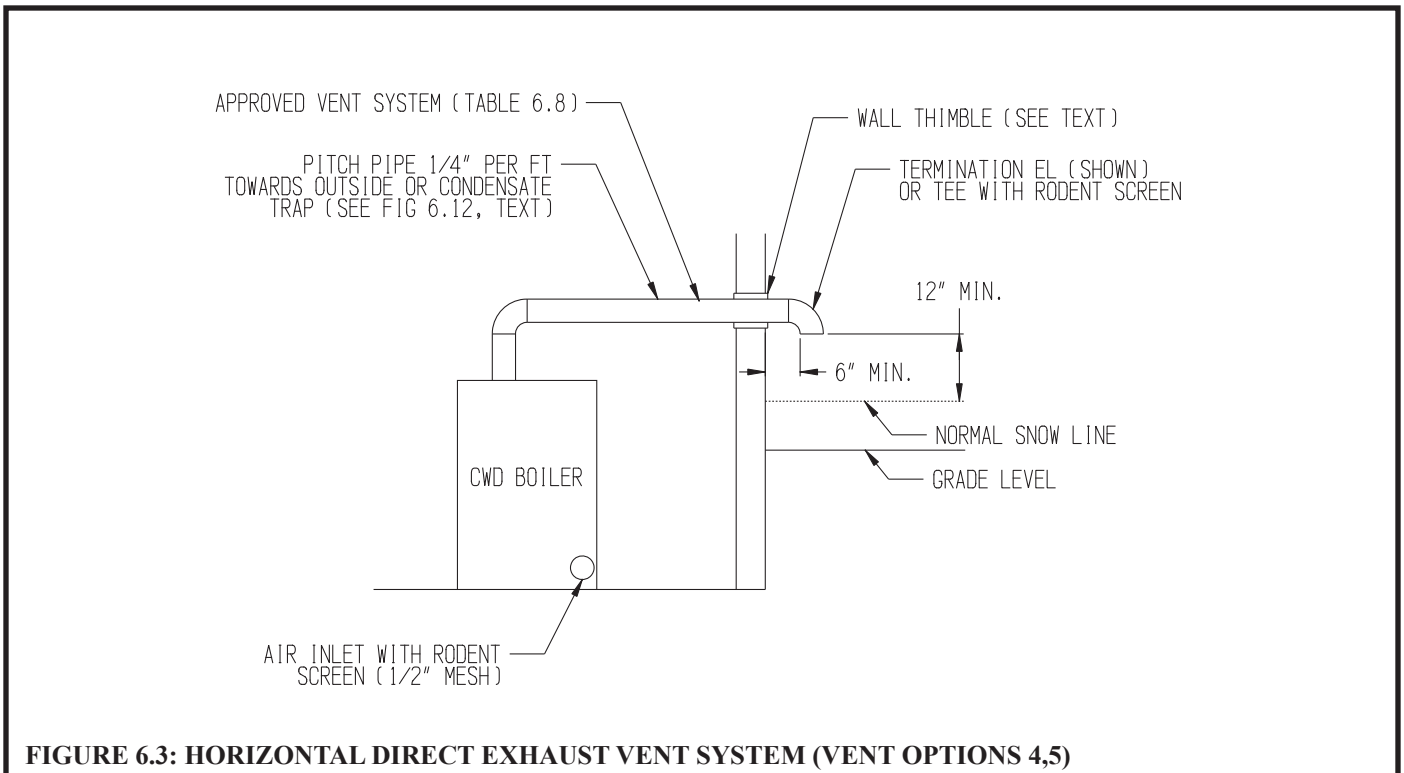


**FIGURE 6.2a: HORIZONTAL DIRECT VENTING USING SEPARATE TERMINALS (VENT OPTIONS 1-2)**



**FIGURE 6.2b: HORIZONTAL DIRECT VENTING USING COAXIAL TERMINAL (VENT OPTIONS 1-2)**





**FIGURE 6.3: HORIZONTAL DIRECT EXHAUST VENT SYSTEM (VENT OPTIONS 4,5)**

2) Maximum Vent and Air Intake Lengths - The maximum length of the vent air intake piping depends upon the vent option selected, the vent pipe size, and the boiler size. See Table 6.1 for the maximum vent length. In addition to the maximum length of piping shown in Table 6.1, the following fittings may also be used:

- Horizontal Vent Systems: One 90 deg. elbow
- Vertical Vent Systems: Two 90 deg. elbows
- Vertical Coaxial Vent Systems: Two 90 deg. elbows
- Air Intake Systems: Two 90 deg. elbows

If additional elbows are desired, the maximum allowable vent length must be reduced by the amount shown in Table 6.9 for each additional elbow used. Note: Termination fittings do not need to be counted when counting additional elbows.

*Example:*

*A 3" vent system is planned for a horizontal direct vented CWD165 which has the following components:*

- 2 ft vertical pipe*
- 1 90 elbow*
- 5 ft horizontal pipe*
- 1 90 elbow*
- 3 ft horizontal pipe*
- 1 45 elbow*
- 4 ft horizontal pipe*
- 1 termination elbow*

*The Vent Option #1 column in Table 6.1a describes a horizontal direct vent system using 3" vent pipe. From this column, we see that a CWD165 may vent length of up to 35ft. The first 90 elbow and the termination elbow are not considered. From Table 6.9, the equivalent length of the 3" 45 elbow is 4ft and the equivalent length of the 3" 90 degree elbow is 5.5ft. The maximum allowable run of straight pipe on this system is therefore:*

$$35ft - 4ft - 5.5ft = 25.5ft$$

*Since the planned installation has only 14 ft of straight pipe, the planned vent length is acceptable.*

3) Minimum Vent / Exhaust Pipe Length - Minimum vent length is 2ft. Minimum air inlet length is 0ft.

- 3) Permitted Terminals for Horizontal Venting (Vent Options 1 - 5) - Table 6.1a shows permitted types of terminals for both the vent and air inlet systems. On horizontal direct vent systems using 4" air inlet pipe (Vent Options 1 and 2), the following Crown co-axial terminals may be used. These terminals have the advantage of requiring only one wall penetration. Part numbers for the Crown coaxial terminals are as follows:

- 3" Vent - 50-003
- 4" Vent - 50-004

When separate vent and air intake terminals are used, or when the boiler uses indoor combustion air, the vent terminal is either a tee or an elbow supplied by the vent system manufacturer and equipped with a rodent screen. Vent system manufacturer's part numbers for these fittings are shown in Table 6.8. In some cases, the elbows and tees shown in Table 6.8 require separate adaptors and/or rodent screens. When this is the case, vent manufacturer part numbers for these additional parts are shown in Table 6.8 along with the termination fitting.

When Heat Fab Saf-T Vent SC is used, the Heat Fab 5300CI or 5400CI fitting is used between the last piece of Saf-T Vent CI and the terminal. These fittings physically adapt from the CI pipe to the terminal and also provide ventilation openings which must remain open for the Saf-T Vent CI to maintain its clearance rating.

Except when the Crown 50-003 or 50-004 coaxial terminals are used, the air intake fitting on a horizontal direct vent system (Options 1 - 2) is always a 90 degree elbow with a rodent screen. This elbow is made out of the same material as the rest of the air inlet system (either galvanized or PVC) and is installed as shown in Figure 6.2a.

- 4) Horizontal vent terminal location - Observe the following limitations on the vent terminal location (also see Fig 6.11a - d):

- Direct exhaust installations (installations using indoor combustion air) - Exhaust terminal must be at least 4 feet below or 4 feet horizontally from any window, door, or gravity air inlet into the building.
- Direct vent installations - Exhaust elbow or coaxial terminal must be at least 1 foot from any door, window, or gravity inlet into the building.
- Direct vent installations using termination elbows - Maintain the correct clearance and orientation between the inlet and exhaust elbows. The elbows must be at the same level and their center lines must be between 12 and 36 inches apart.
- The bottom of the exhaust elbow, tee, or coaxial terminal must be at least 12" above the normal snow line. In no case should it be less than 12" above grade level.
- The bottom of the exhaust elbow, tee, or coaxial terminal must be at least 7 feet above a public walkway.
- The bottom of the exhaust elbow, tee, or coaxial terminal must be at least 3 feet above any forced air inlet located within 10 feet.
- A clearance of at least 4 feet horizontally or 4 feet vertically must be maintained between the exhaust terminal and gas meters, electric meters, regulators, and relief equipment.
- Do not locate the terminal under decks or similar structures.
- Top of exhaust elbow, tee, or coaxial terminal must be at least 4 feet below eaves, soffits, or overhangs. Overhang may not exceed 3 feet (Figure 6.11d).
- Terminal must be at least 3 feet from an inside corner.
- Under certain conditions, water in the flue gas may condense on the structure in areas around the terminal. If these areas are made of materials subject to damage by flue gas condensate, they should be protected.
- If possible, install the terminal on a wall away from the prevailing wind. Reliable operation of this boiler cannot be guaranteed if the terminal is subjected to winds in excess of 40 mph.
- The noise level in the vicinity of the terminal is approximately 65 dB (roughly the level of a normal conversation). Avoid positioning the terminal in areas where this might be objectionable.

- 5) Horizontal air intake terminal location - Horizontal air intake terminal must be at least 12" above the normal snow line.

- 6) Permitted Terminals for Vertical Venting (Vent Options 6 - 10) - Terminals used on these systems are caps. Vent manufacturer part numbers for these caps are shown in Table 4. When Heat Fab Saf-T Vent SC is used, the 5300CI or 5400CI fitting is used between the highest piece of Saf-T Vent CI and the cap. These fittings physically adapt from the CI pipe to the cap and also provide ventilation openings which must remain open for the Saf-T Vent CI to maintain its clearance rating.

Vertical direct vent systems (Vent Options 6 - 8) can have combustion air obtained from either a vertical or horizontal air intake system. When combustion air is obtained from the roof, the air inlet terminal consists of a 180 degree elbow (or two 90 degree elbows) with a rodent screen as shown in Figure 6.4. When combustion air is obtained through a horizontal vent system, the air inlet termination is a 90 degree elbow with a rodent screen as shown in Figure 6.2a.

- 7) Permitted terminals for Vertical Coaxial Venting (Options 11 - 13) - When the Crown vertical coaxial vent kit is used (Vent Option 11), a cap compatible with the vent system is used (Figure 6.6, Table 6.8). The concentric air intake hood supplied in the Crown kit is the air inlet terminal (Figure 6.6).

When vertical coaxial venting is done using Heat Fab Saf-T Vent SC (Options 12, 13), the vent terminal is a SC03VT or SC04VT terminal installed with a 5300CI or 5400CI adaptor. The openings in this adaptor are used for combustion air.

**TABLE 6.1b: SUMMARY OF VERTICAL VENTING OPTIONS**

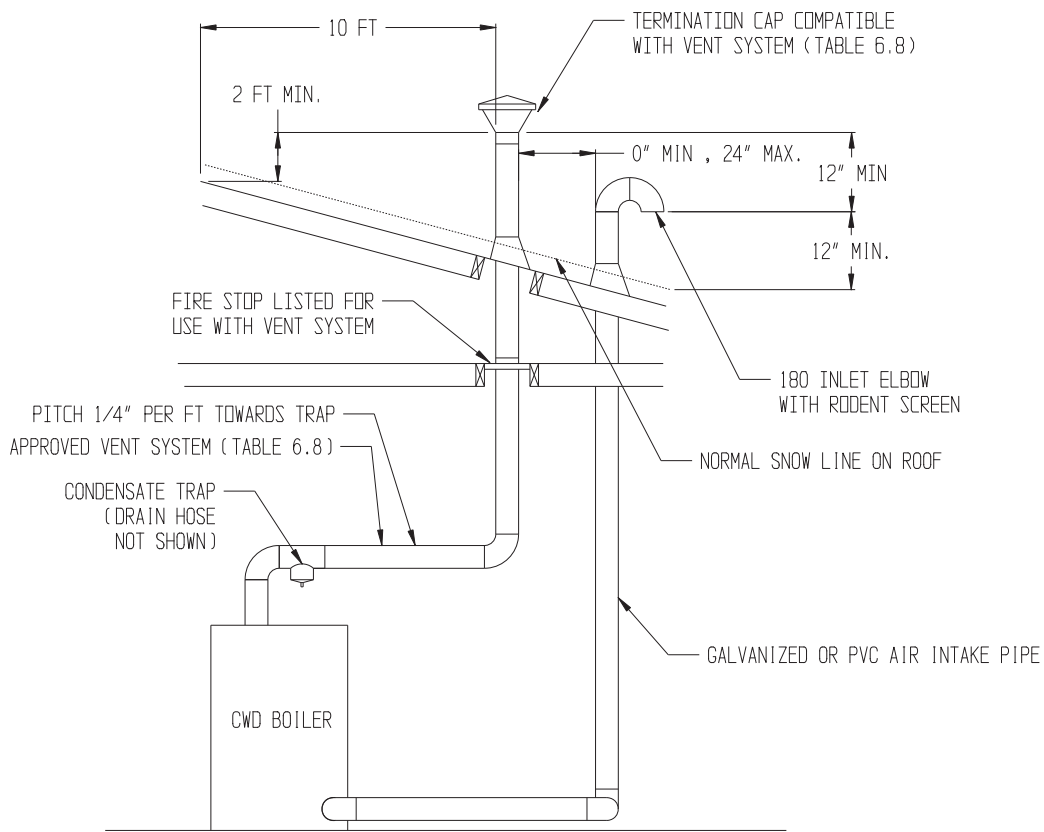
VENT OPTION #		6	7	8	9	10
CLASSIFICATION USED IN THIS MANUAL		VERTICAL DIRECT VENT	VERTICAL DIRECT VENT	(RESERVED FOR FUTURE USE)	VERTICAL DIRECT EXHAUST	VERTICAL DIRECT EXHAUST
ILLUSTRATED IN FIGURE		6.4	6.4		6.5	6.5
VENT PIPE STRUCTURE PENETRATION		ROOF	ROOF		ROOF	ROOF
AIR INTAKE PIPE STRUCTURE PENETRATION		ROOF OR WALL	ROOF OR WALL		N.A.	N.A.
VENT PIPE SIZE		3"	4"		3"	4"
AIR INTAKE PIPE SIZE		4"	4"		N.A.	N.A.
MAXIMUM VENT PIPE LENGTH	CWD060 - CWD138	47 FT	47 FT		47 FT	47 FT
	CWD165	27 FT	47 FT		27 FT	47 FT
	CWD193	17 FT	47 FT		17 FT	47 FT
	CWD220	N.R.	47 FT		N.R.	47 FT
	CWD245	N.R.	47 FT		N.R.	47 FT
MAXIMUM INTAKE PIPE LENGTH	CWD060 - CWD138	52 FT	50 FT		N.A.	N.A.
	CWD165	32 FT	50 FT		N.A.	N.A.
	CWD193	22 FT	50 FT		N.A.	N.A.
	CWD220	N.R.	50 FT		N.A.	N.A.
	CWD245	N.R.	50 FT		N.A.	N.A.
EXHAUST TERMINAL		BY VENT SYSTEM MANUFACTURER. SAME DIAMETER AS VENT SYSTEM. SEE TABLE 4.				
AIR INTAKE TERMINAL (ROOF PENETRATION)		4" 180 ELBOW	4" 180 ELBOW	N.A.	N.A.	
AIR INTAKE TERMINAL (WALL PENETRATION)		4" 90 ELBOW	4" 90 ELBOW	N.A.	N.A.	
VENT MATERIAL		APPROVED VENT SYSTEM SHOWN IN TABLE 6.8				
AIR INTAKE MATERIAL		GALVANIZED OR PVC			N.A.	N.A.

"N.R." - Not recommended "N.A." - Not applicable

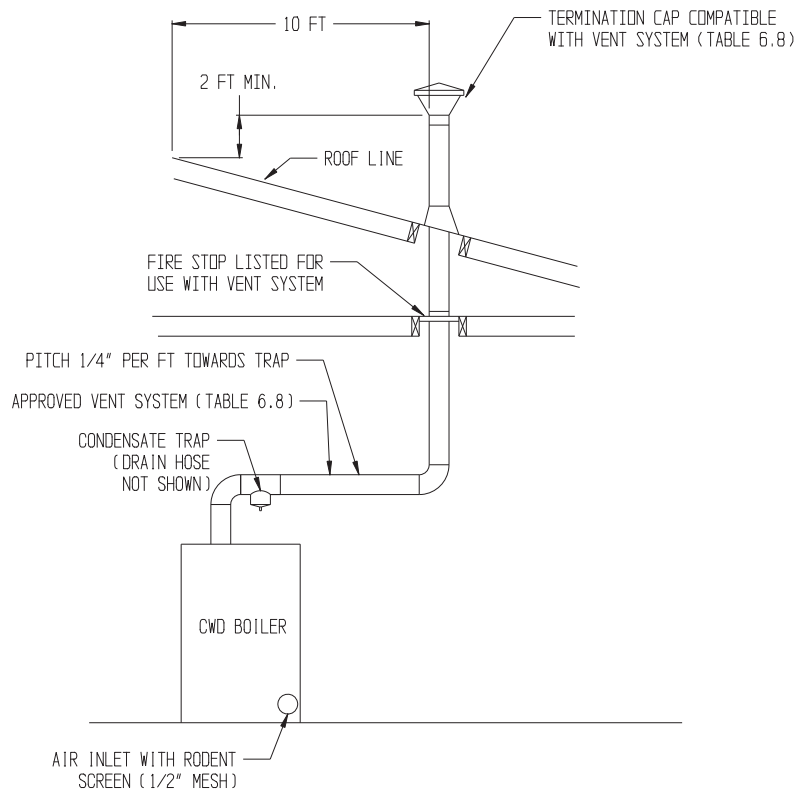
- 8) Vertical Vent Terminal Locations (Vent Options 6 - 13) - Observe the following limitations on the location of all vertical vent terminals (see Figs. 6.4, 6.5, 6.6, 6.7):
  - The lowest discharge opening on the cap must be at least 2 feet above any object located within 10 feet.
  - If outside air is used for combustion (Options 6-7, 11-13), the vertical distance between vent and air inlet terminal openings must be at least 12".
  - The bottom of the air inlet terminal must be at least 12" above the normal snow accumulation that can be expected on the roof.
  
- 9) Terminal offsets - Horizontal elbow or tee terminals may be offset by as much as 5 ft as shown in Figure 6.10. This sometimes helps maintain the 12" minimum clearance required above the snow line. The extra two elbows and the section of vertical pipe on the outside of the building must be counted when checking that the maximum vent / intake pipe length is not exceeded. On horizontal direct vent systems, both terminals must be offset by the same amount so that their relationship to one another is the same as shown in Figure 6.2a. When this offset is used, the horizontal section of vent pipe must be pitched away from the outside so that condensate cannot collect in the lower offset elbow.
  
- 10) Wall thimbles – Wall thimbles are required where the vent pipe passes through combustible walls with less than the required clearance shown in Table 4.2 or as required by local codes. Vent manufacturer’s wall thimble part numbers are shown in Table 6.8.
  
- 11) Condensate Traps and Pitch of Horizontal piping – All horizontal vent piping must be pitched 1/4" per foot so that any condensate which forms in this piping will run towards either the outdoors or into a condensate trap. Vent manufacturer’s part numbers for suitable condensate traps are shown in Table 6.8.
 

All vertical vent systems must include at least one condensate trap as shown in Figures 6.4-6.7. This will collect any condensate that forms in the vent system as well as any rain water that gets around the vent cap.

The maximum allowable vertical run directly off of the boiler without a condensate trap is 7.5 ft (Figure 6.12). Install a condensate trap in longer vertical runs so that condensate which might form in this first vertical section will not run into the boiler fan.



**FIGURE 6.4: VERTICAL NON-COAXIAL DIRECT VENT SYSTEM (VENT OPTIONS 6, 7)**

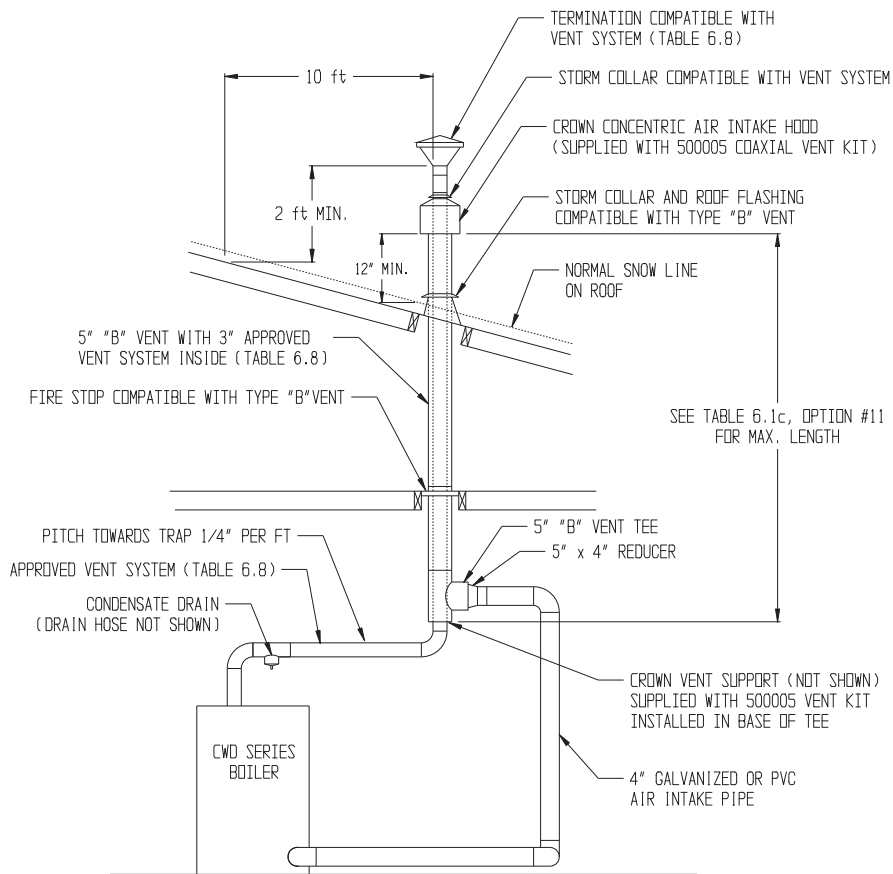


**FIGURE 6.5: VERTICAL DIRECT EXHAUST SYSTEM (VENT OPTIONS 9, 10)**

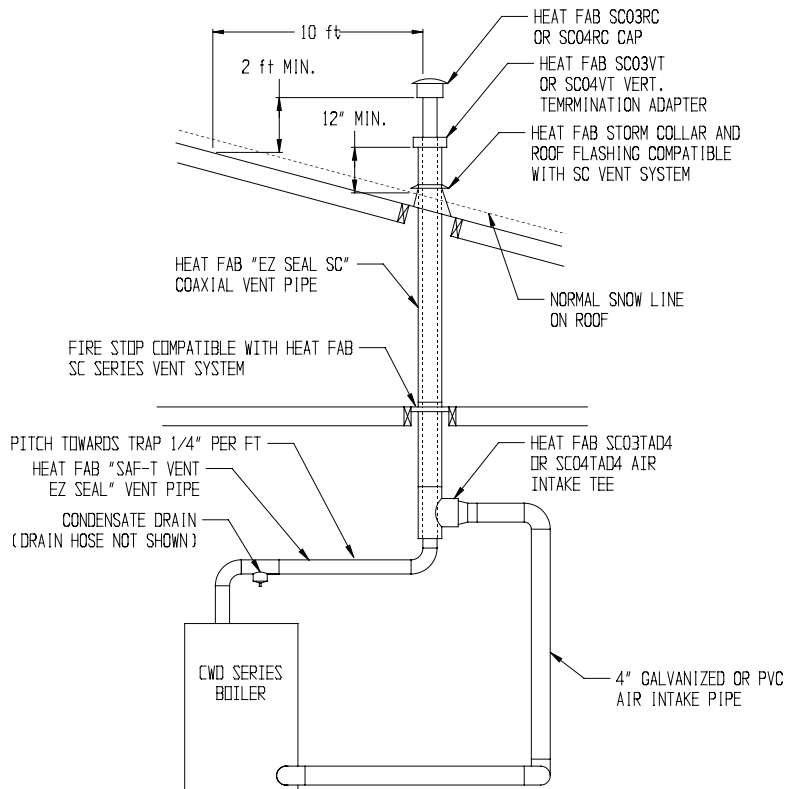
**TABLE 6.1c : SUMMARY OF VERTICAL COAXIAL VENTING OPTIONS**

VENT OPTION #		11	12	13
CLASSIFICATION USED IN THIS MANUAL		VERTICAL COAXIAL DIRECT VENT	VERTICAL COAXIAL DIRECT VENT	VERTICAL COAXIAL DIRECT VENT
VENT PIPE STRUCTURE PENETRATION		ROOF	ROOF	ROOF
AIR INTAKE PIPE STRUCTURE PENETRATION		ROOF	ROOF	ROOF
VENT PIPE SIZE		3"	3"	4"
AIR INTAKE PIPE SIZE (NON-COAXIAL SECTION)		4"	4"	4"
AIR INTAKE PIPE SIZE (COAXIAL SECTION)		5"	5"	7"
MAXIMUM VENT PIPE LENGTH	CWD060 - CWD138	47 FT	47 FT	47 FT
	CWD165	27 FT	27 FT	CONSULT FACTORY
	CWD193	N.R.	N.R.	
	CWD220	N.R.	N.R.	
	CWD245	N.R.	N.R.	
MAXIMUM LENGTH COAXIAL SECTION		30 FT OR AS LIMITED BY MAX VENT LENGTH, WHICHEVER IS LESS	AS LIMITED BY MAX VENT LENGTH	CONSULT FACTORY
MAXIMUM INTAKE PIPE LENGTH	CWD060 - CWD138	52 FT	50 FT	50 FT
	CWD165	32 FT	32 FT	CONSULT FACTORY
	CWD193	N.R.	N.R.	
	CWD220	N.R.	N.R.	
	CWD245	N.R.	N.R.	
EXHAUST TERMINAL		BY VENT SYSTEM MANUFACTURER. SAME DIAMETER AS VENT SYSTEM. SEE TABLE 6.8.	HEAT FAB #SC03RC	HEAT FAB #SC04RC
AIR INTAKE TERMINAL		SUPPLIED WITH CROWN #500005 COAXIAL VENT KIT	HEAT FAB #SC03VT	HEAT FAB #SC04VT
ADAPTOR FROM NON-COAXIAL TO COAXIAL SECTIONS		5" "B" VENT TEE + SUPPORT SUPPLIED WITH CROWN #500005 COAXIAL VENT KIT	HEAT FAB #SC03TAD4	HEAT FAB #SC04TAD4
VENT MATERIAL (NON-COAXIAL SECTION)		APPROVED VENT SYSTEM SHOWN IN TABLE 6.8	HEAT FAB SAF-T VENT	HEAT FAB SAF-T VENT
VENT MATERIAL (COAXIAL SECTION)		APPROVED VENT SYSTEM SHOWN IN TABLE 6.8	HEAT FAB SAF-T VENT SC	HEAT FAB SAF-T VENT SC
AIR INTAKE MATERIAL (NON-COAXIAL SECTION)		GALVANIZED OR PVC		
AIR INTAKE MATERIAL (COAXIAL SECTION)		5" TYPE "B" VENT	HEAT FAB SAF-T VENT SC	HEAT FAB SAF-T VENT SC

"N.R." - Not recommended "N.A." - Not applicable



**FIGURE 6.6: VERTICAL COAXIAL DIRECT VENT USING CROWN #50005 VENT KIT (VENT OPTION 11)**



**FIGURE 6.7: VERTICAL COAXIAL DIRECT VENT USING HEAT FAB SAF-T VENT SC (VENT OPTIONS 12, 13)**

**TABLE 6.8: PERMISSIBLE VENT SYSTEMS AND PRINCIPLE VENT COMPONENTS**

MANUFACTURER	VENT SYSTEM	SIZE	CONDENSATE TRAP	WALL THIMBLES	HORIZONTAL TERMINATION	VERTICAL TERMINATION
HEAT FAB	SAF-T VENT EZ SEAL	3	9321 (NOTE 3)	7393GC 7393GCS 5391CI	ELBOW: 7314TERM TEE: 7390TEE	5300CI
		4	9421 (NOTE 3)	7493GC 7493GCS 5491CI	ELBOW: 7414TERM TEE: 7490TEE	5400CI
	SAF-T VENT SC	3	SC03DRN (NOTE 3)	SC03FS SC03FSA	ELBOW (NOTE 5): SC03HT + 7314TERM TEE (NOTE 5): SC03HT + 7390TEE	5300CI + SC03VT (NOTE 6)
		4	SC04DRN (NOTE 3)	SC04FS SC04FSA	ELBOW (NOTE 5): SC04HT + 7414TERM TEE (NOTE 5): SC04HT + 7490TEE	5400CI + SC04VT (NOTE 6)
PROTECH SYSTEMS INC.	FASNSEAL	3	FSHDT3	FSWT3	ELBOW: FSELB9003 + FSBS3 TEE: FSTT3	FSRC3
		4	FSHDT4 OR FSCD4 (NOTE 4)	FSWT4	ELBOW: FSELB9004 + FSBS4 TEE: FSTT4	FSRC4
	FASNSEAL W2	3	W2-T3 +W2-DF3	W2-WT3	ELBOW: FSA-SWDW3 + FSELB9003 + FSBS3 TEE: FSA-SWDW3 + FSTT3	W2-RC3
		4	W2-T4 + W2-DF4	W2-WT4	ELBOW: FSA-DWSW4 + FSELB9004 + FSBS4 TEE: FSA-SWDW4 + FSTT4	W2-RC4
Z-FLEX	SVE SERIES III ("Z-VENT III")	3	SVEDWCF03	2SVSWTEF03	ELBOW: 2SVSTEX0390 TEE: 2SVSTTF03	2SVSRCF03
		4	SVEDWCF04	2SVSWTEF04	ELBOW: 2SVVEWCF0490 + 2SVSTPF TEE: 2SVSTTF04	2SVSRCF04
METAL-FAB	CORR/GUARD	3	CGSWDS(3")	CGSWWPK(3")	ELBOW: CGSW90LTM(3") TEE: CGSWTTM(3")	CGSWC(3")
		4	CGSWDS(4")	CGSWWPK(4")	ELBOW: CGSW90LTM(4") TEE: CGSWTTM(4")	CGSWC(4")

**NOTES:**

- 1) See vent system manufacturer's literature for other part numbers that are required such as straight pipe, elbows, firestops and vent supports.
- 2) In addition to terminals shown, Crown coaxial terminals may be used in some cases. See Table 6.1 for applications and Crown part numbers.
- 3) All Heat Fab condensate traps shown may be installed in vertical or horizontal run.
- 4) Protech FSCD4 condensate trap may be installed in a vertical or horizontal run. All other Protech traps must be installed in a horizontal run only.
- 5) Heat Fab Saf-T Vent SC may not be used for horizontal coaxial venting - a separate air inlet pipe must be provided for horizontal direct vent systems. SC03HT or SC04HT adapters are used to adapt from SC pipe to terminal. Use of SC pipe in horizontal systems does allow for reduced clearances to combustibles in some applications. See Table 4.2.
- 6) Heat Fab SC03VT or SC04VT adapters are required on any vertical vent system using Saf-T Vent SC even when combustion air is obtained through a separate pipe or from the boiler room.
- 7) Metal-Fab CGSWDS condensate traps may only be installed in a horizontal run.

- 12) Vertical and horizontal sections of piping must be properly supported. See vent system manufacturer's instructions for more information.
- 13) Non-coaxial vent piping must be accessible for periodic inspection.
- 14) Fire stops and wall thimbles – Use fire stops where required by code or by the vent system manufacturer. Consult vent system manufacturer's literature for information on suitable fire stops.
- 15) Supports - Vertical and horizontal sections of vent pipe must be properly supported. See the Vent System assembly section of this manual for more information.

## B. Removing an Existing Boiler From a Common Chimney

Read this only if the CWD boiler is replacing an existing boiler that is being removed from a common chimney. This section does not apply to the installation of a CWD boiler.

In some cases, when an existing boiler is removed from a common chimney, the common venting system may be too large for the remaining appliances. At the time of removal of an existing boiler, the following steps shall be followed with each appliance remaining connected to the common venting system placed in operation, while the other appliances remaining connected to the common venting system are not in operation.

- (a) Seal any unused openings in the common venting system.
- (b) Visually inspect the venting system for proper size and horizontal pitch and determine there is no blockage or restriction, leakage, corrosion and other deficiencies which could cause an unsafe condition.
- (c) Insofar as practical, close all building doors and windows and all doors between the space in which all the appliances remaining connected to the common venting system are located and other spaces of the building. Turn on clothes dryers and any appliance not connected to the common venting system. Turn on any exhaust fans, such as range hoods and bathroom exhausts, so they will operate at maximum speed. Do not operate a summer exhaust fan. Close fireplace dampers.
- (d) Place in operation the appliance being inspected. Follow the lighting instructions. Adjust thermostat so the appliance will operate continuously.
- (e) Test for spillage at the draft hood relief opening after 5 minutes of main burner operation. Use the flame of a match or candle, or smoke from a cigarette, cigar, or pipe.
- (f) After it has been determined that each appliance remaining connected to the common venting system properly vents when tested as outlined above, return doors, windows, exhaust fans, fireplace dampers and any other gas-burning appliances to their previous condition of use.
- (g) Any improper operation of the common venting system should be corrected so the installation conforms with the National Fuel Gas Code, ANSI Z223.1. When resizing any portion of the common venting system, the common venting system should be resized to approach the minimum size as determined using the appropriate tables in Part 11 of the National Fuel Gas Code, ANSI Z223.1.



### WARNING

NEVER COMMON VENT A CWD BOILER WITH OTHER APPLIANCES

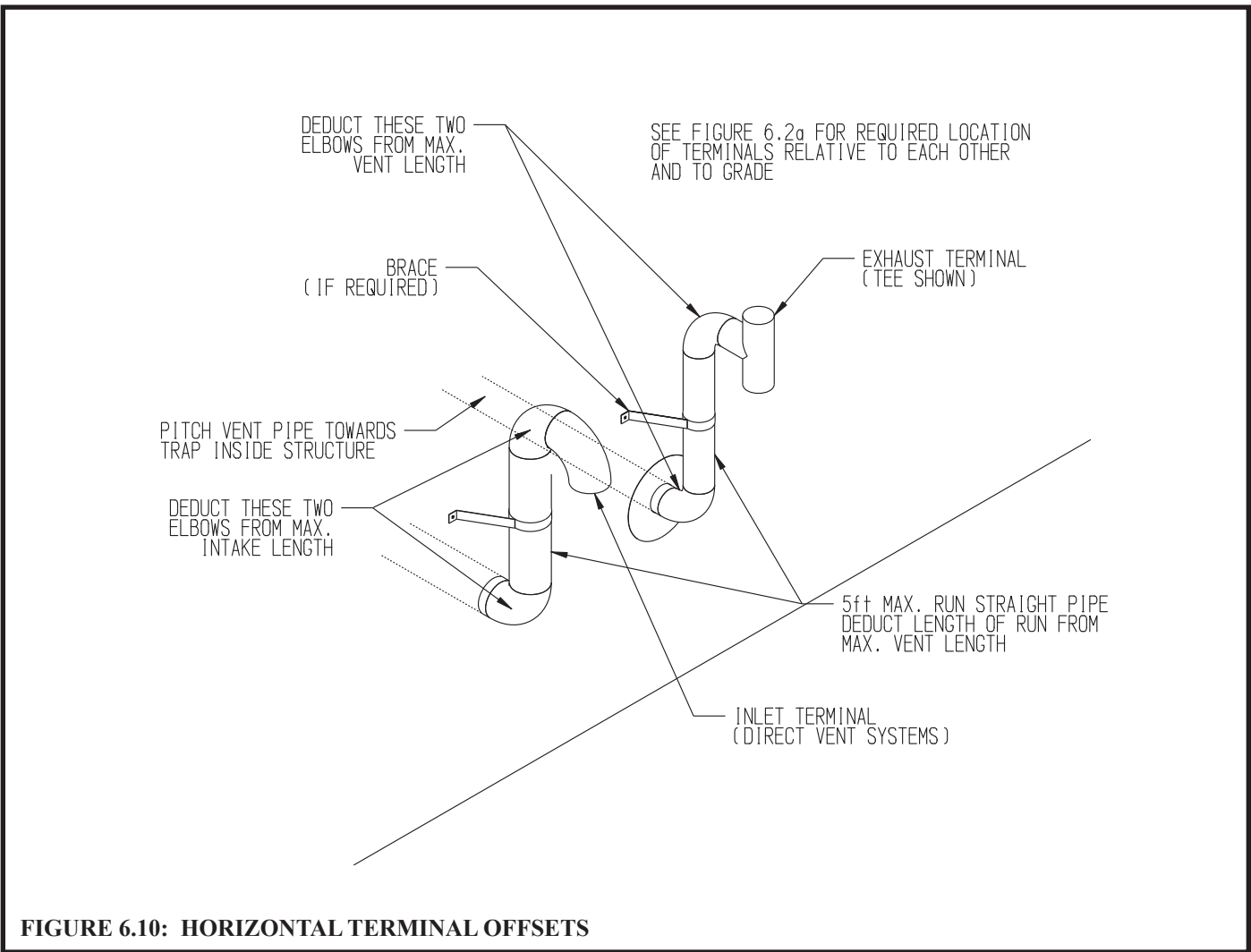
**TABLE 6.9a: VENT FITTING EQUIVALENT LENGTH**

VENT FITTING	EQUIVALENT LENGTH (ft)
3" 90 ELBOW	5.5
3" 45 ELBOW	4.0
HEAT FAB SC03E90 (3" COAXIAL 90 ELBOW)	5.5
HEAT FAB SC03E45 (3" COAXIAL 45 ELBOW)	4.0
4" 90 ELBOW	8.0
4" 45 ELBOW	4.5
HEAT FAB SC04E90 (4" COAXIAL 90 ELBOW)	8.0
HEAT FAB SC04E45 (4" COAXIAL 45 ELBOW)	4.5

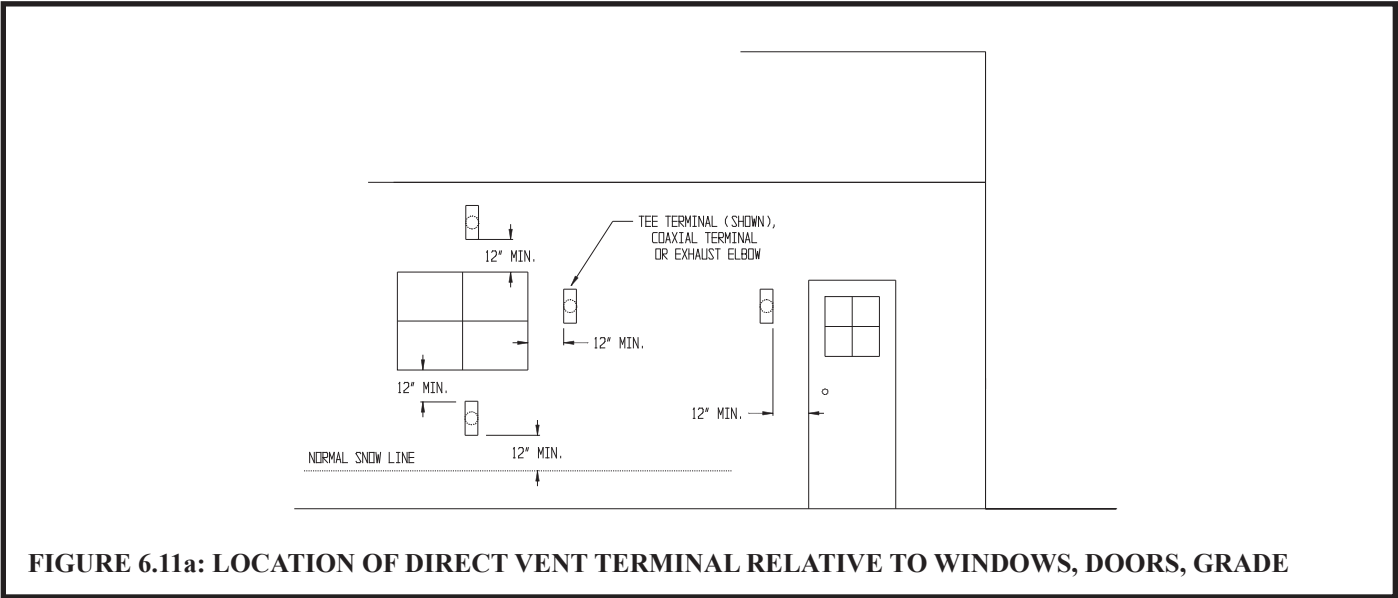
**TABLE 6.9b: AIR INTAKE FITTING EQUIVALENT LENGTH**

INTAKE FITTING	EQUIVALENT LENGTH (ft)
4" 90 ELBOW	8.0
4" 45 ELBOW	4.5
HEAT FAB SC03E90 (3" COAXIAL 90 ELBOW)	CONSULT CROWN
HEAT FAB SC03E45 (3" COAXIAL 45 ELBOW)	
HEAT FAB SC04E90 (4" COAXIAL 90 ELBOW)	
HEAT FAB SC04E45 (4" COAXIAL 45 ELBOW)	

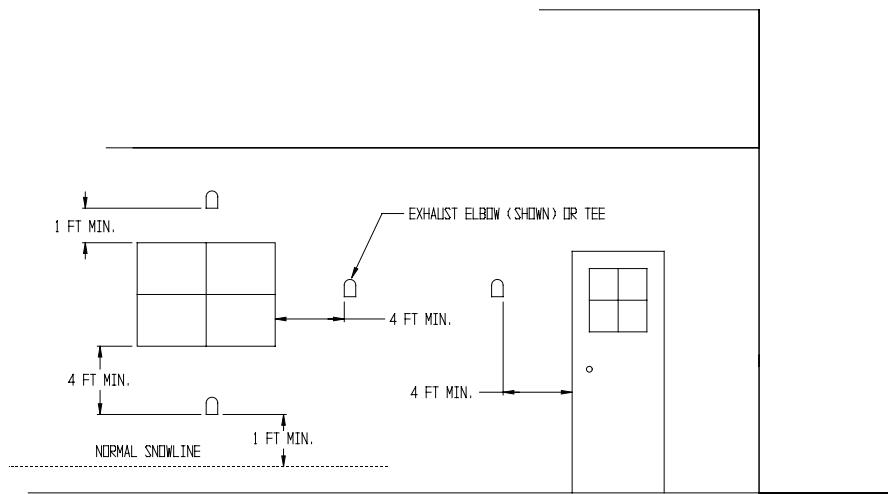




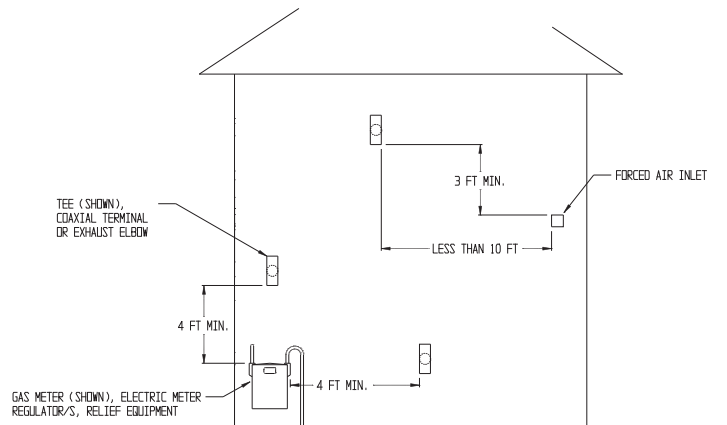
**FIGURE 6.10: HORIZONTAL TERMINAL OFFSETS**



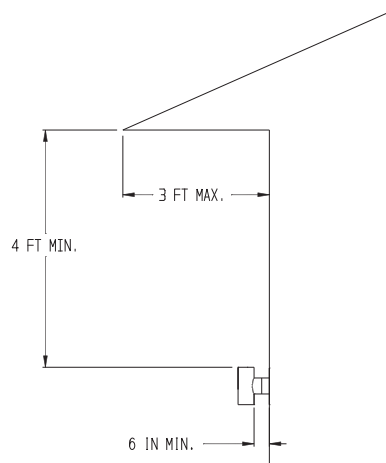
**FIGURE 6.11a: LOCATION OF DIRECT VENT TERMINAL RELATIVE TO WINDOWS, DOORS, GRADE**



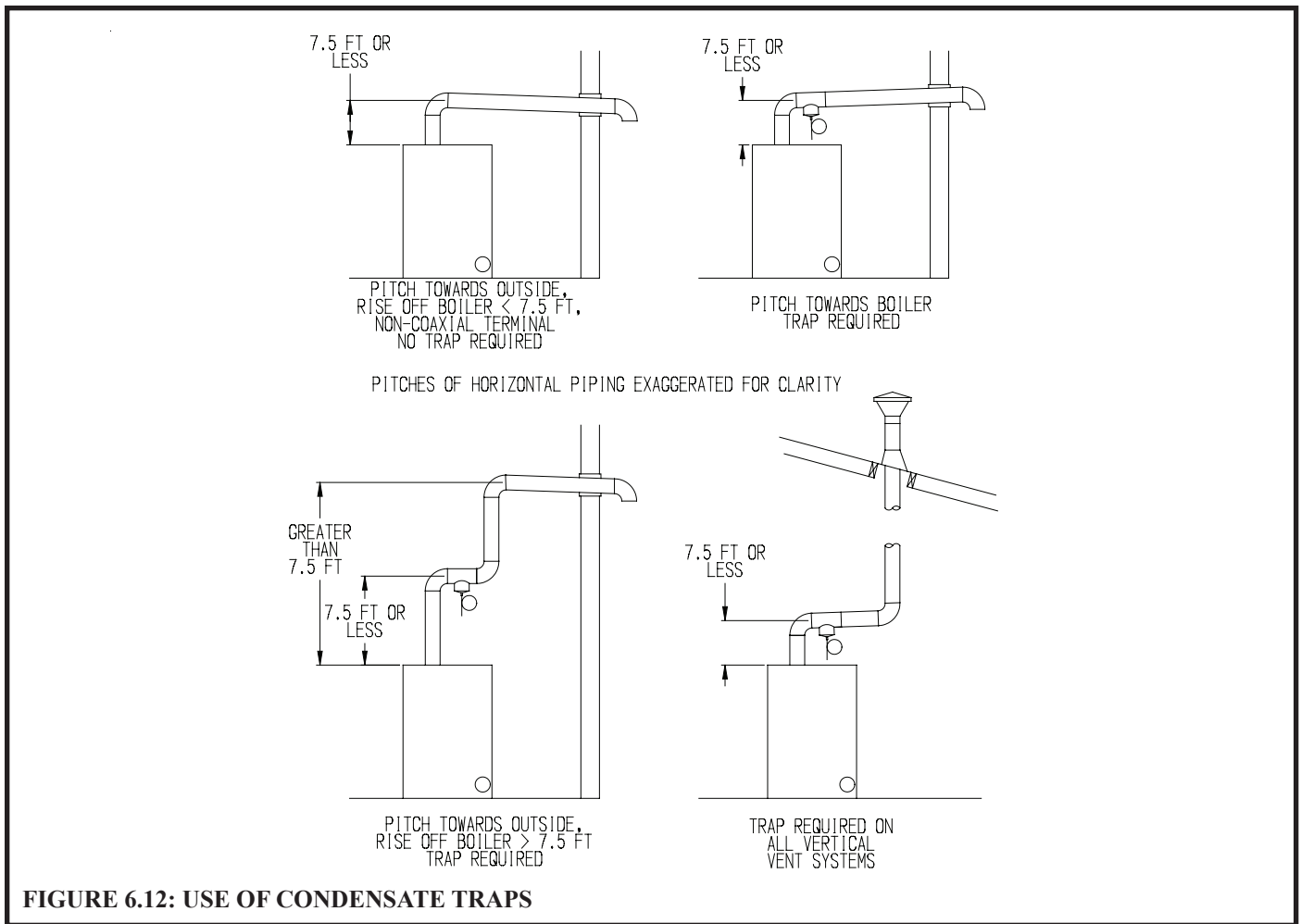
**FIGURE 6.11b: LOCATION OF DIRECT EXHAUST TERMINAL RELATIVE TO WINDOWS, DOORS, GRADE**



**FIGURE 6.11c: LOCATION OF VENT TERMINAL RELATIVE TO METERS AND FORCED AIR INLETS**



**FIGURE 6.11d: POSITIONING VENT TERMINAL UNDER OVERHANGS**



**FIGURE 6.12: USE OF CONDENSATE TRAPS**

### C. Vent / Intake System Assembly

1) General Assembly Notes:

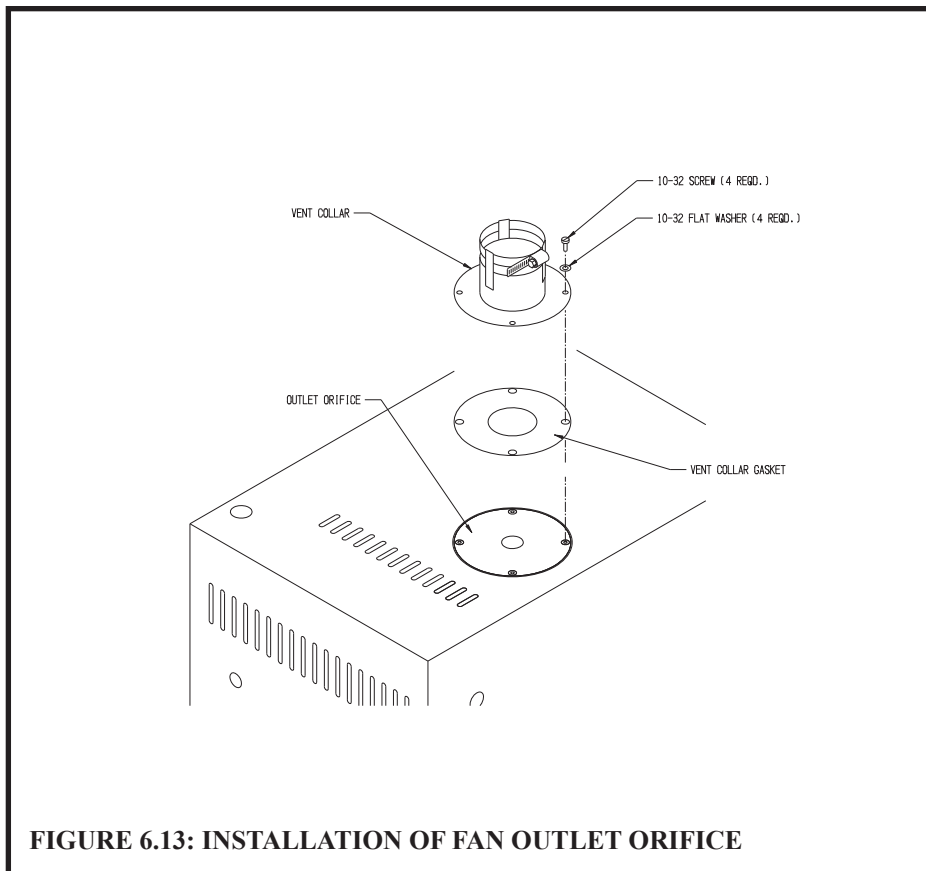
- a) Where the use of “silicone” is called for in the following instructions, use GE RTV 106 for the vent collar and coaxial terminal. Air inlet piping sections are sealed with any general-purpose silicone sealant such as GE RTV102. PVC air inlet piping sections are connected with PVC cement.
- b) Longitudinal welded seams should not be placed at the bottom of horizontal sections of exhaust pipe.
- c) Do not drill holes in vent pipe.
- d) Do not attempt to mix vent components of different vent system manufacturers.
- e) In some cases, there are differences between the vent system installation instructions in this manual and those in the vent system manufacturer’s manual. Where such differences exist, this manual takes precedence over the vent system manufacturer’s manual.

### CAUTION

Vent systems made by Heat Fab, Protech, and Z-Flex rely on gaskets for proper sealing. When these vent systems are used, take the following precautions:

- Make sure that gasket is in position and undamaged in the female end of the pipe.
- Make sure that both the male and female pipes are free of damage prior to assembly.
- Only cut vent pipe as permitted by the vent manufacturer in accordance with their instructions. When pipe is cut, cut end must be square and carefully deburred prior to assembly.

- 2) Vent Collar Installation – The vent collar is shipped loose in the accessory bag along with a collar gasket and four 10-32 mounting screws. Mount the collar and orifice as shown in Figure 6.13. If desired, the first piece of exhaust pipe can be connected to the collar before mounting the collar on the boiler.

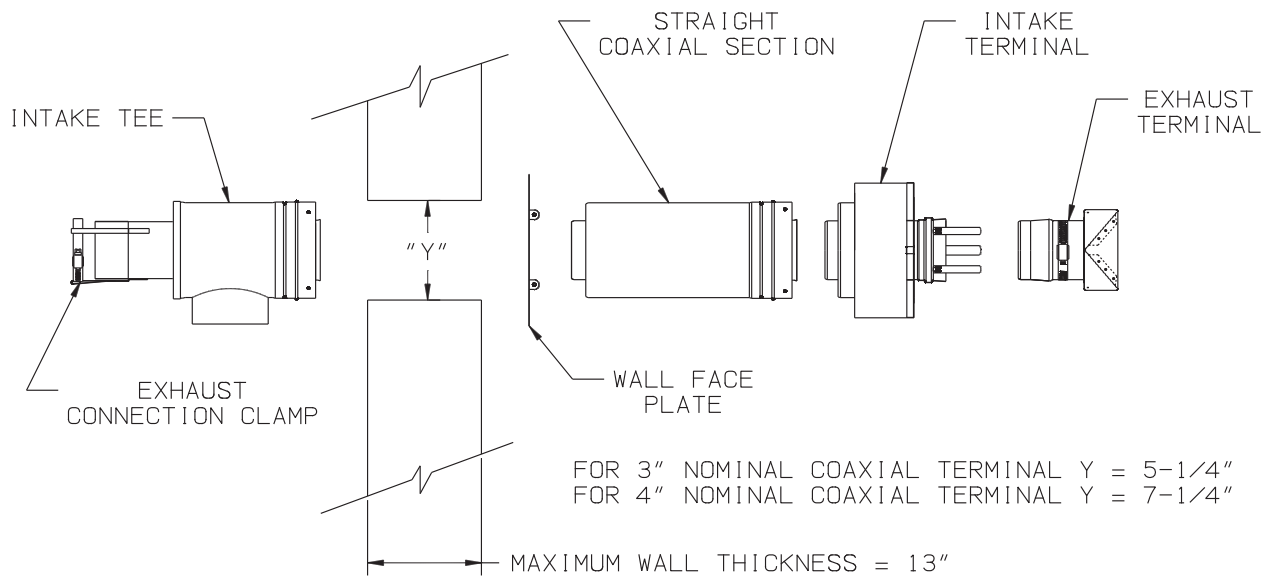


- 3) Optional Coaxial Terminal Installation – If the optional coaxial terminal is used, it should be installed in the wall before vent assembly is started. Install the terminal in accordance with the following procedure (Figures 6.14a & 6.14b):

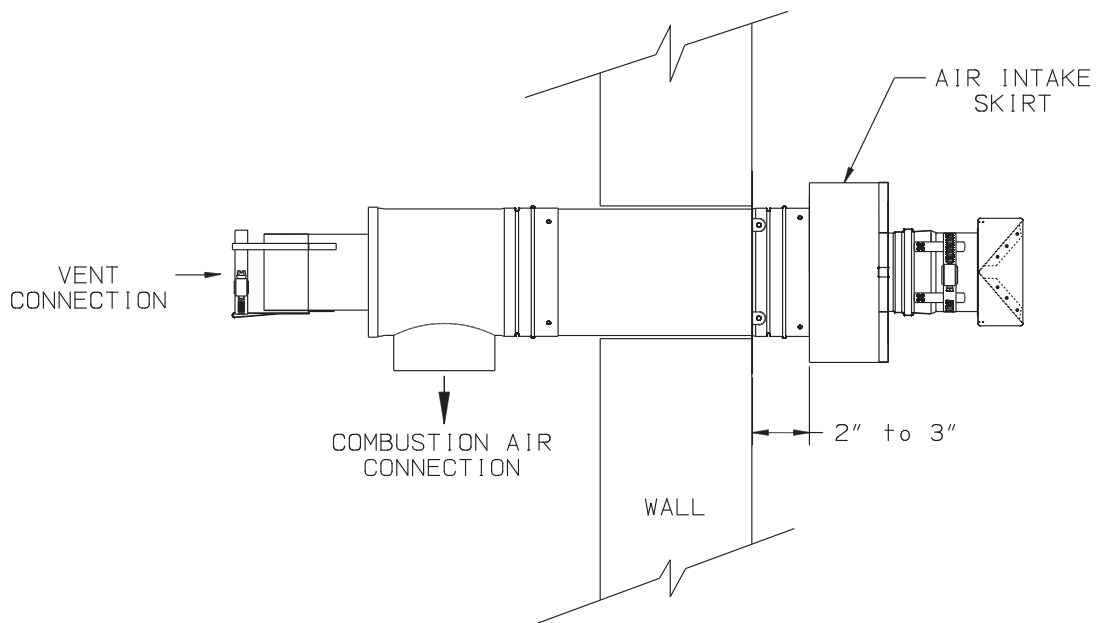
#### NOTE

- **Coaxial portion of inside terminal section may be installed in direct contact with combustible construction.**
- **Maximum wall thickness through which this terminal can be installed is 10”**

- a) Position the wall face plate on the outside wall in the desired terminal location. Verify that this location will permit the terminal, and connected venting, to clear any obstructions on the inside of the wall with the appropriate clearances. Mark the location of the round opening on the wall.
- b) For 3” terminals, cut a 5 1/4” Diameter hole through the wall at this location. For 4” terminals, cut a 7 1/4” opening.
- c) Attach the mounting plate to the outside wall with suitable fasteners.
- d) Attach the intake terminal to the straight coaxial section. To do this, clean the male and female ends of the inner pipes with an alcohol pad. Lubricate the gasket in the female end of the straight section with a package of the silicone lubricant provided and then push the intake terminal firmly onto the straight section until the intake terminal makes contact with the bead on the straight section. Secure the two fittings together with the self-drilling screws provided. Use a low torque setting to install these screws so as not to strip out the holes.
- e) Pass the assembled intake terminal and straight section through the wall from the outside. Bend the four Tabs in the wall face plate towards the outside when doing this. Do not attach the pipe to the plate yet.
- f) Adjust the position of the terminal in the wall so that the edge of the intake skirt is 2-3” from the wall plate (Figure 6.14b). Also verify that the terminal is pitched in the same direction as the rest of the vent system.
- g) Attach the intake/straight section to the wall face plate using the self drilling screws provided.
- h) Loosen the hose clamp on the end of the exhaust terminal. Mount the exhaust terminal onto the intake terminal with the “V” horizontal (flue gas openings on top and bottom) as shown in Figure 6.14b. Slip the hose clamp over the “fingers” on the intake terminal and tighten the clamp.
- i) Seal all exposed exterior joints, including the joint between the wall face plate and the wall and between the wall face plate and the straight section with an exterior grade silicone sealant.



**FIGURE 6.14a: CROWN COAXIAL TERMINAL EXPLODED VIEW**



**FIGURE 6.14b: CROWN COAXIAL TERMINAL ASSEMBLY**

- j) Attach the intake tee to the end of the straight section protruding from the inside wall. Use the procedure described in (d) to clean and assemble these parts.
- k) If the inside terminal section is not supported by the wall through which it passes, install additional supports or bracing to support the terminal. Bracing in contact with the coaxial section of the terminal may be combustible.

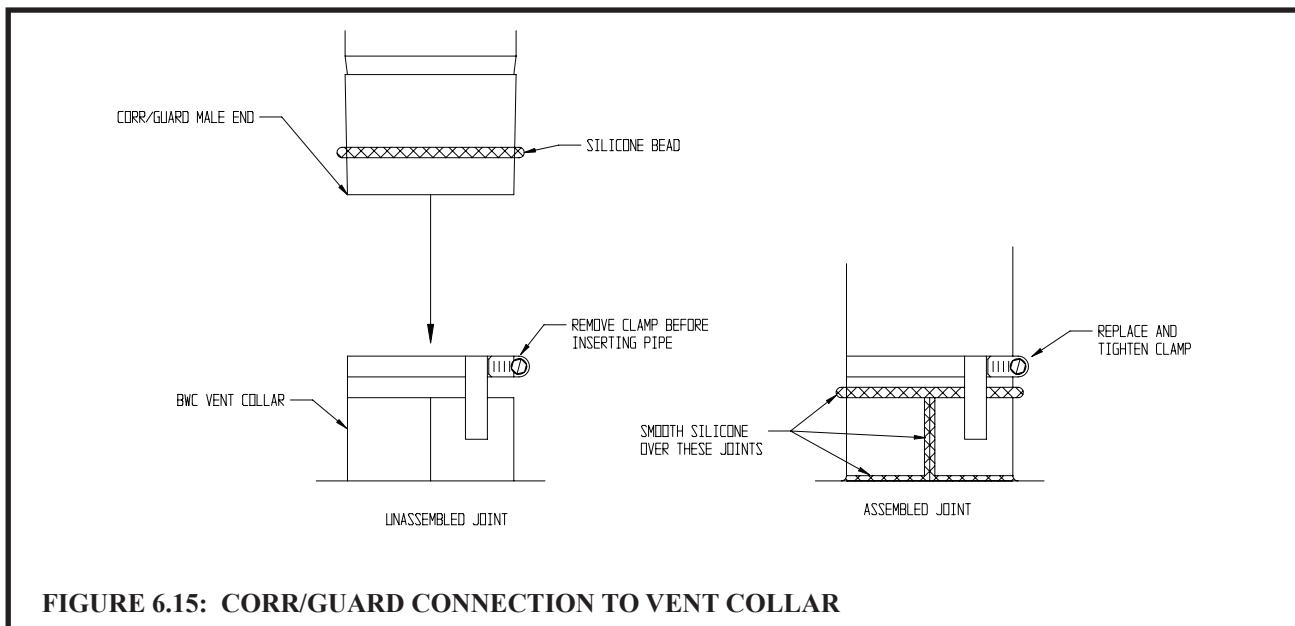
4) Assembly of Metal-Fab Corr/Guard Vent System:

a) Corr/Guard General Notes:

- Do not cut Corr/Guard vent components.
- Refer to Corr/Guard installation instructions for proper methods of support.
- Orient Corr/Guard components so that the males ends of all fittings point in the direction of the boiler.

- b) Start assembly of the vent system at the boiler. Remove the hose clamp shipped on the BWC vent collar. Bend the three hose clamp tabs on this collar outward slightly.
- c) Clean the exterior of the male end of the first piece of pipe and the inside of the vent collar on the boiler. Remove dirt, grease, and moisture from the surfaces to be sealed. Dry surfaces or allow to dry thoroughly.
- d) On the male end of the pipe, apply a 1/4" wide bead of silicone approximately 1/2" from the end of the pipe (Fig 6.15).
- e) Insert the male end of the pipe into the boiler vent collar until it bottoms out.
- f) Apply an additional bead of silicone over the outside of the joint and smooth out.
- g) Replace and tighten the clamp on the vent collar.
- h) Assemble remaining Corr/Guard components in accordance with the Corr/Guard installation instructions.
- i) Allow the silicone to cure per the silicone manufacturer's instructions before operating the boiler.

Note: To join Corr/Guard to a Crown coaxial terminal, leave the Corr/Guard gasket in place. Apply a 1/4" bead of silicone to the terminal connection about 1/4" from its end. Slip the Corr/Guard female end over the terminal end so that there is an overlap of approximately 1 3/4 inches. Apply and smooth silicone over the outside of the joint including the tabs in the female end of the Corr/Guard pipe. Tighten the terminal hose clamp to mechanically lock the pipe onto the terminal.

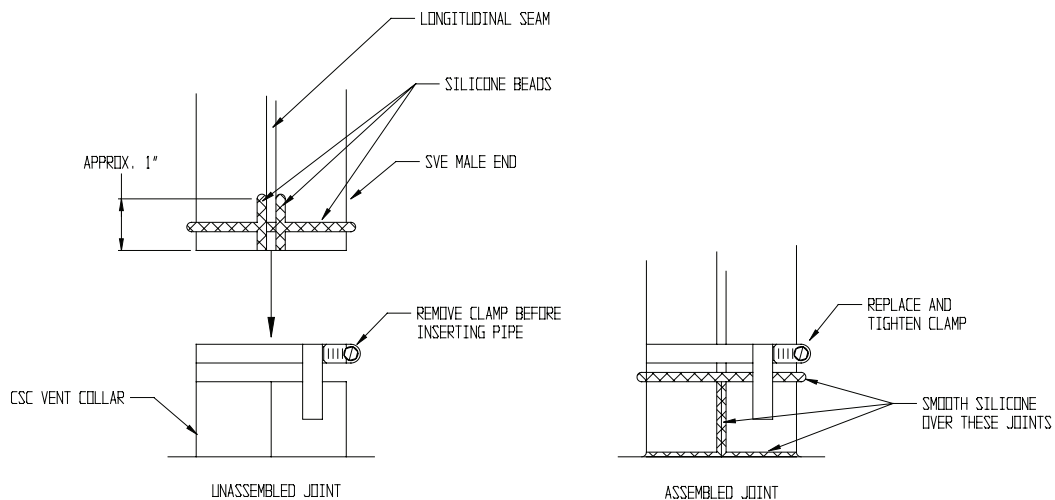


**FIGURE 6.15: CORR/GUARD CONNECTION TO VENT COLLAR**

5) Assembly of Z-Flex Z-Vent III:

a) General Notes:

- Non-expanded ends of SVE Series III piping sections may be cut using aviation snips or a 24 thread per inch hacksaw. File or sand the cut end smooth before assembling. Expanded ends may be cut to adapt the SVE series III to the vent collar or Crown coaxial terminal. See the following instructions.
  - Support horizontal piping sections at intervals of 48" or less.
  - Vertical venting systems must be supported by at least one Z-Flex fire stop. An additional vertical support is required after any offset and as required by the Z-Vent III installation instructions.
- b) Start assembly of the vent system at the boiler. Remove the hose clamp shipped on the CWD vent collar. Bend the three hose clamp tabs on this collar outward slightly.
- c) Clean the exterior of the male end of the first piece of pipe and the inside of the vent collar on the boiler. Remove dirt, grease, and moisture from the surfaces to be sealed. Dry surfaces or allow to dry thoroughly.
- d) On the male end of the pipe, apply a 1/4" wide bead of high temperature silicone approximately 1/2 inch from the male end of the pipe. Apply 1/4" beads of silicone along both sides of the longitudinal seam (Fig. 6.16).
- e) Insert the male end of the pipe into the boiler vent collar until it bottoms out.
- f) Apply an additional bead of silicone over the outside of the joint and smooth out. Also apply silicone over the seams in the collar (Fig 6.16).
- g) Replace and tighten the clamp on the vent collar.
- h) The female end of each Z-Vent III component has a silicone sealing gasket. Examine all vent components to insure that the gasket integrity has remained during shipping. Gaskets must be in the proper position or flue gas could leak resulting in carbon monoxide poisoning.
- i) Align the second piece of pipe with the first and push them together as far as they will go, but not less than 1 3/4".
- j) Tighten gear clamp to a minimum torque of 40 in-lbs and a maximum of 50 in-lbs.
- k) Repeat Steps (h) – (j) for the remaining Z-Vent III components. If a termination elbow is used, use this procedure to complete the vent system.
- l) If a termination elbow or tee is used, a locking band or gear clamp must be used at either side of the wall penetration to prevent shifting of the vent system in and out of the wall. This applies to both combustible and non-combustible walls.
- m) To join Z-Vent III to a Crown coaxial terminal, a male end must be present at the end of the piping to be joined to the terminal. It will therefore be necessary to cut off the expanded end of the pipe before it can be joined to the terminal. This male end of the pipe must be inserted into the terminal connection with at least a 1" overlap. It may be necessary to crimp the end of the vent pipe before it can be inserted into the terminal. Apply silicone to the male end of the pipe as in (d) above, insert into the terminal, and apply an additional bead of silicone over the outside of the joint. Smooth out the excess silicone and tighten the hose clamp on the terminal.
- n) Allow the silicone to cure per the silicone manufacturer's instructions before operating the boiler.



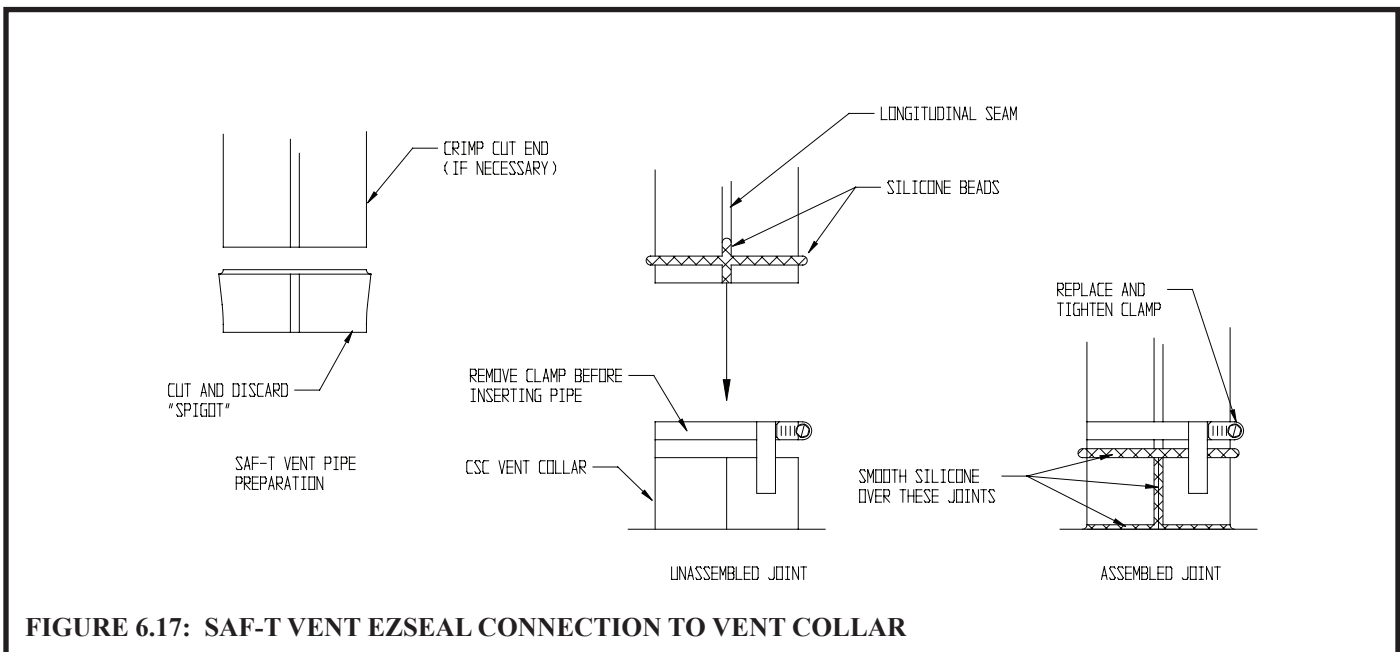
**FIGURE 6.16: Z-VENT III CONNECTION TO VENT COLLAR**

6) Assembly of Heat Fab Saf-T Vent EZ Seal:

a) Saf-T Vent General Notes:

These instructions cover the installation of Saf-T Vent EZ Seal. Saf-T Vent EZ Seal piping has integral gaskets installed in the female ends of the pipe which seal the joints.

- In general, Saf-T Vent pipe sections may not be cut. Exceptions to this are the Saf-T Vent slip connector and connections to the boiler vent collar and Crown coaxial terminal. In these cases, use a sharp pair of aviation snips, an abrasive cut-off, or a plasma cutter. See the Saf-T Vent instructions for information on cutting the slip connector.
  - Orient Saf-T Vent components so that the arrows on the piping labels are in the direction of flue gas flow.
  - Support horizontal piping sections at intervals of 6 feet or less.
  - Vertical venting systems must be supported by at least one Heat Fab support. An additional vertical support is required after any offset.
- b) Connection to Boiler – Start assembly of the vent system at the boiler. Remove the hose clamp shipped on the CWD vent collar. Bend the three hose clamp tabs on this collar outward slightly. Cut the male “spigot” off of the first piece of pipe (Fig 6.17). If necessary, crimp the cut end of the pipe so that it can be inserted at least 1” into the collar. Clean the exterior of the male end of the first piece of pipe and the inside of the vent collar on the boiler with an alcohol pad. On the male end of the pipe, apply a ¼” wide bead of high temperature silicone approximately ½ inch from the male end of the pipe. Also apply a ¼” bead of silicone along the first 2 ½” of the longitudinal weld. Insert the male end of the pipe into the boiler vent collar until it bottoms out. Apply an additional bead of silicone over the outside of the joint and smooth out (Fig 6.17). Apply silicone over the seams in the vent collar. Replace and tighten the clamp on the vent collar.
- c) Assembly of Saf-T Vent EZ Seal Vent Components - Clean the male end of the next piece of pipe with an alcohol pad and make sure that it is free of burrs. Check the female end of the first piece of pipe to make sure that the gasket is in place and is undamaged. Using a slight twisting motion, insert the male end of the second fitting into the female end of the first fitting, taking care not to dislodge or cut the factory gasket. In extremely arid conditions, it may be easier to assemble these fittings if the gasket is moistened with water prior to assembly. Bend the locking tabs over the locking ring on the adjacent piece of pipe. Repeat these steps for the remaining Saf-T-Vent components. If a termination elbow is used, use this procedure to complete the exhaust system.
- d) Connection of Saf-T Vent to Crown coaxial terminal - Cut the locking tabs off of the female end of the Saf-T Vent pipe to be joined to the co-axial terminal. Apply a ¼” bead of silicone around the terminal connection about ¼” from the end. Slip the Saf-T Vent pipe over the terminal and apply a second bead of silicone over the joint. Silicone must be applied even though there is a gasket on the female end of the pipe. Smooth the excess silicone over the joint, making sure that there are no visible voids in the silicone. Tighten the terminal clamp. Allow the silicone to cure per the silicone manufacturer’s instructions before operating the boiler.



**FIGURE 6.17: SAF-T VENT EZSEAL CONNECTION TO VENT COLLAR**



- 7) Assembly of Heat Fab Saf-T Vent SC - On CWD Boiler installations where Saf-T Vent SC is used, some Saf-T Vent EZ Seal (single wall pipe) will always be required between the boiler and the Saf-T Vent SC. Install this pipe as described above. On all systems except vertical coaxial systems (Options 12, 13), the following Heat Fab adapters will be needed to adapt from Saf-T Vent EZ Seal to Saf-T Vent SC:

Vent Size	Heat Fab Part Number
3"	SC03ADEZ
4"	SC04ADEZ

On vertical coaxial vent systems employing Saf-T Vent SC, the transition from Saf-T Vent to Saf-T Vent SC is made with one of the following Air Intake Tees:

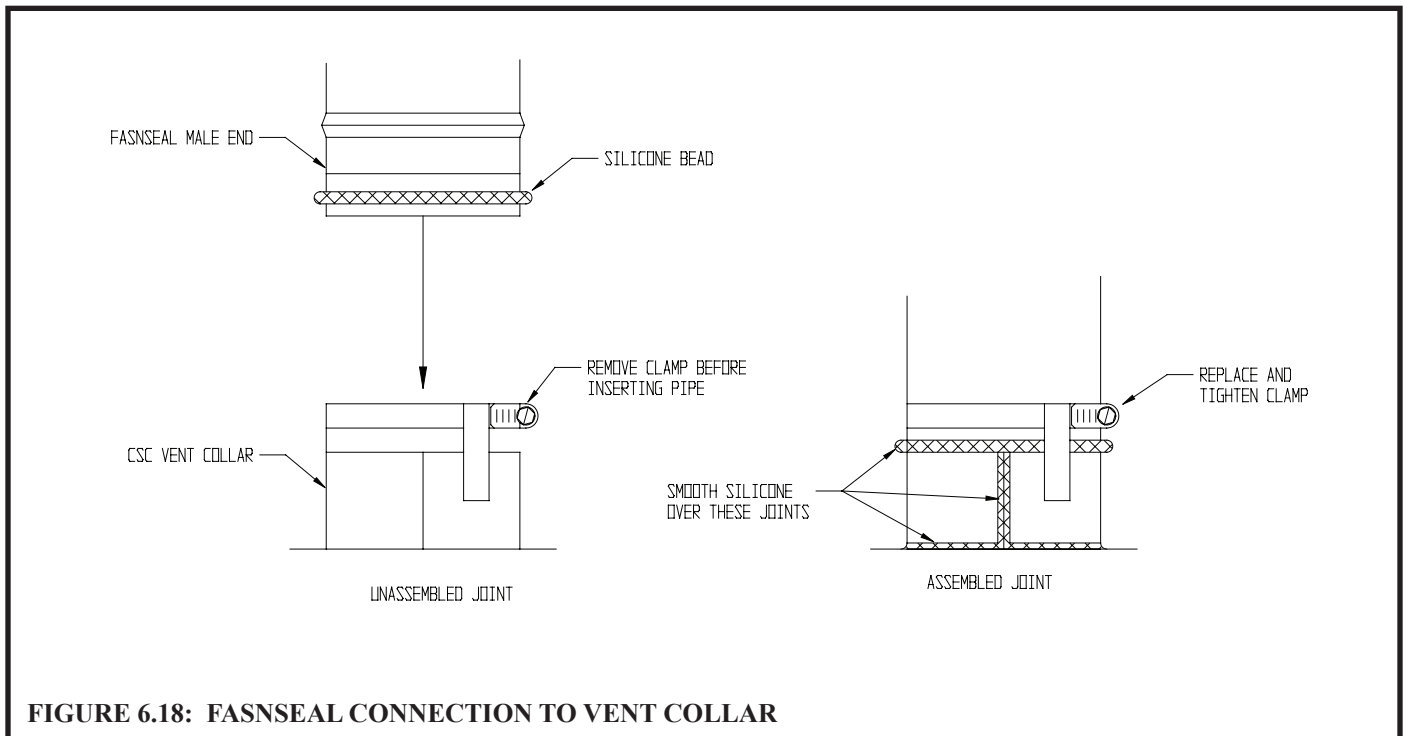
Vent Size	Heat Fab Part Number
3"	SC03TAD4
4"	SC04TAD4

Assemble the Saf-T Vent EZ Seal to the boiler and the adapter as described in (6) above. Proceed as follows to assemble the Saf-T Vent SC:

- Clean both ends of the inner pipes to be joined with an alcohol pad. This will remove any foreign matter which may effect the integrity of the seal. Insert the male end of the first piece of pipe into the adaptor. In extremely dry conditions it may be helpful to moisten the gasket with clean water prior to assembly.
- Push the first Saf-T Vent SC section into the adaptor until the outer jacket has made contact with the snap ring located inside the female end of the adaptor. When fully assembled the outer female end will overlap the male end by 1".
- Use the three self tapping screws provided with the vent to attach the first piece of pipe to the adaptor. No pre drilling is required. If using a variable torque screw gun, use the low torque setting to install the screws so as not to strip out the holes. If a hole does become stripped due to over tightening, a larger (1/2" long max.) screw or short pop rivet may be used.
- Seal all the joints in the outer jacket with foil tape or exterior grade silicone sealant.
- Repeat steps (a - d) to assemble the remaining sections of Saf-T Vent SC.
- Support the Saf-T Vent SC as called for in Heat Fab's installation instructions. Also make sure that fire stops are provided as called for in Heat Fab's instructions and local codes.
- After the Saf-T Vent SC exits the building, one of the following adaptors will be needed to install the terminal:

Vent Size	Heat Fab Part Number
3"	5300CI
4"	5400CI

On vertical coaxial vent systems (Vent Options 12, 13) this adaptor also acts as the combustion air intake terminal. In other installations, the openings in this adaptor provide ventilation between the inner and outer walls.



**FIGURE 6.18: FASNSEAL CONNECTION TO VENT COLLAR**

8) Assembly of Protech FasNSeal

a) FasNSeal General Notes:

- Do not cut 4" FasNSeal pipe. Consult FasNSeal instructions for method of cutting other 3" pipe.
- Orient FasNSeal vent components so that the arrows on the piping labels are in the direction of flue gas flow.
- Support horizontal piping sections at intervals of 6 feet or less.
- Vertical venting systems must be supported by at least one FasNSeal support. An additional vertical support is required after any offset.

- a) Remove the hose clamp shipped on the CWD vent collar. Bend the three hose clamp tabs on this collar outward slightly. Clean the exterior of the male end of the first piece of pipe and the inside of the vent collar on the boiler. Remove dirt, grease, and moisture from the surfaces to be sealed. Dry surfaces or allow to dry thoroughly. On the male end of the pipe, apply a 1/4" wide bead of high temperature silicone approximately 1/4 inch from the male end of the pipe. Insert the male end of the pipe into the boiler vent collar until it bottoms out. Apply an additional bead of silicone over the outside of the joint and the seams on the vent collar and smooth out (Fig 6.18). Replace and tighten the clamp on the vent collar.
- b) All other joints in the FasNSeal venting system rely on a gasket in the female end of the pipe for a proper seal.
- c) Align the longitudinal seam of both pipes. Insert the male end of the second pipe into the female end of the first pipe until the bead on the male end contacts the flare on the female end (Fig. 6.18).
- d) Tighten the locking band with a nut driver.
- e) Repeat (c) and (d) for the remaining FasNSeal components. If a termination elbow is used, use this procedure to complete the exhaust system.
- f) To join FasNSeal to a Crown coaxial terminal, remove the hose clamp from the female FasNSeal end to be joined to the terminal. Leave the FasNSeal gasket in place. Apply a 1/4" bead of silicone to the terminal connection about 1/4" from its end. Slip the FasNSeal female end over the terminal end so that there is an overlap of 1 3/4 inches. Apply and smooth silicone over the outside of the joint including the rectangular hose clamp opening in the FasNSeal pipe. Tighten the terminal hose clamp to mechanically lock the pipe onto the terminal.
- g) Allow the silicone to cure per the silicone manufacturer's instructions before operating the boiler.

9) Assembly of Protech FasNSeal W2 - On CWD Boiler installations where Protech FasNSeal W2 is used, some Protech FasNSeal (single wall pipe) will always be required between the boiler and the FasNSeal W2. Install this pipe as described above. On all systems, the following components will be needed to adapt from Protech FasNSeal to FasNSeal W2:

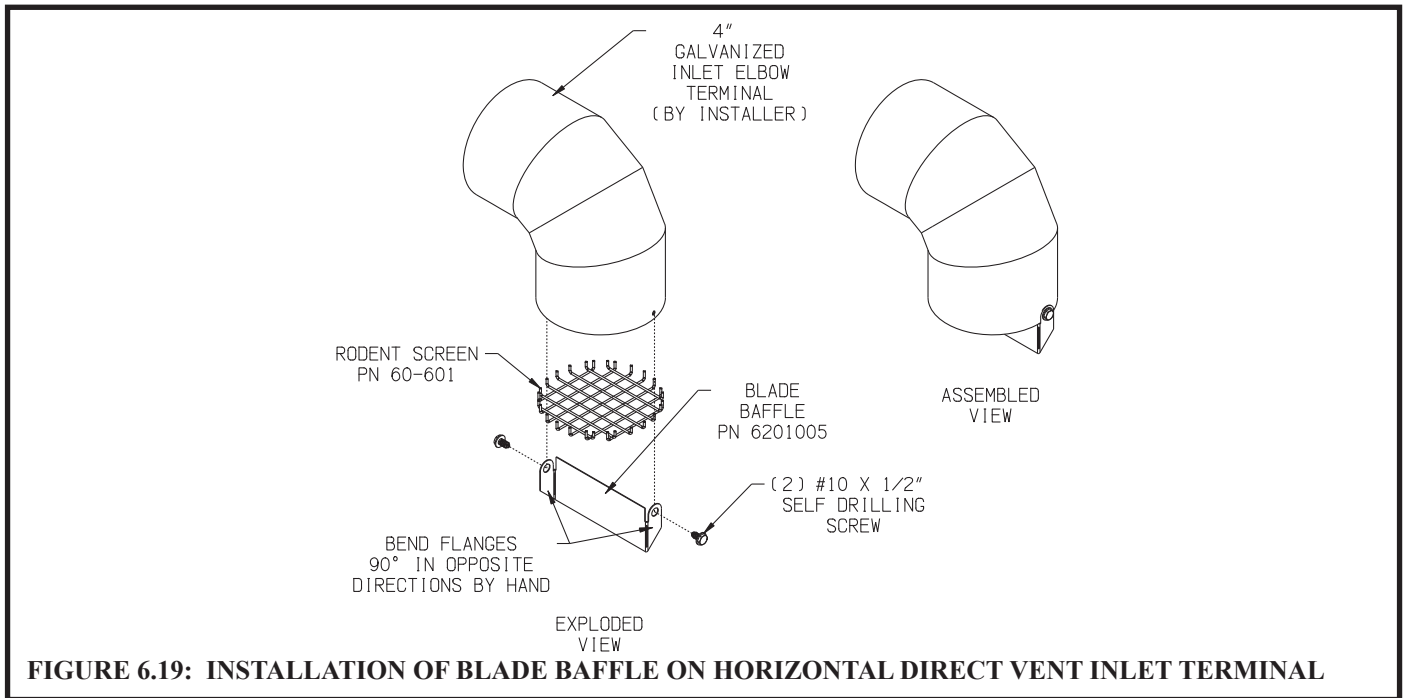
<u>Vent Size</u>	<u>Protech Part Number</u>
3"	FSA-SWDW3
4"	FAS-SWDW4

Follow the joint connection instructions provided with the FasNseal W2. In vertical vent systems, terminate the vent system with the cap called for FasNSeal W2 in Table 6.8. In horizontal vent systems one of the following adapters will be required between the FasNSeal W2 and the terminal:

<u>Vent Size</u>	<u>Protech Part Number</u>
3"	FSA-DWSW3
4"	FAS-DWSW4

10) Assembly of the air intake system:

- a) Assemble the air intake system using either galvanized or PVC pipe.
- b) If PVC piping is used, use PVC cement to assemble the PVC intake system components.
- c) If galvanized piping is used, use at least two sheet metal screws per joint. Seal the outside of all joints.
- d) A 4" galvanized smoke pipe will fit inside the inlet collar on the CWD boiler. Depending upon the exact OD of the pipe used, it may be necessary to crimp this pipe. Secure with a single #10 sheet metal screw through the hole in the inlet collar and seal the outside of the joint with silicone. If PVC is used for the intake system, use a short piece of 4" galvanized pipe to connect the PVC to the boiler. Silicone the outside of the joint between the PVC and galvanized pipe.
- e) Either PVC or galvanized pipe will fit over the combustion air connection on the Crown coaxial terminal. Secure the pipe to the terminal with at least two #10 sheet metal screws. Seal the outside of the joint between the inlet pipe and the coaxial terminal.
- f) Two 90-degree elbows may be used to make the 180-degree air intake termination elbow used on vertical direct vent installations.
- g) For horizontal direct vent installations install the blade baffle in the orientation shown in Figure 6.19 with two #10 x 1/2" self drilling sheet metal screws in the inlet elbow terminal.



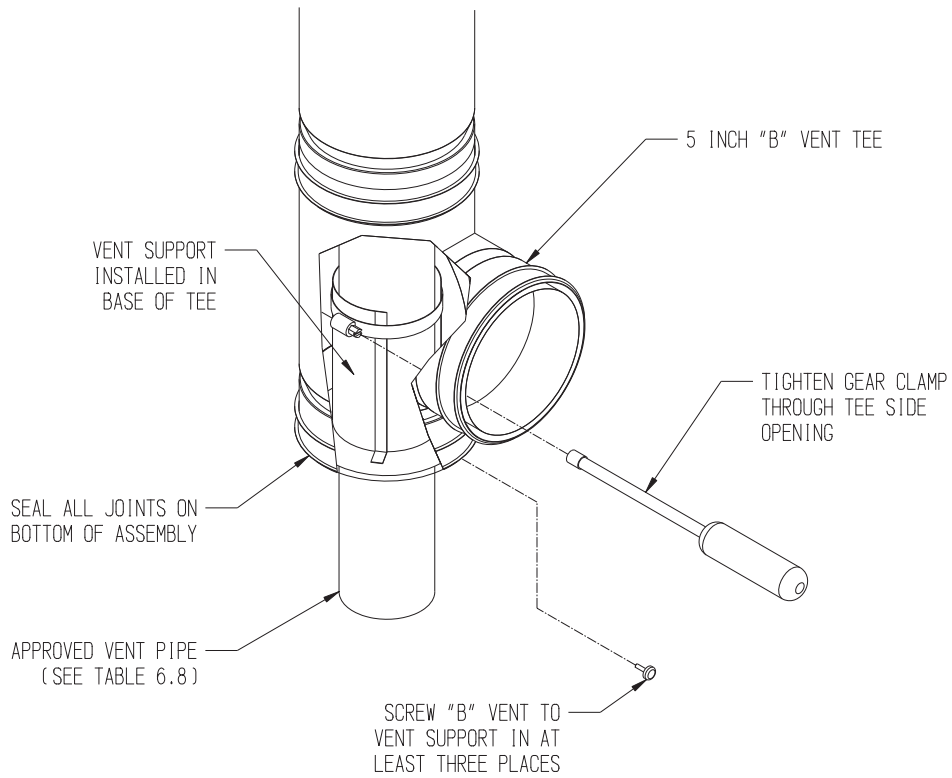
11) Assembly of Vertical Coaxial Vent System Using Crown #500005 Coaxial Vent Kit (Vent Option #11)

- a) Start by installing the “B” vent piping. Install and assemble this piping in accordance with the “B” vent manufacturer’s instructions. Seal the joints between sections of “B” vent with GE RTV 106 or Dow 732 RTV sealant. Consult the “B” vent manufacturer’s instructions for the clearance to combustibles (typically 1”) as well as for fire stop and support requirements.
 

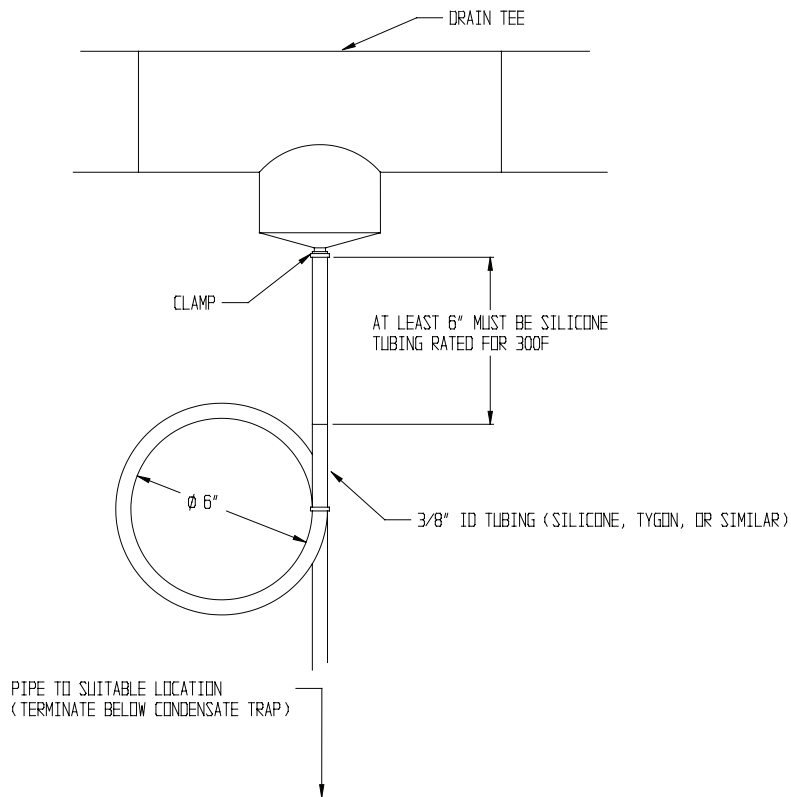
Install a 5” “B” vent Tee on the bottom of the run of “B” vent as shown in Figure 6.6. Extend the run of “B” vent far enough above the roof so that the bottom of the air intake hood will be at least one foot above the normal snow line that can be expected on the roof. Seal the roof penetration with a “B” vent roof flashing and storm collar in accordance with the “B” vent manufacturer’s instructions.
- b) Assemble the vent piping that is to be run inside the “B” vent and drop it through the “B” vent. Join and seal the vent piping in accordance with the instructions 4, 5,6 or 8 above. Use the longest sections of vent piping possible so as to minimize the number of joints inside the “B” vent. Temporarily support the vertical section of vent pipe from underneath so that the top of the vent pipe is at the correct height (Figure 6.6).
- c) Slip the Crown concentric air intake hood over the vent pipe and seat it on the “B” vent. Secure the concentric air intake hood to the “B” vent with at least three sheet metal screws. Install a storm collar compatible with the vent system over the vent pipe. Secure and seal it in accordance with the vent manufacturer’s instructions. Note: this collar provides a watertight seal between the vent piping and the concentric air intake hood and also supports the vent piping. Once the storm collar is installed, remove the temporary vent support. Install a compatible rain cap on the top of the vent system (Table 6.8).
- d) Slip the Crown vent support over the vent pipe protruding from the bottom of the “B” vent. Orient the vent support so that it will be possible to tighten the gear clamp by reaching through the side opening in the “B” vent Tee (Figure 6.20). Attach the vent support to the “B” vent Tee with at least three sheet metal screws. Tighten the gear clamp. Seal all joints in between the vent support, the vent pipe, and the “B” vent.
- e) Install the vent piping between the boiler and the vertical section of “B” vent already installed. Observe the clearance and support requirements in the installation manual.
- f) Install a 5 x 4 single wall reducer in the side connection of the “B” vent Tee. Install 4” galvanized or PVC piping between this reducer and the combustion air intake on the boiler. Seal all joints in the air intake piping.

12) Condensate Traps:

- a) Trap should have the basic configuration shown in Figure 6.21. All tubing is 3/8 I.D.
- b) All drain tubing must be acid resistant.
- c) At least the first 6 inches of tubing must be silicone with a 300F temperature rating.
- d) Pipe condensate to a drain or other suitable location. Make sure that condensate disposal method is in accordance with local regulations. Ensure condensate is not subjected to freezing temperatures.



**FIGURE 6.20: INSTALLATION OF VENT SUPPORT PROVIDED IN CROWN #500005 VERT. COAXIAL VENT KIT**



**FIGURE 6.21: CONDENSATE TRAP/DRAIN DETAIL**

13) Rodent Screens:

- a) A rodent screen is provided with the CWD boiler. On direct exhaust boilers, this screen is installed in the air inlet collar on the boiler and held in place with screws or RTV sealant.
- b) The Crown coaxial terminal has integral inlet and exhaust rodent screens. The rodent screen supplied with the boiler is not used when the boiler is installed with the coaxial terminal.
- c) In horizontal direct vent installations using termination elbows or tees, the rodent screen provided is mounted in the air inlet elbow. A second screen is required for the exhaust elbow. This second screen can be any one of the following items:
  - A rodent screen provided by the vent system manufacturer.
  - A second Crown rodent screen (Crown #60-601).
  - A rodent screen made of stainless steel screen having a 1/2" (2 x 2) or greater mesh.
- d) In vertical direct vent or direct exhaust systems, no rodent screen is required on the exhaust terminal. The rodent screen is installed either on the 180-degree inlet elbow (direct vent installations) or on the boiler inlet collar (direct exhaust installations).

## VII Gas Piping

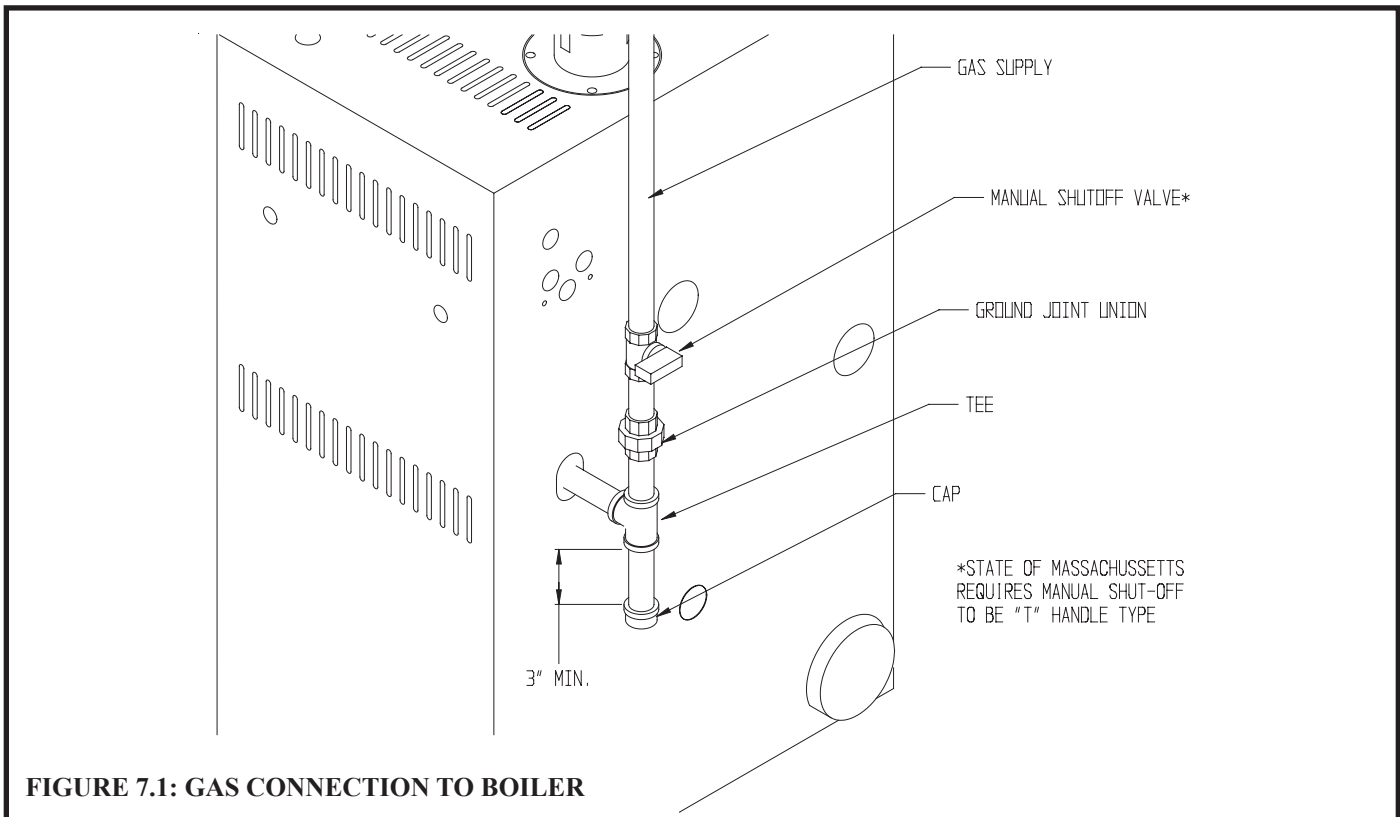
### WARNING

- SHUT OFF GAS SUPPLY BEFORE SERVICING THE BOILER.
- ALL GAS PIPING MUST BE GAS TIGHT. USE GAS RATED THREAD COMPOUND ON ALL THREADED JOINTS TO AVOID LEAKS, WHICH MAY RESULT IN FIRE OR EXPLOSION.
- SIZE GAS PIPING, REGULATORS, VALVES AND METERS SO AS TO PROVIDE AN ADEQUATE GAS FLOW AND PRESSURE TO THE BOILER DURING OPERATION. FAILURE TO DO SO MAY CAUSE POOR COMBUSTION, NOISE, INJURY OR DEATH.

Gas piping to the boiler must be sized to deliver adequate gas for the boiler to fire at the nameplate input at a line pressure between the minimum and maximum values shown on the rating plate. For more information on gas line sizing, consult the utility or the *National Fuel Gas Code*.

Figure 7.1 shows typical gas piping connections to the CWD boiler. A sediment trap must be installed upstream of all gas controls. Install a manual shutoff valve outside the jacket and ground joint union as shown.

The boiler and its gas connection must be leak tested before placing the boiler in operation. When doing this, the boiler and its individual shut-off must be disconnected from the rest of the system during any pressure testing of that system at pressures in excess of  $\frac{1}{2}$  psi. When pressure testing the gas system at pressures of  $\frac{1}{2}$  psi or less, isolate the boiler from the gas supply system by closing its individual manual shut-off valve.



**FIGURE 7.1: GAS CONNECTION TO BOILER**

## VIII System Piping



### WARNING

- INSTALL BOILER SO THAT THE GAS IGNITION SYSTEM COMPONENTS ARE PROTECTED FROM WATER (DRIPPING, SPRAYING, RAIN, ETC.) DURING APPLIANCE OPERATION AND SERVICE (CIRCULATOR REPLACEMENT, ETC.).
- OPERATION OF THIS BOILER WITH CONTINUOUS RETURN TEMPERATURES BELOW 120°F CAN CAUSE SEVERE HEAT EXCHANGER CORROSION DAMAGE.
- OPERATION OF THIS BOILER IN A SYSTEM HAVING SIGNIFICANT AMOUNTS OF DISSOLVED OXYGEN CAN CAUSE SEVERE HEAT EXCHANGER CORROSION DAMAGE.
- DO NOT USE TOXIC ADDITIVES, SUCH AS AUTOMOTIVE ANTIFREEZE, IN A HYDRONIC SYSTEM.
- PIPE RELIEF VALVE DISCHARGE TO A SAFE LOCATION. THE RELIEF VALVE MAY DISCHARGE SCALDING HOT WATER.
- DO NOT INSTALL A VALVE IN THE RELIEF VALVE DISCHARGE LINE.
- DO NOT MOVE RELIEF VALVE FROM FACTORY LOCATION.
- DO NOT PLUG RELIEF VALVE DISCHARGE. BLOCKING THE RELIEF VALVE MAY RESULT IN BOILER EXPLOSION.

### A. Standard Piping

Figure 8.1 shows typical boiler system connections on a single zone system. Additional information on hydronic system design may be found in *I=B=R Guide RHH* published by the Air-Conditioning, Heating and Refrigeration Institute (AHRI). The components in this system and their purposes are as follows:

- 1) **Relief valve (Required)** – Install the relief valve in the 3/4” tapping on the left side of the boiler as shown in Figure 2.1. The relief valve shipped with the boiler is set to open at 30 psi. This valve may be replaced with one having a setting of up to the Maximum Allowable Working Pressure (MAWP) shown on the rating plate. If the valve is replaced, the replacement must have a relief capacity in excess of the Minimum Relief Valve Capacity shown on the rating plate.  
Pipe the discharge of the relief valve to a location where water or steam will not create a hazard or cause property damage if the valve opens. The end of the discharge pipe must terminate in an unthreaded pipe. If the relief valve discharge is not piped to a drain, it must terminate at least 6 inches above the floor. Do not run relief valve discharge piping through an area that is prone to freezing. The termination of the relief valve discharge piping must be in an area where it is not likely to become plugged by debris.
- 2) **Circulator (Required)** – Although the circulator is shipped on the boiler return, it can be installed on the boiler supply. If the circulator is moved to the supply it should be positioned just downstream of the expansion tank as shown in Figure 8.1.
- 3) **Expansion Tank (Required)** – If this boiler is replacing an existing boiler with no other changes in the system, the old expansion tank can generally be reused. If the expansion tank must be replaced, consult the expansion tank manufacturer’s literature for proper sizing.
- 4) **Fill Valve (Required)** – Either a manual or automatic fill valve may be used. The ideal location for the fill is at the expansion tank.
- 5) **Automatic Air Vent (Required)** – At least one automatic air vent is required. Manual vents will usually be required in other parts of the system to remove air during initial fill.
- 6) **Low Water Cut-Off (Required in some situations)** – A low water cut-off is required when the boiler is installed above radiation. In addition, some codes, such as ASME CSD-1, require low water cut-offs. Codes may also require that this low water cut-off have a manual reset function. The low water cut-off may be a float type or probe type but must be designed for use in a hot-water system. The low water cut-off should be piped into the boiler supply just above the boiler with no intervening valve between it and the boiler.  
Use a low water cut-off that breaks the 120 VAC supply to the boiler. **Do not attempt to connect a 24-volt low water cut-off into the boiler factory wiring.**



- 7) Manual Reset High Limit (Required by some codes) – This control is required by ASME CSD-1 and some other codes. Install the high limit in the boiler supply piping just beyond the boiler with no intervening valves. Set manual reset high limit as far above the operating limit setting as possible, but not over 240F. Wire the control to break the 120 VAC electrical supply to the boiler.
- 8) Flow control valve (Required under some conditions) – The flow control valve prevents flow through the system unless the circulator is operating. A flow control valve may be necessary on converted gravity systems to prevent gravity circulation. Flow control valves are also used to prevent “ghost flows” in circulator zone systems through zones that are not calling for heat.
- 9) Isolation Valves (Optional) – Isolation valves are useful if the boiler must be drained, as they will eliminate having to drain and refill the entire system.
- 10) Drain Valve – The drain valve is shipped in the boiler parts bag. Install it in the location shown in Figure 2.1.

## **B. Piping for Special Situations**

Certain types of heating systems have additional requirements. Some of the more common variations follow:

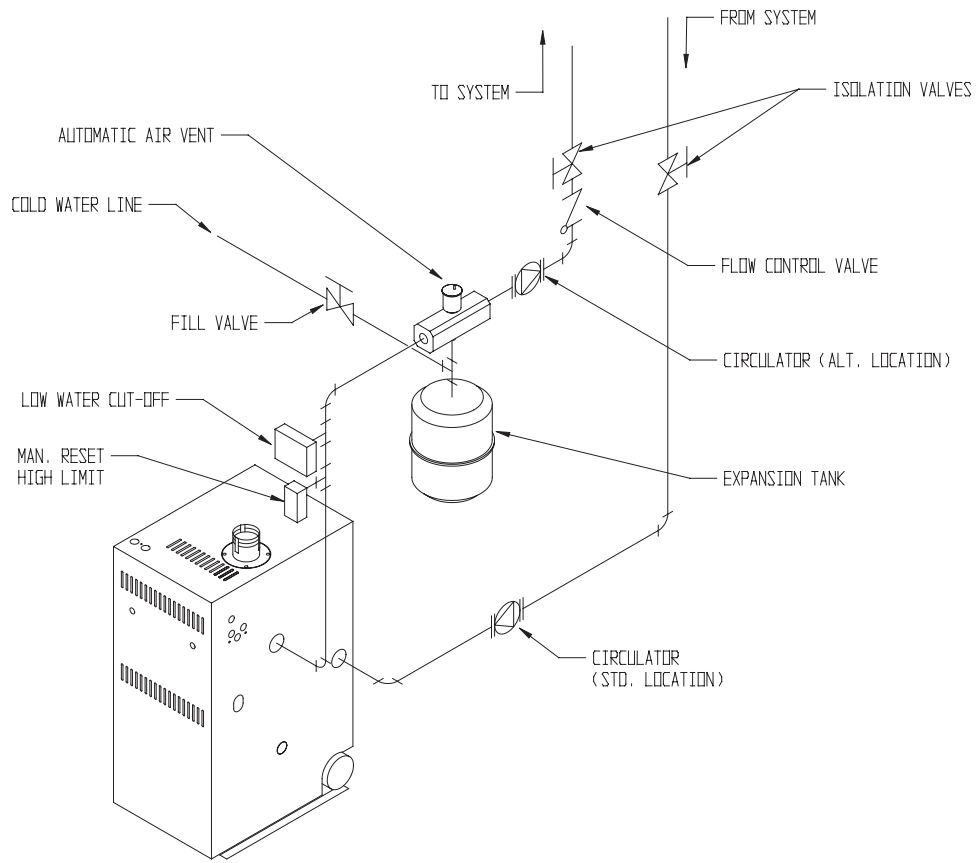
- 1) Indirect Water Heaters – Figure 8.2 shows typical indirect water heater piping. Boiler piping is the same as for any two-zone system. Figure 8.2 shows circulator zoning, which is usually preferred for indirect water heaters. Size the circulator and indirect water heater piping to obtain the boiler water flow through the indirect water heater called for by the indirect water heater manufacturer. The standard CWD control system will operate two circulator zones. See the Wiring section of this manual.
- 2) Gravity and “Large Water Volume” Systems – The piping shown in Figure 8.3 will minimize the amount of time that the boiler operates with return temperatures below 120F on these systems. A bypass is installed as shown to divert some supply water directly into the return water. The bypass pipe should be the same size as the supply. The two throttling valves shown are adjusted so that the return temperature rises above 120F during the first few minutes of operation. A three-way valve can be substituted for the two throttling valves shown. If the circulator is mounted on the supply, the bypass must be on the discharge side of the circulator.
- 3) Low Temperature Systems – Some systems, such as radiant tubing systems, require the system water temperature to be limited to a value below the temperature of the water leaving the CWD. These systems also typically have return temperatures well below the 120F minimum.  
 Figure 8.4 illustrates the use of a heat exchanger to connect a CWD boiler to this type of system. The heat exchanger will permit the transfer of heat from the boiler water to the low temperature system while holding the system supply and boiler return temperatures within their limits. For this system to work properly, the heat exchanger must be properly sized and the correct flow rates are required on either side of the heat exchanger. Consult the heat exchanger manufacturer for sizing information. The water in the boiler is completely isolated from the water in the system. This means that separate fill and expansion tanks are required for the heating system loop.  
 There are several other ways to connect low temperature systems to the non-condensing boilers like the CWD such as four way mixing valve and variable speed injection pumping systems.
- 4) Systems containing oxygen – Many hydronic systems contain enough dissolved oxygen to cause severe corrosion damage to a cast iron boiler such as the CWD. Some examples include:
  - Radiant systems that employ tubing without an oxygen barrier.
  - Systems with routine additions of fresh water.
  - Systems which are open to the atmosphere.

If the boiler is to be used in such a system, it must be separated from the oxygenated water being heated with a heat exchanger as shown in Figure 8.4.

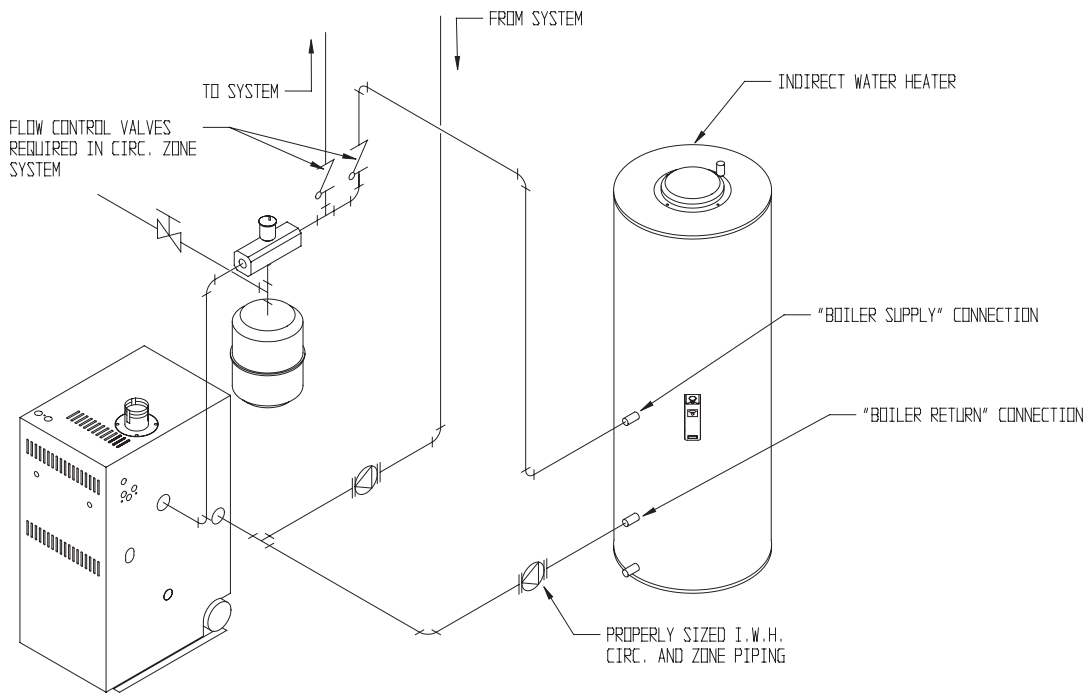
Consult the heat exchanger manufacturer for proper heat exchanger sizing as well as flow and temperature requirements. All components on the oxygenated side of the heat exchanger, such as the pump and expansion tank, must be designed for use in oxygenated water.

- 5) Piping with a Chiller – If the boiler is used in conjunction with a chiller, pipe the boiler and chiller in parallel as shown in Figure 8.5. Use isolation valves to prevent chilled water from entering the boiler.
- 6) Air Handlers – Where the boiler is connected to air handlers through which refrigerated air passes, use flow control valves in the boiler piping or other automatic means to prevent gravity circulation during the cooling cycle.

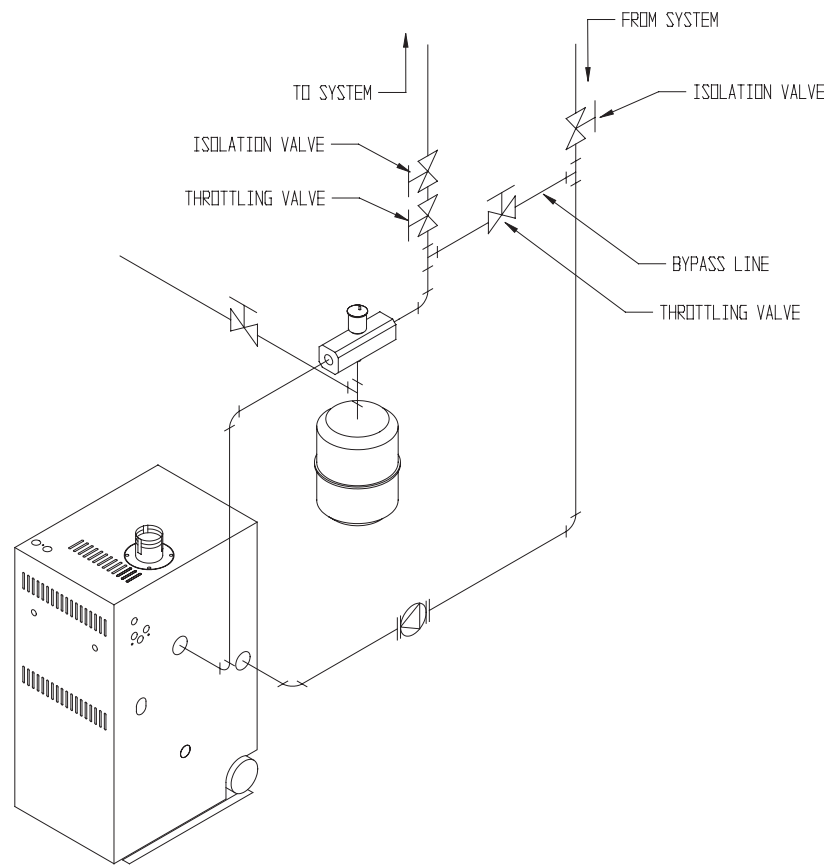




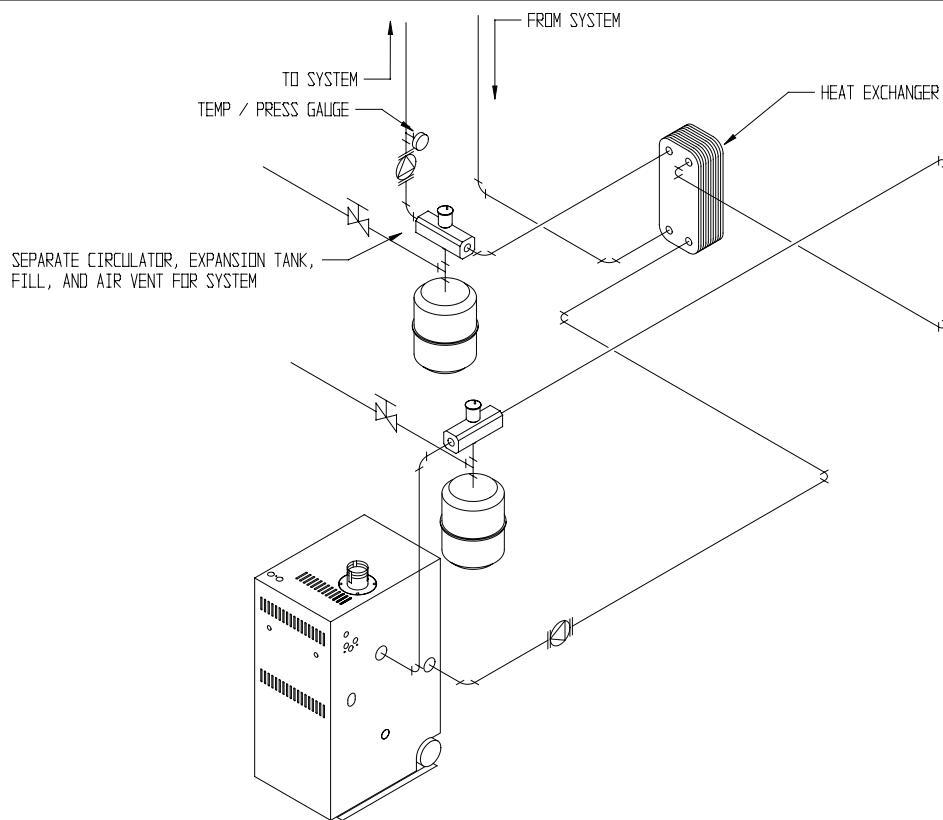
**FIGURE 8.1: BASIC PIPING**



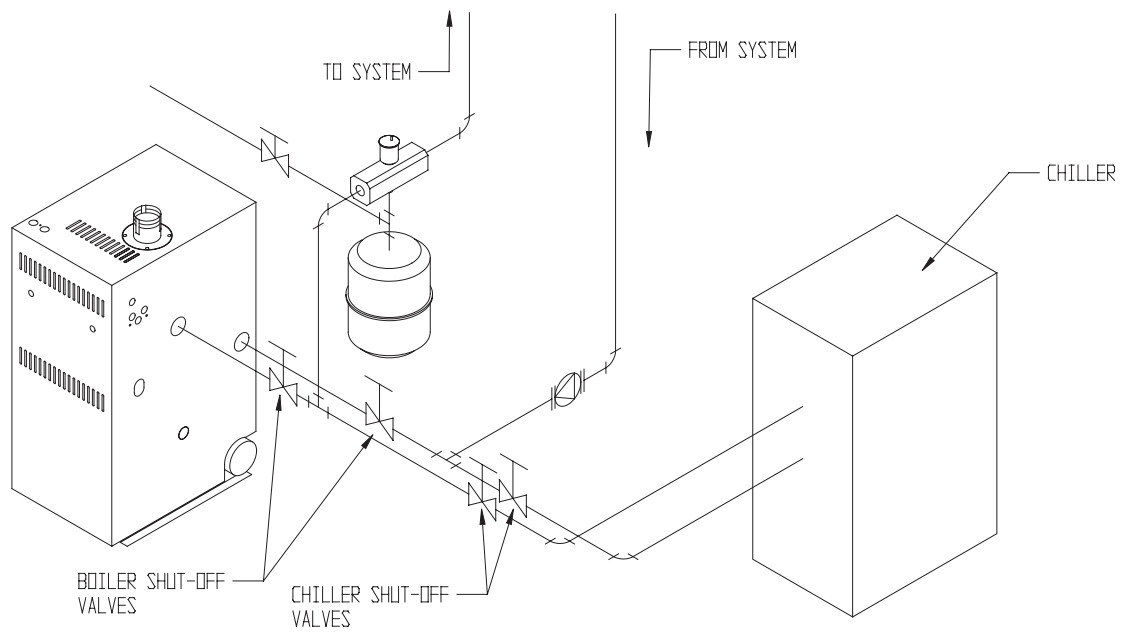
**FIGURE 8.2: INDIRECT WATER HEATER BOILER-SIDE PIPING**



**FIGURE 8.3: BYPASS PIPING**



**FIGURE 8.4: ISOLATION OF BOILER FROM SYSTEM WITH HEAT EXCHANGER**



**FIGURE 8.5: CHILLER PIPING**

## Section IX Wiring



### WARNING

- All wiring and grounding must be done in accordance with the authority having jurisdiction or, in the absence of such requirements, with the *national electrical code* (ansi/nfpa 70).
- Disconnect electrical power to the boiler and heating system before servicing. Positively assure that no voltage is present. Lock electrical boxes to prevent someone from inadvertently restoring power before the heating system is safe to operate.
- Never defeat or jump out safety devices.
- Protect each boiler circuit with a properly sized over-current protection device.
- Make electrical connections carefully according to the boiler's wiring diagram and instructions.
- Wire additional field supplied safety limits, such as low water cutoffs and temperature limit devices, in series with the 120v circuit used to power the boiler. Do not alter the boiler's factory wiring when adding an additional limit device.

1) Line Voltage (120 VAC) Field Connections – See Figure 9.0 for line voltage connections. Provide a dedicated circuit for the boiler of 15A or greater. A service switch is recommended and is required by many local codes. Locate this switch in accordance with local codes or, in the absence of any, in a location where it can be safely accessed in an emergency involving the boiler. All 120VAC connections to the boiler itself are made inside the junction box on the right side of the boiler. 120VAC connections are:

- Ground
- 120VAC Hot (Black)
- 120VAC Neutral (White)
- Heating Circulator Hot (Red)
- Heating Circulator Neutral (White)
- DHW Circulator Hot (Blue)
- DHW Circulator Neutral (White)

The use of the Circulator outputs are as follows:

- a) Heating Circulator - Pumps water upon a call for heat (CH) from a heating thermostat connected to the leads shown in Figure 9.1 or from an EnviraCom thermostat.
- b) DHW Circulator - Pumps boiler water to an indirect water heater upon a call for domestic hot water (DHW) from the DHW thermostat terminals shown in Figure 9.1. This output can also be used for a second space heating zone. See Section Xb of this manual for additional information.

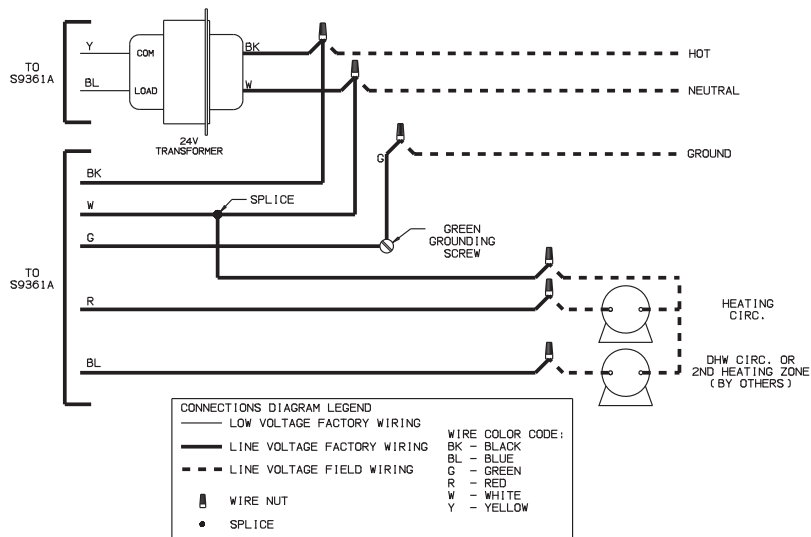
Maximum circulator current draw is 5.0 FLA.

2) Low Voltage Connections – Low voltage field connections are located as shown in Figure 9.1 and are as follows:

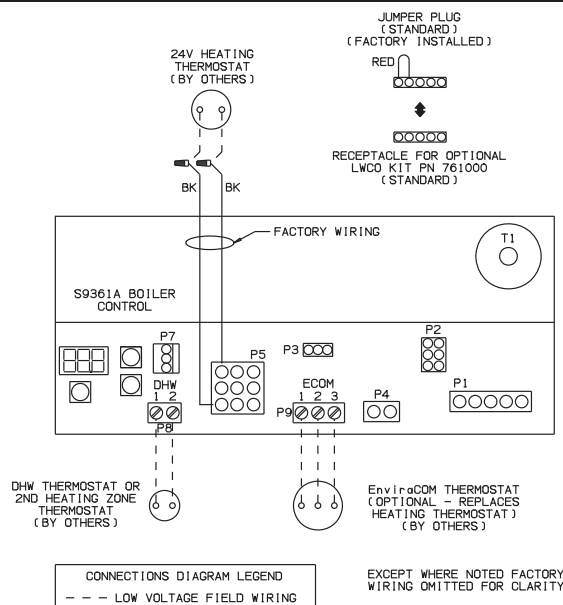
- a) Heating Thermostat - Connect to a 24 volt thermostat or other “dry contacts” (such as a zone panel end switch) that close upon a call for heat. Follow thermostat manufacturer's instructions. To insure proper thermostat operation, avoid installation in areas of poor air circulation, hot spots (near any heat source or in direct sunlight), cold spots (outside walls, walls adjacent to unheated areas, locations subject to drafts). Provide Class II circuit between thermostat (or zone controls) and boiler.
- b) DHW - If used, connect to a 24VAC domestic hot water thermostat or 2nd space heating thermostat.
- c) Option Plug - Used to connect Crown #761000 optional LWCO kit. If this kit is not installed, the factory supplied jumper plug shown in Figure 9.1 must be installed for boiler to operate.
- d) EnviraCOM - Used to connect an EnviraCom thermostat or other EnviraCom device approved by Crown to this boiler.

## CAUTION

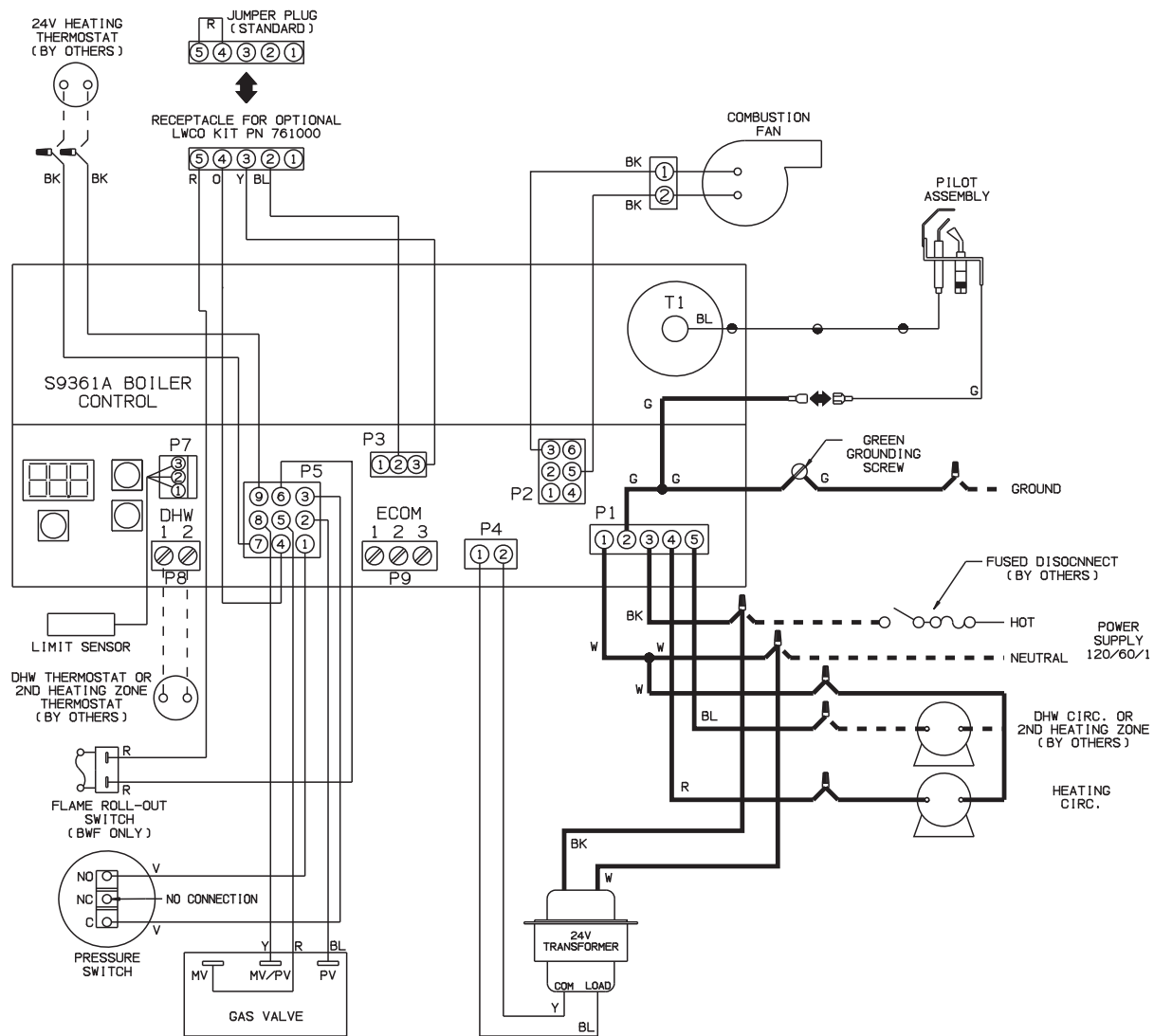
- When making low voltage connections, make sure that no external power source is present in the thermostat circuits. If such a power source is present, it could destroy the boiler's control. One example of an external power source that could be inadvertently connected to the low voltage connections is a transformer in old thermostat wiring.
- Do not attempt to use EnviraCom connections for any purpose not explicitly permitted by Crown Boiler Company. Attempting to do so may result in unreliable operation and/or damage to controls.
- Do not use the transformer provided on the boiler to power external devices such as zone valves. Doing so may cause damage to the transformer.



**FIGURE 9.0: LINE VOLTAGE CONNECTIONS**



**FIGURE 9.1: LOW VOLTAGE CONNECTIONS**



**SYMBOLS**

- LOW VOLTAGE FACTORY WIRING SIZE 18 AWG TYPE AWM STRANDED WIRE, 105°C
- LINE VOLTAGE FACTORY WIRING SIZE 14 AWG TYPE AWM STRANDED WIRE, 105°C
- - - LINE VOLTAGE FIELD WIRING
- - - LOW VOLTAGE FIELD WIRING
- IGNITOR - 250°C
- ◆ CONNECTOR
- ⊞ WIRE NUT
- SPLICE

**NOTES:**

- IF ANY OF THE ORIGINAL WIRE SUPPLIED WITH THE APPLIANCE MUST BE REPLACED, IT MUST BE REPLACED WITH THE SAME TYPE SHOWN OR ITS EQUIVALENT.

**WIRE COLOR CODE:**

- BK - BLACK
- BL - BLUE
- G - GREEN
- O - ORANGE
- R - RED
- V - VIOLET
- W - WHITE
- Y - YELLOW
- R/Y - RED W/ YELLOW TRACE

**FIGURE 9.2: INTERNAL CONNECTIONS DIAGRAM**

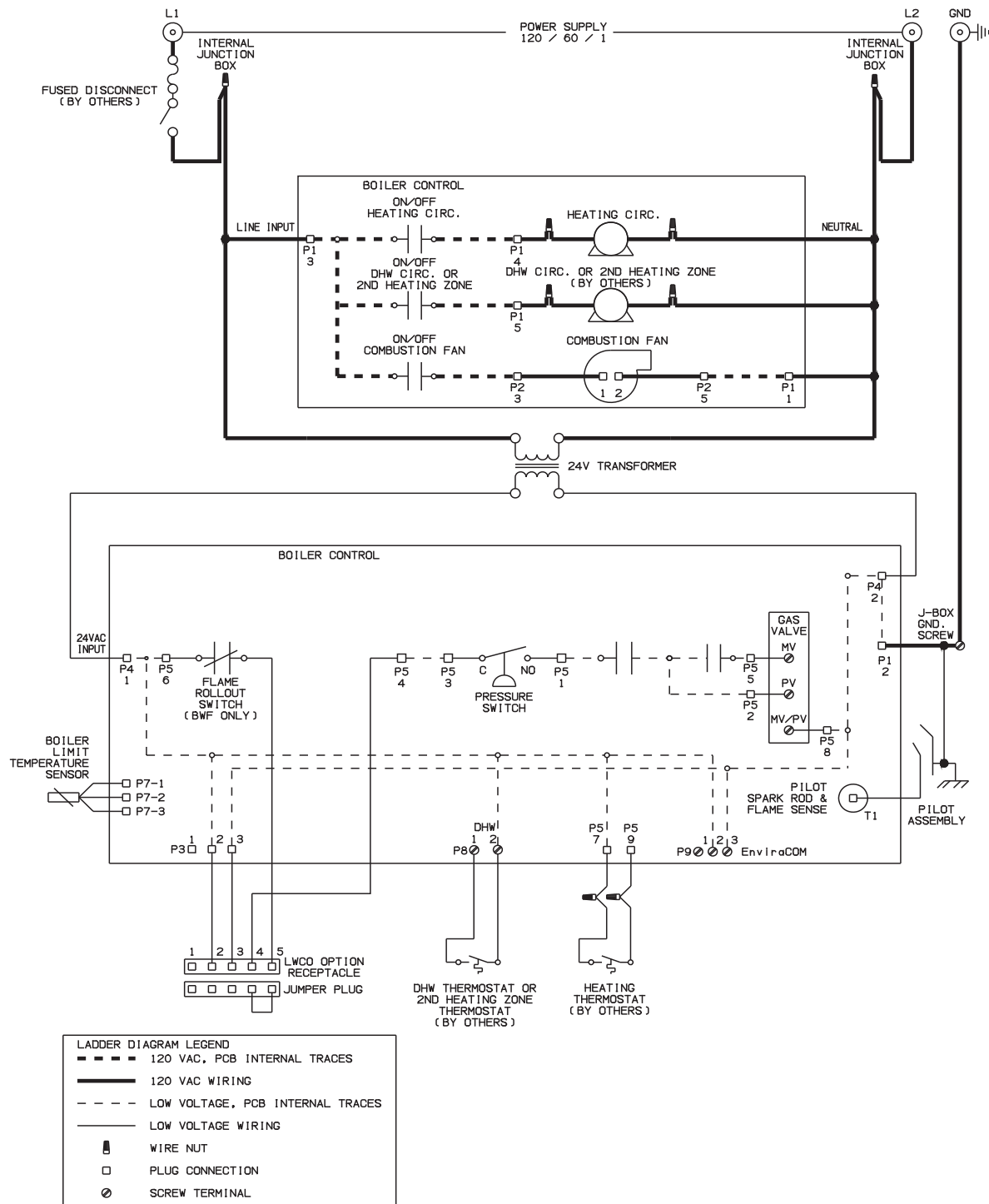


FIGURE 9.3: LADDER DIAGRAM

## X Start-up and Checkout



### WARNING

DO NOT LEAVE THE BOILER IN SERVICE IF IT FAILS ANY OF THE FOLLOWING START-UP CHECKS. DOING SO MAY RESULT IN FIRE, EXPLOSION, OR CARBON MONOXIDE (CO) POISONING.



### WARNING

- GAS LEAKS MAY RESULT IN FIRE OR EXPLOSION.
- NEVER USE A FLAME TO CHECK FOR GAS LEAKS.
- MAKE SURE THAT THE AREA AROUND THE BOILER IS CLEAR AND FREE FROM COMBUSTIBLE MATERIALS, GASOLINE AND OTHER FLAMMABLE VAPORS AND LIQUIDS.
- WATER LEAKS MAY CAUSE EXTENSIVE PROPERTY DAMAGE.

### NOTE

SAFE LIGHTING AND OTHER PERFORMANCE CRITERIA WERE MET WITH THE GAS MANIFOLD AND CONTROL ASSEMBLY PROVIDED ON THE BOILER WHEN THE BOILER UNDERWENT THE TESTS SPECIFIED IN Z21.13.

Use the following procedure for initial start-up of the boiler:

- 1) Make sure that the boiler and system are filled with water.
- 2) Check all new gas piping for leaks and purge piping sections that are filled with air. See the *National Fuel Gas Code* for additional information on testing and purging gas lines.
- 3) Verify that vent system is complete and free of obstructions before attempting to fire boiler. Make sure that the silicone cure time called for in the vent assembly instructions has passed before firing boiler.
- 4) Inspect all wiring for loose or uninsulated connections.
- 5) Adjust thermostat to the highest setting.
- 6) Start the boiler using the lighting instructions on the opposite page.
- 7) Upon initial start-up, the gas train will be filled with air. Even if the gas line has been completely purged of air, it may take several tries for ignition before a flame is established. Once a flame has been established for the first time, subsequent calls for burner operation should result in a flame on the first try.
- 8) Observe pilot burner flame. Pilot burner produces three flames. The center one should be a steady medium blue flame covering around 3/8" to 1/2" of spark electrode / flame rod (Figure 10.1).
- 9) Inspect the main burner flames visible through the observation port in burner access panel. The flame should be stable and mostly blue. No yellow tipping should be present; however, intermittent flecks of yellow and orange in the flame are normal (Figure 10.2).
- 10) Check entire gas train for leaks using soap and water or other approved leak detection method while boiler is firing. Fix any leaks found immediately.
- 11) Run gas valve safety shutdown test. With main burners firing, disconnect ignition cable from ignition module. Both pilot burner and main burners should stop firing.



## FOR YOUR SAFETY READ BEFORE OPERATING

**WARNING:** If you do not follow these instructions exactly, a fire or explosion may result causing property damage, personal injury or loss of life.

- A. This appliance is equipped with an ignition device which automatically lights the pilot. Do not try to light the pilot by hand.
- B. BEFORE LIGHTING smell all around the appliance area for gas. Be sure to smell next to the floor because some gas is heavier than air and will settle on the floor.

### WHAT TO DO IF YOU SMELL GAS

- Do not try to light any appliance.
- Do not touch any electric switch; do not use any phone in your building.
- Immediately call your gas supplier from a neighbor's phone. Follow the gas supplier's instructions.

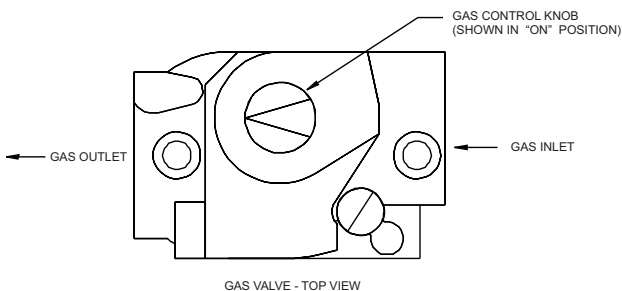
- If you cannot reach your gas supplier, call the fire department.

- C. Use only your hand to push in or turn the gas control knob. Never use tools. If the knob will not push in or turn by hand, don't try to repair it, call a qualified service technician. Force or attempted repair may result in a fire or explosion.

- D. Do not use this appliance if any part has been under water. Immediately call a qualified service technician to inspect the appliance and to replace any part of the control system and any gas control which has been under water.

## OPERATING INSTRUCTIONS

1. STOP! Read the safety information above on this label.
2. Set the thermostat to lowest setting.
3. Turn off all electric power to the appliance.
4. This appliance is equipped with an ignition device which automatically lights the pilot. Do not try to light the pilot by hand.



5. Remove front access panel.
6. Rotate the gas control knob clockwise ↻ to OFF.
7. Wait five (5) minutes to clear out any gas. Then smell for gas, including near the floor. If you then smell gas, STOP! Follow "B" in the safety information above on this label. If you don't smell gas go to the next step.
8. Rotate the gas control knob counter clockwise ↻ to "ON".
9. Replace front access panel.
10. Turn on all electric power to the appliance.
11. Set thermostat to desired setting.
12. If the appliance will not operate, follow the instructions "To Turn Off Gas To Appliance" and call your service technician or gas supplier.

## TO TURN OFF GAS TO APPLIANCE

1. Set the thermostat to lowest setting.
2. Turn off all electric power to the appliance if service is to be performed.
3. Push in gas control knob slightly and turn clockwise ↻ to "OFF". Do not Force.



## WARNING

Failure to follow the following procedure exactly could result in over-firing of the boiler and a carbon monoxide hazard.

12) Check the manifold pressure and adjust if necessary. To do this, use the following procedure:

- a) Connect a manometer to the line pressure tap on the gas valve (see Figure 10.3).
- b) Check the line pressure with all gas appliances on and off. The line pressure at the boiler must be within the following limits regardless of what combination of appliances is firing:

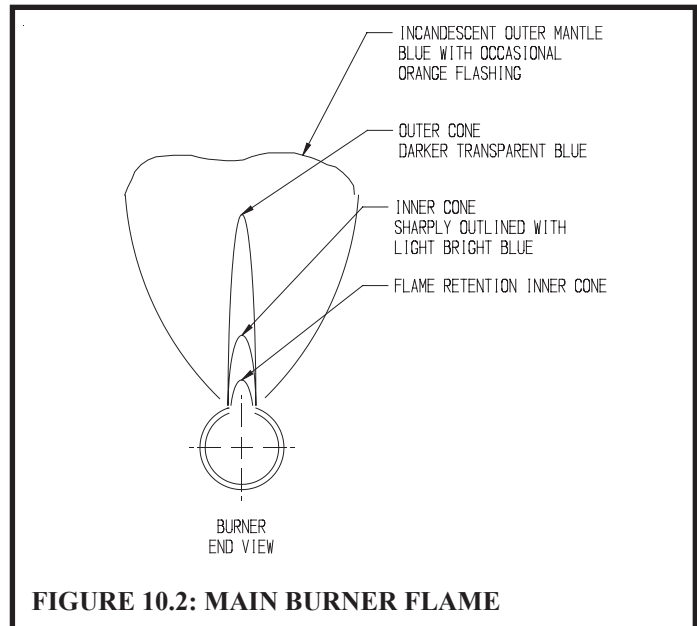
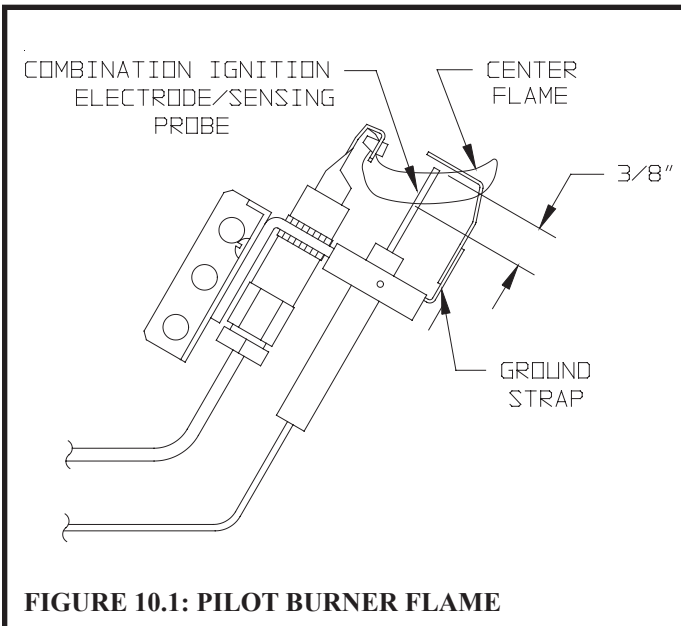
<u>Line Press (inches w.c.)</u>	<u>Natural Gas</u>	<u>LP Gas</u>
Minimum	5.0	11.0
Maximum	14.0	13.0

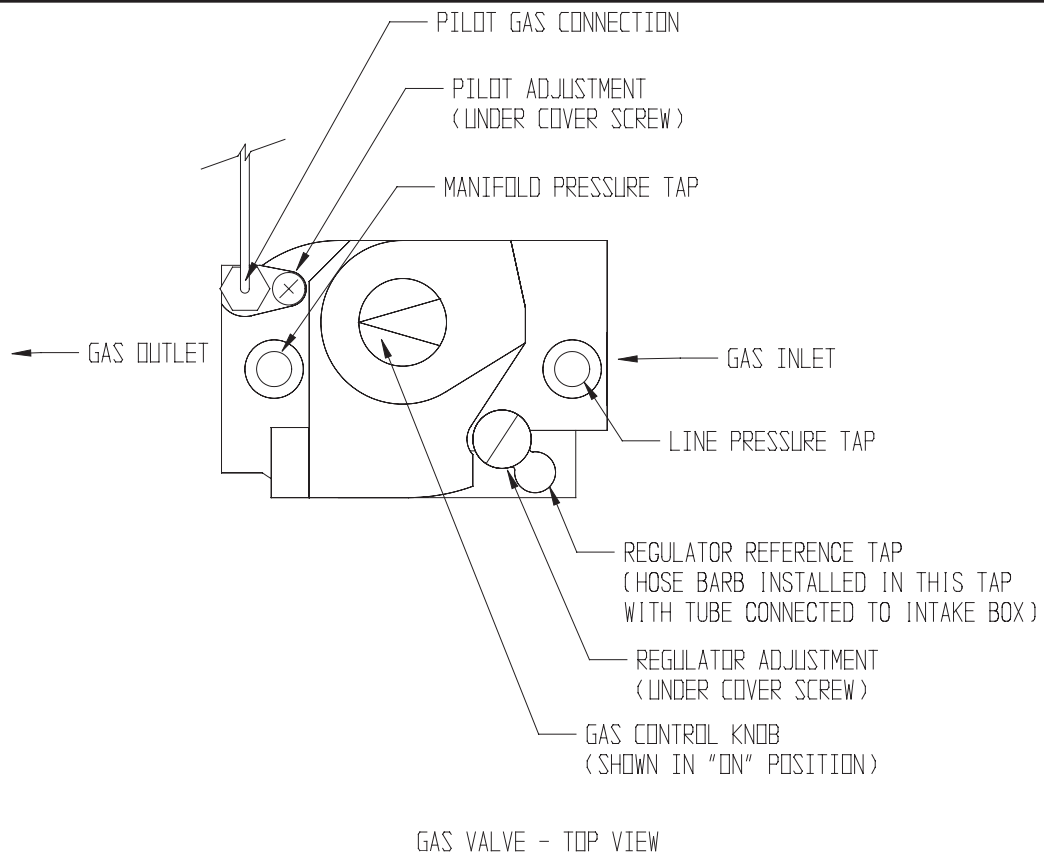
If the line pressure falls outside of these limits, find and correct the cause of the problem before proceeding further.

- c) Disconnect the silicone regulator tube from the hose barb on the gas valve (Figure 10.4).
- d) Connect a manometer to the manifold (outlet) pressure tap on the gas valve (Figure 10.3).
- e) Read the manifold pressure. It should be set at:

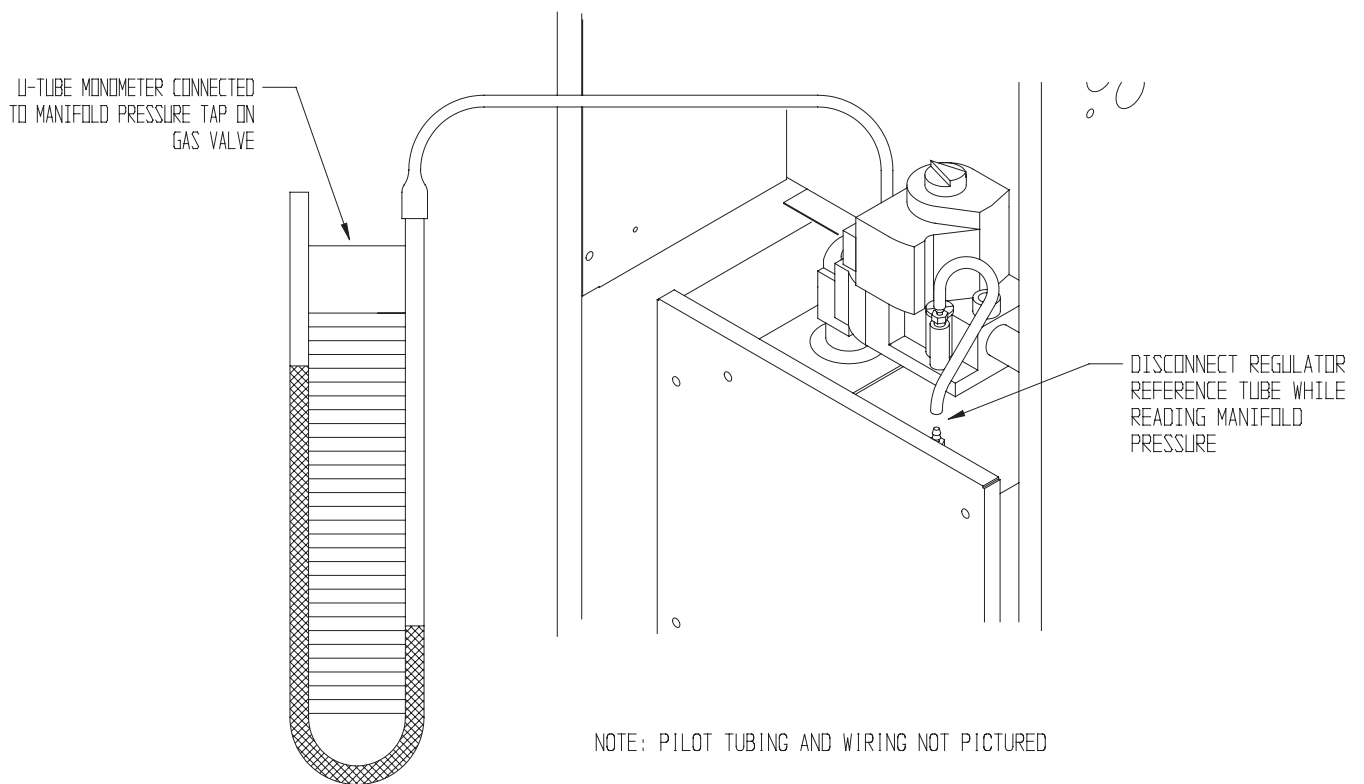
<u>Manifold Press. (inches w.c.)</u>	<u>Natural Gas</u>	<u>LP Gas</u>
	3.5	10.0

- e) If a manifold pressure adjustment is needed, make the adjustment by turning the regulator screw (see Figure 10.3) clockwise to raise the pressure and counter-clockwise to reduce the pressure. If a manifold pressure adjustment is made, recheck the line pressure to be certain that it is still within acceptable limits. Replace the cover screw on the regulator.
  - f) Reconnect the silicone regulator tube disconnected in Step (c)
- 13) Test thermostat operation while the boiler is running. Turn the thermostat to the lowest setting. Circulator should stop running. Raise the thermostat back to the highest setting. Circulator should restart. The pilot burner and main burners should relight.
- 14) Verify high limit operation. Allow the boiler water temperature to increase to high limit setting. Circulator should continue running and pilot burner and main burners should stop firing. When water temperature drops below the limit setting, the pilot burner and main burners should relight.
- 15) After the boiler has operated for approximately 30 minutes, check the boiler and heating system piping for leaks. Repair any leaks found at once.
- 16) Inspect the vent system for flue gas leaks. Repair any leaks found before leaving the boiler in operation.





**FIGURE 10.3: GAS VALVE**



**FIGURE 10.4: MEASURING MANIFOLD PRESSURE**

# XI Operation

## A. General Information

This boiler uses a proprietary version of the Honeywell S9361A “integrated boiler control” to manage all boiler functions including flame supervision, temperature control, and circulator operation. This control can operate one or two circulator zones without the use of additional relays.

In accordance with the 2007 Energy and Independence Security Act, this control first attempts to use residual heat in the boiler to satisfy a space heating demand before firing the burner. In this manual, this function is referred to as a “thermal purge”. For additional information see Part C of this section.

## B. Reading Status and Using Menu

The boiler’s status, as well as all parameters, are viewed and adjusted using the 3 digit LED and three buttons shown in Figure 11.1. The S9361A has four basic modes of operation (also see Figure 11.2):

- 1) Status Mode - This is the default mode of operation for the control. In it, the display alternates between  $5\text{E}9$  and a number indicating the current status of the boiler. A list and description of these status numbers is shown in Table 11.3 and is also shown on the face of the control itself.
- 2) Operating Mode - Provides additional information about the current status of the boiler. Operating mode is entered by pressing the **I** button shown in Figure 11.1. When this button is first pressed in Status mode, the display will alternately display  $h\text{E}$  and the current boiler water temperature as shown in Figure 11.4. Pressing the **I** button again will display the next line item shown in Table 11.3. In the same manner it is possible to advance through all of the “parameters” shown in Table 11.3. To return to Status mode, press **I** repeatedly until  $5\text{E}9$  once again appears on the display. Alternatively, the control will return to Status mode if no key is touched for 30 minutes.
- 3) Error Mode - In Error mode, the control alternately displays  $E\text{r}$  and an error code. A list of these error codes is found on the front of the control, as well as in Section XII of this manual (along with suggested corrective actions).
- 4) Adjustment Mode - Used to change parameters, such as high limit setting. See Part C for using Adjustment Mode.

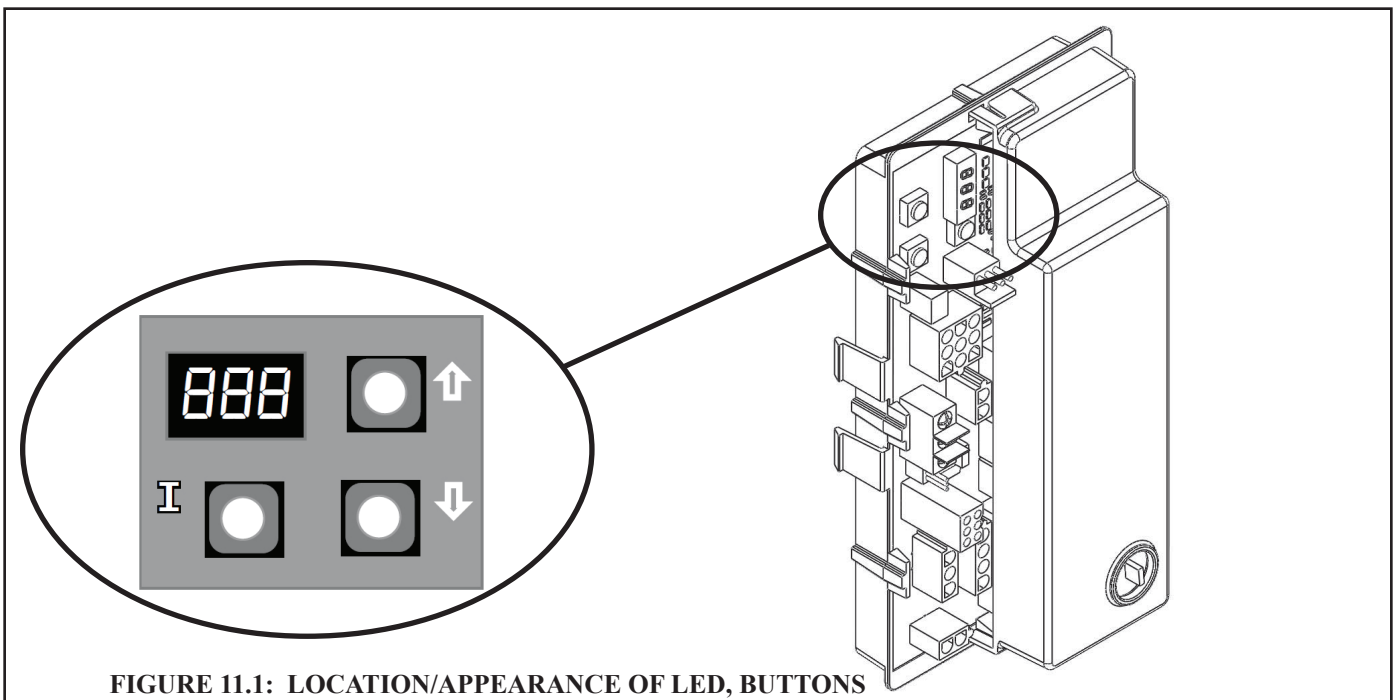
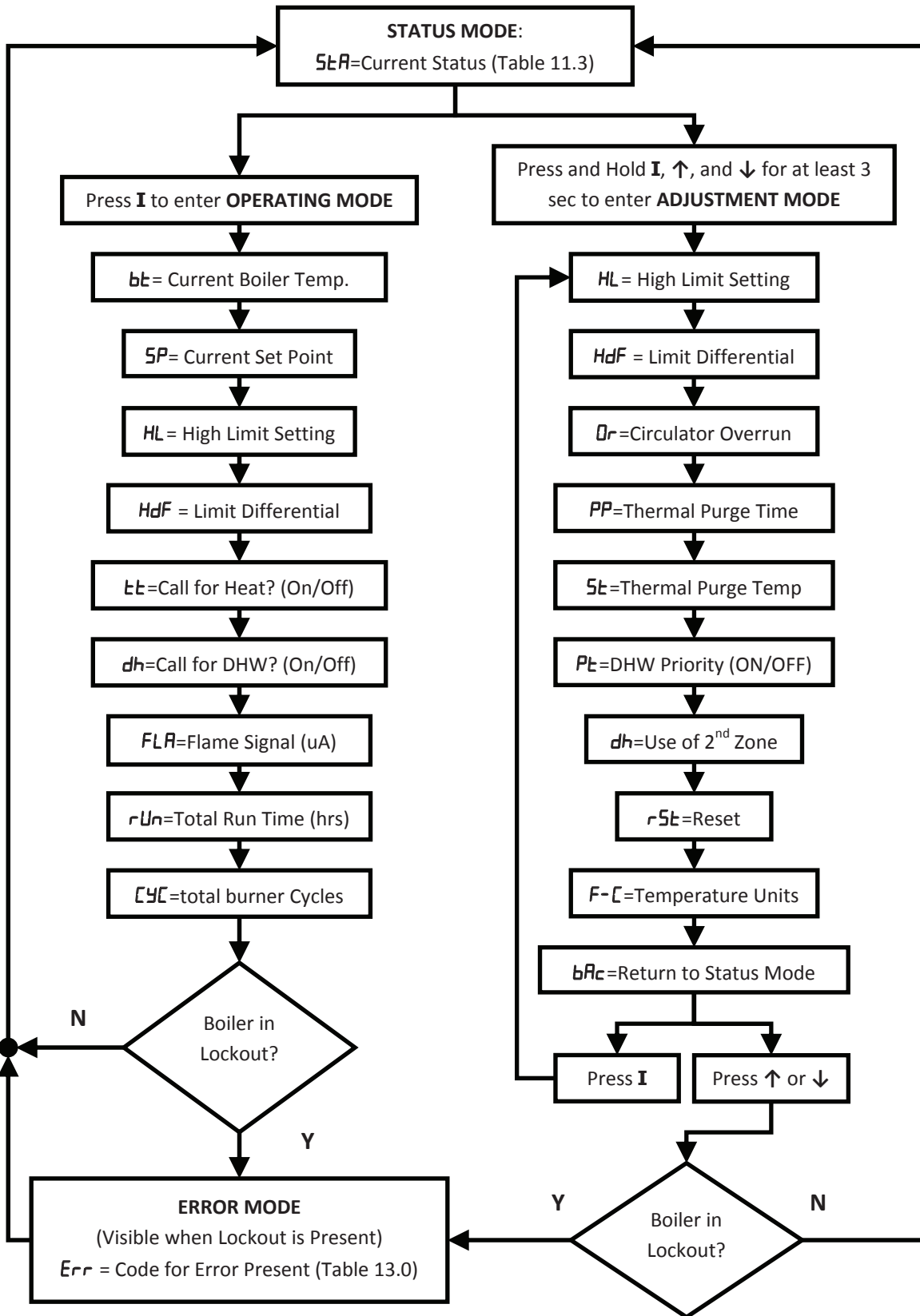


FIGURE 11.1: LOCATION/APPEARANCE OF LED, BUTTONS

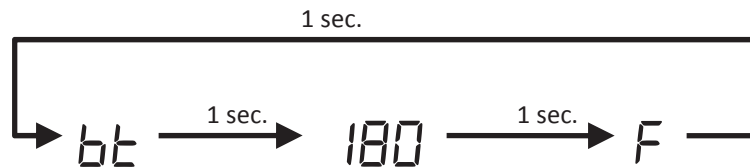
FIGURE 11.2: BOILER CONTROL MENU



- Except as shown above, press **I** to navigate through menu.
- Use **↑, ↓** to change parameters in Adjustment Mode

**TABLE 11.3: STATUS CODES**

Status #	Description	Meaning
1	Standby	No call for heat or DHW OR Call for heat present , but boiler is in thermal purge (See <i>PP</i> on page 54) OR Call for heat/DHW present but boiler temperature is above high limit ( <i>HL</i> ) setting.
2	Waiting for Pressure Switch to open	Control is confirming that air pressure switch contacts are open before starting fan.
3	Waiting for Pressure Switch to close	Fan is on and control is waiting for air pressure switch contacts to close.
4	Prepurge	Pressure switch is closed and control is waiting 30s before starting trial for ignition.
5	Spark	Control is attempting to light pilot
7	Flame proving	Control is verifying that the pilot flame is on and stable.
8	Running	Main burner is on
10	Retry/Recycle Delay	Control was unable to establish pilot and is waiting 60 seconds before trying again OR Proof of pilot was lost after pilot was established and control is waiting 60 seconds before attempting to relight.
11	Pressure Switch failed to open.	Control waited in Status #2 for 60 seconds and air pressure switch remained closed. Boiler will remain in this state until the air pressure switch opens.
12	Pressure Switch failed to close.	Control waited in Status #3 for 60 seconds and air pressure switch failed to close. Boiler will remain in this state until the air pressure switch closes.
13	Soft Lockout	A fault is preventing the boiler from firing. Boiler will be allowed to fire after problem clears itself AND a forced delay period has passed.
14	Hard Lockout	A fault has occurred which requires manual intervention before the boiler will again operate. This intervention can be in the form of interruption of the power supply to the boiler or resetting the control in Adjustment mode.
15	Waiting for limit to close	LWCO open (if LWCO kit PN 761000 installed), limit jumper plug missing, or flame rollout switch open (BWF series only)
16	Flame Present out of Sequence	A flame was detected when none should have been present.
17	Self test	Boiler was just energized and control is running a self check.



**FIGURE 11.4: TYPICAL OPERATING MODE DISPLAY (BOILER TEMP SHOWN)**

**NOTE**

In operating mode, holding either the  $\uparrow$  or  $\downarrow$  button while viewing a given parameter will keep the display on the actual reading. For example, pressing  $\uparrow$  while reading boiler temperature as shown in Figure 11.4 will keep the display on 180 for as long as the button is held. This makes it easier to view readings “live” if they are changing rapidly.

**TABLE 11.5: OPERATING MODE PARAMETERS**

Parameter #	Description	Meaning
<i>bT</i>	Boiler Temperature	Current boiler water temperature measured by the control's sensor.
<i>SP</i>	Boiler water set point	Current target temperature (always the same as the high limit setting unless Crown outdoor reset card option is installed).
<i>HL</i>	High Limit Set point	Boiler will stop firing if boiler water temperature exceeds this value (Circulator/s will continue to operate)
<i>HdF</i>	High Limit Differential	If high limit setting is reached, boiler water temperature will need to drop by this amount before boiler will again fire during the same call for heat.
<i>tT</i>	Heat Request Status	Shown as either ON or OFF. Indicates whether there is a call for heat.
<i>dh</i>	DHW Request Status	Shown as either ON or OFF. Indicates whether there is a call for domestic hot water (DHW). Note that if the dh zone on the S9361A is used as a second heating zone (see Table 11.6), this parameter will be shown as OFF and it will be shown as ON when this zone calls for heat.
<i>FLA</i>	Flame Current	Flame rectification signal (uA)
<i>rUn</i>	Run Time Hours	Total amount of time gas valve has been open (burner firing) since control was new (hours, starting from 1).
<i>CYC</i>	Boiler Cycles	Total number of burner cycles on the control
<i>Err</i>	Error Number	Present only if the control has detected a problem. See Table 13.0 for a list of error codes and suggested corrections.

**TABLE 11.6: ADJUSTMENT MODE PARAMETERS**

Status #	Description	Factory Setting	Permissible Range
<i>HL</i>	High Limit Set point	180F	140-220F
<i>dF</i>	High Limit Differential	15F	10-30F
<i>Or</i>	Circulator overrun	0 min	0-10 minutes
<i>PP</i>	Thermal Purge time	2 min	2-20 minutes
<i>St</i>	Thermal Purge Start Temp	140F	140-180F
<i>Pt</i>	DHW Priority	ON	ON or OFF
<i>dh</i>	Use of Second Zone	dh	dh (dhw) or tt2 (2nd heating zone).
<i>rSt</i>	Reset	N/A	OFF or Momentary ON
<i>F-C</i>	Temperature Units	F	F or C
<i>bAc</i>	Exit Adj. mode	N/A	N/A

## C. Using Adjustment Mode



### WARNING

Improper adjustments to control parameters could result in unreliable boiler operation, property damage, personal injury, or loss of life. Adjustments should only be made by a qualified heating technician.

A list of parameters which can be changed on this control are shown in Table 11.6. To enter Adjustment mode and change parameters:

- 1) Press and hold **I**, **↑**, **↓** together for at least 3 seconds.
- 2) Use **I** to advance to the parameter which is to be changed.
- 3) Use the **↑** or **↓** buttons to change the setting or select from possible choices. See below for additional information on the use of these parameters.
- 4) If other parameters are to be changed, use the **I** button to advance to the next parameter needing adjustment and change it in the same way.
- 5) After all parameters have been changed, use the **I** button to advance until *bflc* is shown on the display.
- 6) Press either the **↑** or **↓** key to return to Status mode. Alternatively, the control will return to Status mode if no key is touched for 5 minutes.

HL (High limit Set point) - Burners shut down if the boiler water temperature exceeds this setting. The circulator will continue to run. The high limit setting also serves as the water temperature set point (*SP*) during calls for both heat and DHW.

dF (High limit differential) - If the boiler shuts off on high limit, the water temperature must fall by an amount equal to the differential during the same call for heat before the burners will again start. For example, with HL=180 and dF=15, the burners will shut off if the water temperature exceeds 180F and stay off until the temperature falls to 165F (180 - 15). Note that if all calls for heat end while the burners are off on high limit, the burner will not restart during the next call for heat until the thermal purge requirements described below are met.

Or (Circulator Overrun) - Determines how long the Heating Circulator will operate after the call for heat ends. In some cases, this can help reduce energy consumption by sending heat stored in the boiler out into the system. At the same time, caution should be exercised before setting this value to something other than zero. Before doing so, verify that the system will permit flow (e.g. flow is not completely cut-off by closed zone valves) and that the overrun will not cause overheating problems.

Circulator overrun is only possible on the heating zone. The DHW Circulator will not over-run, even if the DHW zone is used as a second heating zone.

PP (Thermal Purge Time) - Upon a call for heat, the boiler will prevent burner operation until either:

- The water temperature drops below the Thermal Purge start temperature (*St*) OR:
- The thermal purge time has passed

For some examples of this operation, see Table 11.7. If the “DHW” zone is used for space heating (*dh=tt2*), this thermal purge function will also keep the burner off at the beginning of a call from the thermostat connected to the “DHW” terminals in the manner described above. If the “DHW” zone is being used for DHW (*dh=dh*), the burners will immediately come on upon a call for DHW as long as the water temperature is below the high limit setting.

Thermal purge is only invoked when a call for heat first appears and the boiler is not already firing. For this reason, if the boiler is already firing in response to an call for heat, and a call for heat appears at the second zone, the boiler will continue to fire.

St (Thermal Purge Start Temperature) - See description for Thermal Purge Time above.



**TABLE 11.7: EXAMPLES OF THERMAL PURGE OPERATION**

Example #	Call for Heat From	Use of DHW Zone	Thermal Purge Settings		Boiler Temp at Begin Call	Boiler Behavior
			Time (P <sub>t</sub> )	Start Temp (S <sub>t</sub> )		
1	T-T	N/A	2 min.	140F	130	<ul style="list-style-type: none"> <li>• Heating Circulator starts immediately</li> <li>• Burner fires immediately</li> </ul>
2	T-T	N/A	2 min.	140F	150	<ul style="list-style-type: none"> <li>• Heating Circulator starts immediately</li> <li>• Burner fires when either: 2 minutes have passed OR Temperature falls below 140</li> </ul>
3	DHW	DHW (dh=dh)	2 min.	140F	150	<ul style="list-style-type: none"> <li>• DHW Circulator starts immediately</li> <li>• Burner fires immediately</li> </ul>
4	Heat T'stat on DHW terminals	Heat (dh=tt2)	2 min.	140F	150	<ul style="list-style-type: none"> <li>• "DHW" Circulator starts immediately</li> <li>• Burner fires when either: 2 minutes have passed OR Temperature falls below 140</li> </ul>
5	T-T	N/A	2 min.	145F	150	<ul style="list-style-type: none"> <li>• Heating Circulator starts immediately</li> <li>• Burner fires when either: 2 minutes have passed OR Temperature falls below 145</li> </ul>
6	T-T	N/A	3 min.	140	150	<ul style="list-style-type: none"> <li>• Heating Circulator starts immediately</li> <li>• Burner fires when either: 3 minutes have passed OR Temperature falls below 140</li> </ul>

P<sub>t</sub> (DHW Priority) - If this feature is turned on, and simultaneous calls for heat and DHW are present, the heating circulator will be forced off for as long as it takes the boiler to satisfy the call for DHW. This feature is sometimes useful when the boiler size is marginal for the peak DHW demand, but should be used with caution as it can result in lack of heat if the DHW call is very long, or if there is a problem with the DHW zone which causes the DHW demand to be indefinite. Figure 11.8 describes the behavior of both the Heating and DHW Circulators with P<sub>t</sub> turned both ON and OFF.

dh (Use of DHW zone) - Although the second zone on the boiler is designated "DHW", it can be used as a second heating zone by setting dh = "tt2" instead of dh="dh". When the "DHW" zone is used for heating, the thermal purge function is active when this zone calls for heat. When dh=tt2, the setting of P<sub>t</sub> (DHW priority) is ignored.

r5t (Reset) - Used to reset the boiler from a hard lockout (as an alternative to momentarily interrupting power to the control). Pressing the up key will turn rst momentarily to on. When it goes back off (typically within one or two seconds), the control is reset.

**F-C (Temperature Units)** - Determines whether temperature units on the S9361A are displayed in F or C. Note that this selection only applies to the temperature displayed on the LED shown in Figure 11.1. Temperature units must be selected independently on the displays of any control options plugged into Option Plugs 1 or 2.

**bAc (Return to Status mode)** - Exits adjustment mode. Any changes made to the parameters described above are saved, and become effective, as soon as they are made; bAc only exits adjustment mode.

#### D. Sequence of Operation

**TABLE 11.8: SUMMARY OF CIRCULATOR BEHAVIOR**

Thermostat Inputs		Use of "DHW" Zone	Parameters		Circulator Outputs	
T-T	"DHW"		2nd Zone (dh)	DHW Priority (Pt)	Heating (Red Circ. Lead)	"DHW" (Blue Circ. Lead)
ON	OFF	DHW	dh=dh	On	ON	OFF
OFF	ON	DHW	dh=dh	On	OFF	ON
ON	ON	DHW	dh=dh	On	OFF	ON
ON	ON	DHW	dh=dh	OFF	ON	ON
ON	OFF	DHW	dh=dh	OFF	ON	OFF
OFF	ON	DHW	dh=dh	OFF	OFF	ON
ON	OFF	Heat	dh=ttt	On or OFF	ON	OFF
OFF	ON	Heat	dh=ttt	On or OFF	OFF	ON
ON	ON	Heat	dh=ttt	On or OFF	ON	ON

(Refer to Figures 9.2 or 9.3 for Connection and Ladder diagrams)

- 1) A call for heat from the thermostat connected to the thermostat leads energizes the Heating Circulator (connected to red and white leads in J-box).
- 2) Depending on the boiler water temperature at the time of the call for heat, the control will do one of two things:
  - If the water temperature is below the thermal purge start temperature (5t), the control will continue the ignition sequence.
  - If the boiler water temperature is above the thermal purge start temperature, the boiler will wait until either of the following conditions are met before continuing the ignition sequence:
    - a) The boiler water temperature falls below the thermal purge start temperature (5t) Factory default is 140F.
    - b) The thermal purge time elapses (PP). Factory default is 2 minutes.
- 3) If the flame roll-out switch, and LWCO contacts are made, the control will verify that the air pressure switch (APS) is open before starting the fan.
- 4) The control energizes the fan and waits for the air pressure switch to close.
- 5) Once the air pressure switch closes, the control waits for a 30s "prepurge period" to pass before attempting to light the pilot.
- 6) The control starts an ignition spark at the pilot and applies 24 volts across the pilot valve (terminals PV and MV/PV on the gas valve).
- 7) Once the pilot is established, the pilot flame will act as a diode, converting the AC current at the electrode to a half wave DC current at the pilot's ground strap. This DC current flows through the boiler to the ground connection on the S9361A. For the ignition module to recognize that a pilot flame is present, the DC current flowing into this terminal must be in excess of approximately 1.0 uA.
- 8) If the pilot is not proven within 60 seconds of the beginning of the trial for ignition, the pilot valve will close and wait 5 minutes before the ignition sequence is retried.
- 9) Once the ignition module detects the presence of a pilot flame, voltage is applied across the main valve (terminals MV and MV/PV on the valve), opening the valve and establishing main flame.

- 1) If the water temperature climbs above the high limit setting during the call for heat, the burner and blower will shut down while the Heating Circulator continues to operate. The ignition sequence will restart (from Step 3) when the water temperature falls to the high limit setting (*HL*) minus the high limit differential (*HLF*).
- 2) A call for DHW results in a sequence of operation that is identical to that described above except for omission of the thermal purge function described in (2).

#### **E. Safety Control Operation**

Air Pressure Switch (APS) - The APS proves that the fan is running before allowing the ignition sequence to proceed. Failure of this switch to close is usually the result of a problem with the vent system, such as a blockage, or a problem with the fan. If this switch must be replaced, it must be replaced with an identical switch or one that is shown in Crown documentation as being a suitable replacement for this boiler (see Parts Section of boiler installation manual).

## XII Service and Maintenance



### WARNING

- THE BOILER CONTAINS REFRACTORY CERAMIC FIBER, A POSSIBLE HUMAN CARCINOGEN. USE A NIOSH APPROVED RESPIRATOR WHEN SERVICING HIGH-TEMPERATURE INSULATION AND GASKET MATERIALS. WASH EXPOSED SKIN GENTLY WITH SOAP AND WATER AFTER CONTACT. WASH EXPOSED CLOTHING SEPERATE FROM NORMAL LAUNDRY.
- LABEL ALL WIRES PRIOR TO DISCONNECTION WHEN SERVICING CONTROLS. WIRING ERRORS CAN CAUSE IMPROPER AND DANGEROUS OPERATION. VERIFY PROPER OPERATION AFTER SERVICING.
- FAILURE TO MAINTAIN THE BOILER IN PROPER WORKING CONDITION MAY LEAD TO FIRE, EXPLOSION, PERSONAL INJURY OR DEATH AND EXTENSIVE PROPERTY DAMAGE.
- TURN OFF ALL GAS AND ELECTRIC POWER SUPPLIES TO THE BOILER BEFORE SERVICING. CONTACT WITH OR RELEASE OF DANGEROUS FLAMMABLE GAS, ELECTRICAL VOLTAGE, MOVING PARTS AND VERY HOT WATER UNDER PRESSURE MAY CAUSE SERIOUS PERSONAL INJURY, PROPERTY DAMAGE OR DEATH.
- LOCK ELECTRICAL BOXES AND GAS VALVES CLOSED TO PREVENT SOMEONE FROM INADVERTENTLY RESTORING POWER OF GAS BEFORE THE HEATING SYSTEM IS SAFE TO OPERATE.
- WATER LEAKS CAN CAUSE SEVERE CORROSION DAMAGE TO THE BOILER OR OTHER SYSTEM COMPONENTS. REPAIR ANY LEAKS FOUND IMMEDIATELY.

The following routine maintenance should be performed on an annual basis:

- 1) Turn off electrical power and gas supply to the boiler.
- 2) Remove the burner tray. To do this:
  - a) Remove the intake cover.
  - b) Remove the four Allen head screws holding the elbow flange onto the gas valve.
  - c) Remove the three 10-32 screws holding the manifold gasket plate to the intake box.
  - d) Remove the four 5-16 nuts holding the burner tray in the boiler.
  - f) Carefully remove the burner assembly being careful not to damage the firedoor insulation or the manifold gasket.
- 3) Inspect the flue passages for signs of blockage. If there is any carbon in the combustion chamber or the flue passages, clean the heat exchanger before proceeding further. See the cleaning procedure below.
- 4) Remove any debris found in the combustion chamber, being careful not to disturb combustion chamber insulation.
- 5) Inspect and clean the burners. Clean the burners by first brushing the ports with a soft bristle brush and then vacuuming out any debris through the venturi opening. If burners show signs of deterioration, they should be replaced (some discoloration around the burner ports is normal).
- 6) Inspect the pilot assembly. Clean any deposits found on the electrode and grounding strap. The ideal gap between the electrode and the ground strap is 1/8". Inspect the porcelain for cracks or other deterioration. Replace pilot assembly if deterioration is found. Inspect the ignition cable insulation for cracks or other deterioration. If deterioration is found, replace cable assembly.
- 7) Inspect the combustion chamber insulation for deterioration. Replace insulation if necessary.
- 8) Inspect all boiler wiring for loose connections or deterioration.



## WARNING

SOOT DEPOSITS IN THE FLUE PASSAGES ARE A SIGN THAT THE BOILER MAY BE OPERATING AT HIGH CARBON MONOXIDE (CO) LEVELS. AFTER CLEANING THE BOILER OF SOOT DEPOSITS, CHECK THE CO LEVEL IN THE FLUE GAS TO INSURE THAT THE BOILER IS OPERATING PROPERLY.

If it is necessary to check CO, use a combustion analyzer, or other instrument which is designed to measure CO in flue gas. A CO “sniffer” designed for testing CO levels in ambient air cannot be used to check boiler combustion. Take a flue gas sample by inserting a sample probe through the vent terminal. Do not take a sample until the boiler has been firing for at least five minutes. A normal CO reading for an CWD series boiler is less than 50ppm (0.005%). A reading of more than 100ppm (0.01%) is indicative of a combustion problem.

Some causes of excessive CO include:

- Incorrectly sized or drilled burner orifice
- Partially plugged flue passages
- Improper manifold pressure
- Partial blockage of vent or intake system
- Foreign material in burner venturis or burner ports
- Missing regulator cover or disconnected regulator reference tube
- Damaged fan impeller or housing
- Damaged or missing fan gasket
- Leak in seal between flue collector and heat exchanger
- Distorted or missing combustion chamber floor
- Damaged base
- Flue gas leak in the concentric section of the coaxial terminal

9) Inspect the vent system:

- Make sure that the vent system is free of obstructions.
- Make sure that all vent system supports are intact.
- Inspect joints for signs of condensate or flue gas leakage.
- Inspect venting components for corrosion or other deterioration. Replace any defective vent components.

10) Inspect the boiler and hydronic system for leaks.

11) Place the boiler back in operation using the procedure outlined in Part X. Check the pilot line and any other gas piping disturbed during the inspection process for leaks.

### Heat Exchanger Cleaning Procedure

1) Turn off electrical power and gas supply to the boiler.

2) Remove the burner tray. To do this:

- a) Remove the intake cover.
- b) Remove the four Allen head screws holding the elbow flange onto the gas valve.
- c) Remove the three 10-32 screws holding the manifold gasket plate to the intake box.
- d) Remove the four 5-16 nuts holding the burner tray in the boiler.
- e) Carefully remove the burner assembly being careful not to damage the firedoor insulation or the manifold gasket.

3) Disconnect the vent system from the boiler by removing the four 10-32 screws holding the vent collar in place.

4) Remove the top jacket panel. If possible, remove the rear and left side jacket panels.

5) Unplug the fan and remove the fan cover plate.

- 6) Disconnect the pressure switch hoses.
- 7) Loosen the two ¼-20 nuts and washers in the flue collector lugs. Slide the flue collector lugs off of each flue collector flange.
- 8) Score the silicone seal around the flue collector with a utility knife or similar tool.
- 9) Pry the flue collector off of the heat exchanger, being careful not to damage the flue collector or fan.
- 10) Remove the stainless steel flue baffle from each flue passage.
- 11) Clean the flue passageways using a stiff bristle brush. Be certain that all foreign material is removed from the gaps between the pins.
- 12) Clean the bottom surfaces of the heat exchanger.
- 13) Put a light in the combustion chamber and look through the flue passages from the top to verify that they have been thoroughly cleaned.
- 14) Replace the flue baffles.
- 15) Apply a heavy (1/4") bead of silicone with a temperature rating of at least 400F around the perimeter of the heat exchanger.
- 16) Set the flue collector onto the block and press down so that the flue collector is set into the silicone applied in the previous step.
- 17) Slide the flue collector lugs back into position and retighten the ¼-20 bolts. **DO NOT OVER TIGHTEN.**
- 18) Apply a bead of silicone around the outside of the joint between the heat exchanger and the flue collector.
- 19) Reattach all the jacket components.
- 20) Reconnect the pressure switch tubes (see Figure 12.2 for correct tubing orientation).
- 21) Reconnect the fan.
- 22) Reconnect the vent system.
- 23) Reinstall the burner tray.

### Service Notes

- 1) Operating the Boiler with Intake Cover Removed – For inspection and troubleshooting purposes, this boiler may be started and run with the intake cover removed. When this is done, a resonance (“hum”) may be observed. This is normal and should disappear as soon as the intake cover is replaced.



### WARNING

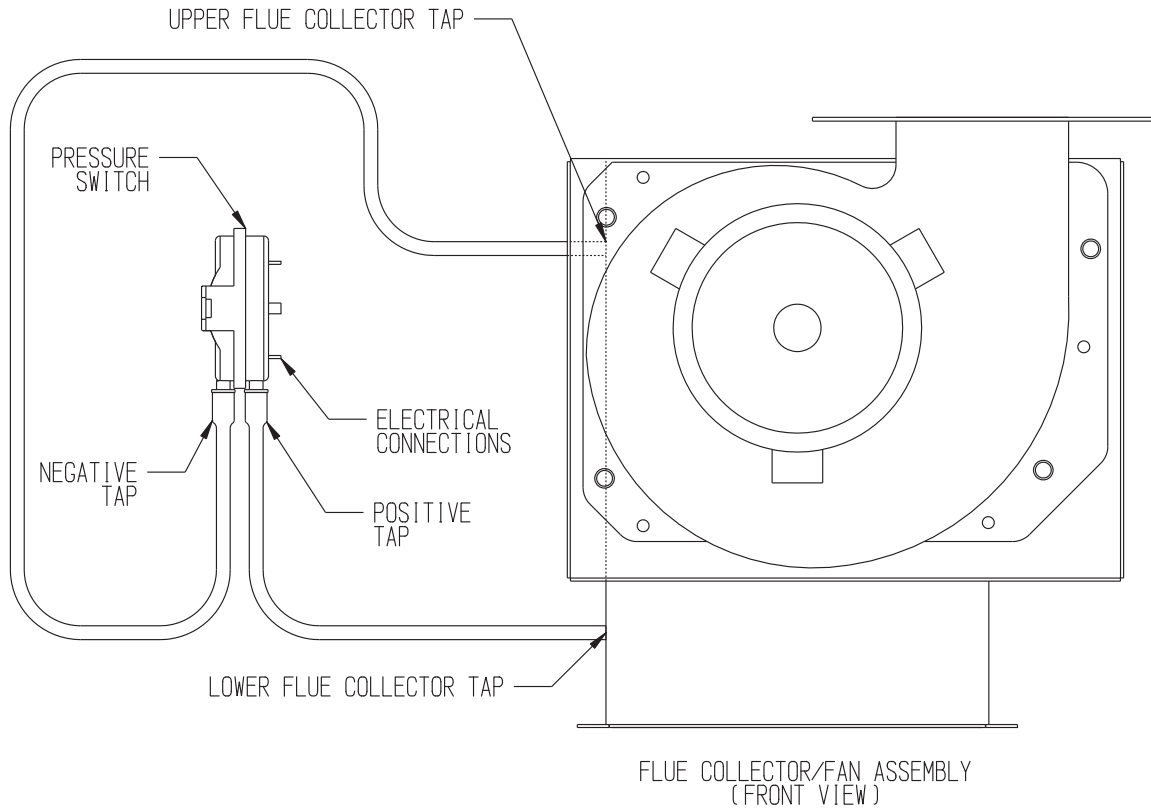
DO NOT LEAVE THE BOILER IN SERVICE WITH THE INTAKE COVER REMOVED.

- 2) Pressure Switch – This boiler is equipped with a differential pressure switch which makes when there is adequate flue gas flow through the boiler. This switch measures the pressure drop across an orifice plate inside the flue collector - the higher the flue gas flow through this plate, the higher the pressure drop. The N.O. contacts on the pressure switch make, allowing the boiler to fire, when the pressure drop across the flue collector orifice plate switch exceeds the “make setting” shown in Table 12.1. Once the switch is made, the boiler will fire as long as the pressure at the switch is above the “break setting” shown in Table 12.1. The pressure at both pressure switch tappings is actually below atmospheric (“negative”) with the pressure at the upper flue collector tap being the more negative of the two pressures. Figure 12.2a shows the pressure switch connections.  
Figure 12.2b shows the correct method of reading the pressure across the pressure switch tappings. It is normal for the pressure reading across the switch to drop as the boiler heats up.
- 3) Burner and Pilot Removal - If necessary, the pilot can be removed without removing the burner tray. To do so, remove the screws holding the main burners on each side of the pilot bracket. The main burners will then be loose enough to allow the pilot hood to slip between them.  
Main burners cannot be removed without removing the burner tray from the boiler.

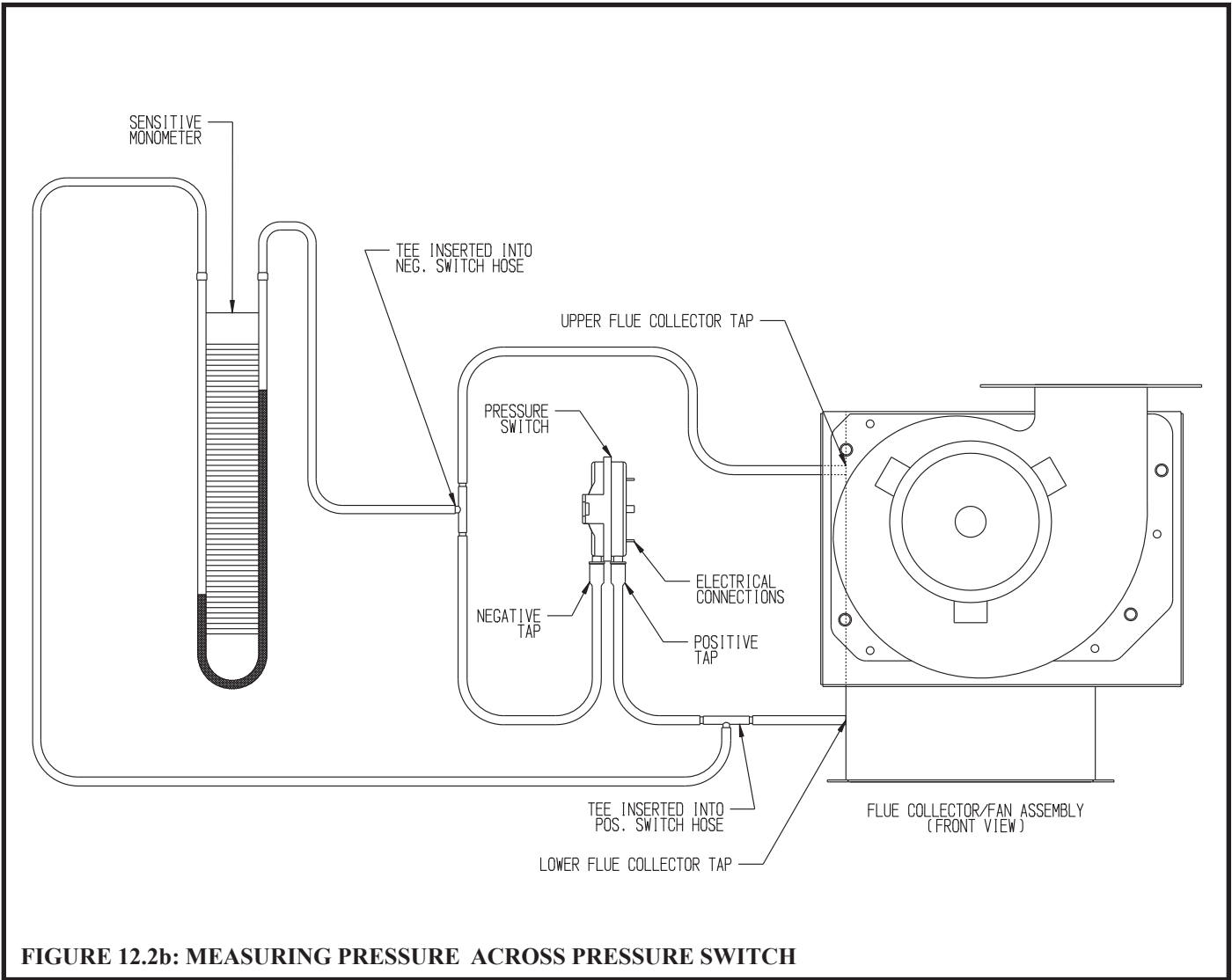
**TABLE 12.1: PRESSURE SWITCH SETTINGS**

MODEL	CROWN PN	APPROX. MAKE SETTING (inches w.c.)	BREAK SETTING* (inches w.c.)
CWD060 - CWD110	620039	1.21	1.16
CWD138 - CWD220	620040	1.40	1.35
CWD245	620041	1.45	1.40

\*Settings shown are based on “plus tolerance” - actual setting may be lower.



**FIGURE 12.2a: PRESSURE SWITCH CONNECTIONS**





## XIII Troubleshooting

### A. Before Troubleshooting

The following pages contain trouble shooting tables for use in diagnosing control problems. When using these tables the following should be kept in mind:

- 1) This information is only meant to be used by a professional heating technician as an aid in diagnosing boiler problems.
- 2) Where applicable, follow all precautions outlined in the Section X (Start-up and Checkout) of the boiler installation manual.
- 3) In general, these tables assume that there are no loose or miswired electrical connections. Before using these tables inspect all electrical connections on the boiler to make sure that they are tight. Also, check the wiring on the boiler against the wiring diagram in Figures 9.2 and 9.3. Ensure that incoming 120 VAC power polarity is correct and that the boiler is properly grounded. Further, ensure that the control power supply is 24 VAC (minimum 18 VAC to maximum 30 VAC).
- 4) All controls on the boiler are tested at least once in the manufacturing process and a defective control or component is generally the least likely cause. Before replacing a component, try to rule out all other possible causes.
- 5) When checking voltage across at wiring connectors be careful not to insert the meter probes into the metal sockets. Doing so may damage the socket, resulting in a loose connection when the harness is reconnected.

### B. If Display is Blank

- 1) Check for 24 VAC on transformer secondary connections (screws to which blue and yellow leads are connected). If voltage across these screws is between 18 and 30 VAC, possible causes include:
  - Loose connection at either plug or transformer end of transformer harness (blue/yellow harness).
  - Defective transformer harness
  - Defective boiler control
- 2) If voltage is less than 18VAC at transfer secondary, possible causes include:
  - Service switch off
  - Trip 120VAC breaker
  - Miswired or loose connection in 120VAC boiler circuit.
  - Loose connection inside J-box between transformer primary and 120VAC line.
  - Defective transformer (possibly caused by short circuit in 24VAC wiring or additional loads connected to the transformer in the field).

### C. If Control Shows *Err* Code

Use Table 13.0 to help identify and correct the cause of the problem.

### D. If Control Shows *5EA* Code, but Other Problem Present

If no *Err* Code is observed (even after repeatedly pressing **I** to cycle through Operation Mode), use Table 13.1 to help identify and correct the cause of the problem.

**TABLE 13.0: ERROR CODES**

Error Code	Meaning	Possible Cause
2	Pressure Switch failed to open	<ul style="list-style-type: none"> <li>Jumped air pressure switch</li> <li>Condensate in air pressure switch or switch tubing</li> <li>Defective air pressure switch</li> </ul>
4	Low Flame Signal	<ul style="list-style-type: none"> <li>Low gas pressure at gas valve inlet</li> <li>Partially plugged pilot tubing or pilot orifice</li> <li>Loose connection in ignition cable or ground wiring</li> <li>Dirty pilot electrode/ground strap</li> <li>Pilot electrode porcelain cracked</li> <li>Damaged pilot hood/ assembly</li> <li>Defective control</li> </ul>
6	Pilot Flame detected when no flame should be present	<ul style="list-style-type: none"> <li>Defective gas valve</li> <li>High gas pressure</li> <li>Defective control</li> </ul>
18	Internal electronics failure	<ul style="list-style-type: none"> <li>Possible internal problem with boiler control. Cycle power to the boiler and replace control if problem persists.</li> </ul>
23	Flame sensed during 30s pre-purge (before pilot valve opened)	<ul style="list-style-type: none"> <li>Defective gas valve</li> <li>High gas pressure</li> <li>Defective control</li> </ul>
29	Air pressure switch failed to close	<ul style="list-style-type: none"> <li>Vent system blockage</li> <li>Vent system not constructed in accordance with installation manual (excessive length, undersized pipe, wrong terminal, etc)</li> <li>Condensate or leakage in air pressure switch tubing</li> <li>Winds in excess of 40mph</li> </ul>
32	Boiler water temperature sensor failure	<ul style="list-style-type: none"> <li>Loose sensor connection at control</li> <li>Defective Sensor</li> <li>Defective control</li> </ul>
35	Duplicate Zone	Error code reserved for future use
57	Grounded pilot electrode	<ul style="list-style-type: none"> <li>Condensate or foreign material is shorting pilot electrode to ground.</li> <li>Ignition cable insulation is damaged and touching ground.</li> <li>Pilot is damaged</li> </ul>
58	AC Power Frequency Error	<ul style="list-style-type: none"> <li>120VAC power supply frequency is incorrect (Should be 60Hz)</li> <li>120VAC power supply is dirty (consult electrician and/or Utility)</li> <li>Boiler water temperature sensor common (center wire) is damaged and shorted to ground</li> </ul>
59	Line voltage error (Supply voltage too high or low)	<ul style="list-style-type: none"> <li>Power supply voltage is incorrect (should be 120VAC nominal)</li> <li>Defective or incorrect 24VAC transformer</li> <li>Loose 120VAC connection or 24VAC connection between transformer and control</li> </ul>
60	Thermostat input higher than threshold	<ul style="list-style-type: none"> <li>External voltage is applied to thermostat connections (most common cause is external transformer in old thermostat wiring.</li> </ul>
61	Line Voltage Unstable	<ul style="list-style-type: none"> <li>120VAC power supply is dirty (consult electrician and/or Utility)</li> <li>Loose 120VAC connection or 24VAC connection between transformer and control</li> <li>Large electrical loads elsewhere on the installation are switching on and off, causing incoming voltage to swing excessively at boiler.</li> </ul>
63	Maximum recycles exceeded	<ul style="list-style-type: none"> <li>See Error Code 4 above (boiler lost proof of pilot 6 times in a row)</li> </ul>
64	Internal failure	<ul style="list-style-type: none"> <li>Improper pilot operation</li> <li>If problem persists, replace control</li> </ul>
89	EnviraCom communication lost	Should not be observed on BWF or CWD Series Boilers.

**TABLE 13.1: FAULTS WITHOUT ERROR CODE PRESENT**

Displayed Codes	Problem	Possible Cause
StA 1 ht OFF dh OFF	Burners and Circulator Off	<ul style="list-style-type: none"> <li>• Thermostat/s not calling for heat</li> <li>• Loose connection in thermostat, zone valve end switch, or zone panel wiring.</li> <li>• Thermostat, zone valve, or zone panel miswired</li> <li>• Defective thermostat, zone valve, or zone panel</li> </ul>
StA 1 ht On	Burners Off Circulator On Boiler Warm	<ul style="list-style-type: none"> <li>• Boiler off on high limit (normal operation)</li> <li>• Boiler off on thermal purge (normal operation - See Table 11.7)</li> </ul>
ht On	Heating Circulator Off	<ul style="list-style-type: none"> <li>• Heating Circulator is being forced off on DHW priority (normal operation if Pt=ON - see Table 11.8).</li> <li>• See causes for “DHW Circulator off“ below</li> </ul>
dh On	DHW Circulator Off	<ul style="list-style-type: none"> <li>• Loose connection in circulator wiring</li> <li>• Defective circulator</li> <li>• Circulator is running, but system problem is preventing circulation</li> </ul>
StA 15	Burners Off and Fan is Off.	<ul style="list-style-type: none"> <li>• Limit or LWCO connected to Option Plug is open.</li> <li>• No option is connected at the Option Plug and jumper plug (PN 9601830 ) is missing.</li> <li>• Flame roll-out switch (FRS) open due to blocked heat exchanger. Correct problem and replace FRS with exact replacement (see parts list)</li> </ul>
StA 6	No spark at pilot	<ul style="list-style-type: none"> <li>• Loose connection in ignition cable or pilot ground</li> <li>• Damaged electrode porcelain or ignition wire insulation (replace pilot)</li> <li>• Pilot electrode or Ground strap damaged (replace pilot)</li> <li>• If you cannot hear spark at all, replace control</li> </ul>
StA 6	Spark, but no pilot flame	<ul style="list-style-type: none"> <li>• Low inlet gas pressure</li> <li>• Plugged, kinked, or leaking pilot tubing</li> <li>• Plugged pilot orifice</li> <li>• Gas line not purged of air</li> <li>• Defective pilot assembly</li> <li>• Defective gas valve (before replacing, confirm that there is 24VAC between PV and MV/PV. If there is not, control harness is loose or the control itself is defective).</li> <li>• Loose connection in harness between control and gas valve.</li> </ul>
StA 6	Pilot flame present, but spark does not shut off	<ul style="list-style-type: none"> <li>• Low inlet gas pressure</li> <li>• Partially plugged, kinked, or leaking pilot tubing</li> <li>• Partially plugged pilot orifice</li> <li>• Loose connection in ignition cable or pilot ground</li> <li>• Damaged electrode porcelain or ignition wire insulation (replace pilot)</li> <li>• Pilot electrode or Ground strap damaged (replace pilot)</li> <li>• Defective Control</li> </ul>
StA 8	Pilot flame present, spark off, but Main Burner does not light at all	<ul style="list-style-type: none"> <li>• Loose connection in harness between control and gas valve</li> <li>• Defective gas valve (before replacing, confirm that there is 24VAC between MV and MV/PV. If there is not either there is a loose connection in the control harness or the control itself is defective).</li> </ul>
StA 10	Main burner lights, but shuts off immediately	<ul style="list-style-type: none"> <li>• Low inlet gas pressure</li> <li>• Partially plugged, kinked, or leaking pilot tubing</li> <li>• Partially plugged pilot orifice</li> </ul>
StA 10 or StA 13	No spark or pilot	<ul style="list-style-type: none"> <li>• Pilot was either never established or proof of pilot was lost after it was lit. Cycle power to the boiler and look for symptoms above.</li> </ul>

## Notes

## XIV PARTS

The following parts may be obtained from any Crown distributor. To find the closest Crown distributor, consult the area Crown representative or the factory at:

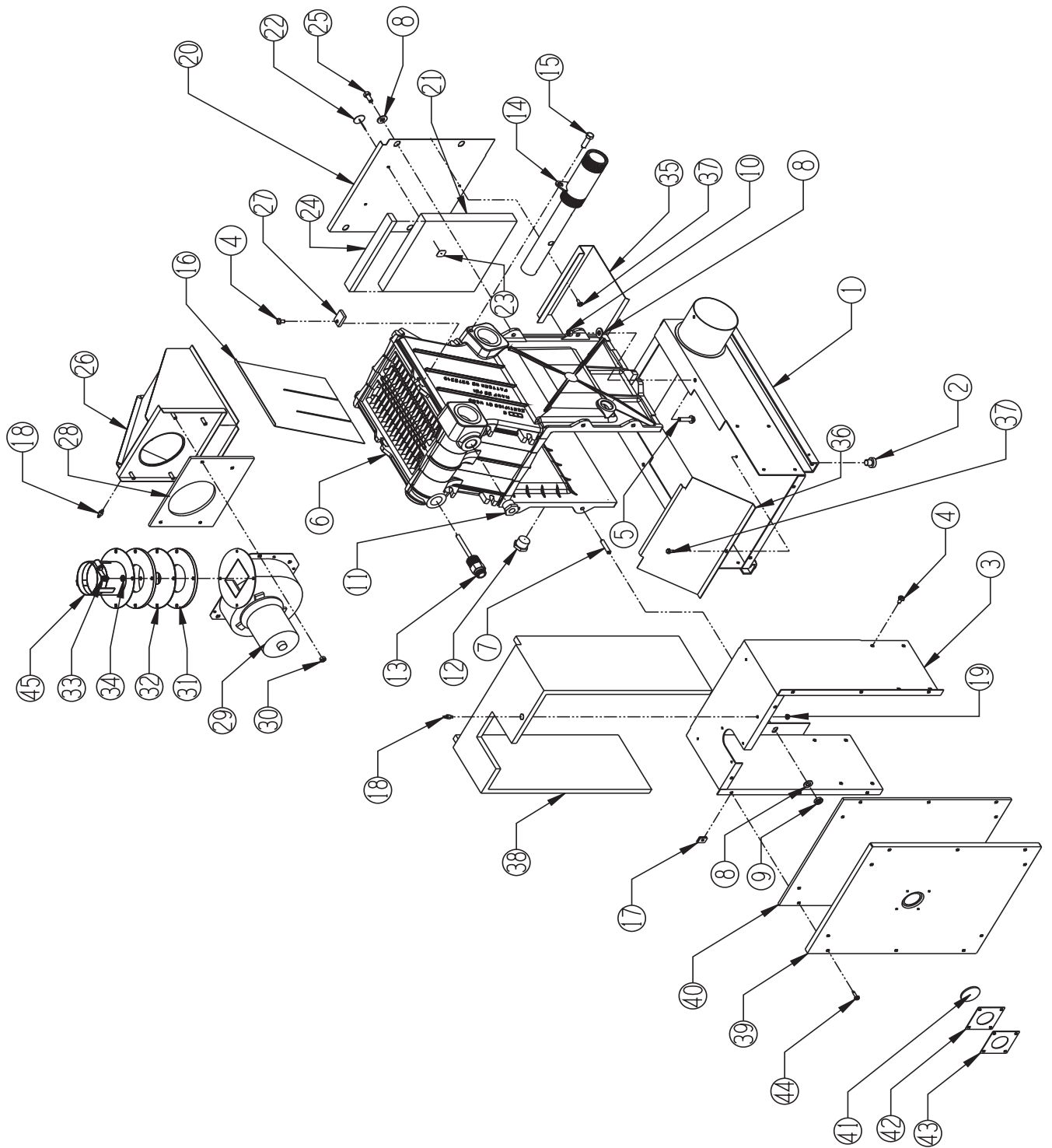
Crown Boiler Co.  
Customer Service  
P.O. Box 14818  
Philadelphia Pa. 19134  
[www.crownboiler.com](http://www.crownboiler.com)

Main burner orifice shown are for sea level configured boilers. For boilers installed at elevations above 2000 ft, consult the local Crown representative or the factory for the correct main burner orifice.

BLOCK, BASE, FLUE COLLECTOR COMPONENTS

KEY	DESCRIPTION	PART # OR QTY.	PART # OR QTY.							
			CWD060	CWD083	CWD110	CWD138	CWD165	CWD193	CWD220	CWD245
1	BASE	1	620113	620114	620115	620116	620117	620118	620119	620120
2	NYLON FEET (GLIDES)	700111	4	4	4	4	4	4	4	4
3	INTAKE BOX	1	620233	620234	620235	620236	620237	620238	620239	620240
4	1/4-20 X1/2 PAN HEAD SCREW	900100	14	14	14	14	14	14	14	14
5	5/16-18 X 1 1/4 TAP BOLT	900101	2	2	2	2	2	2	2	2
6	COMPLETE CAST IRON BLOCK ASSEMBLY	1	620013	620014	620015	620016	620017	620018	620019	620020
*	LEFT END SECTION	620011	1	1	1	1	1	1	1	1
*	INTERMEDIATE SECTION	620006	1	2	3	4	5	6	7	8
*	RIGHT END SECTION	620012	1	1	1	1	1	1	1	1
*	PUSH NIPPLE	620008	4	6	8	10	12	14	16	18
7	5/16-18 X 1 1/2 FULLY THREADED ZINC PLATED STUDS	900425	4	4	4	4	4	4	4	4
8	5/16 USS FLAT WASHER	900102	14	14	14	14	14	14	14	14
9	5/16-18 S,S HEX NUT	90-010	8	8	8	8	8	8	8	8
10	5/16-18 NYLON INSERT HEX NUT	900103	2	2	2	2	2	2	2	2
11	3/4 X 1/4 BLACK IRON REDUCING BUSHING	950017	1	1	1	1	1	1	1	1
12	3/4 IN BLACK IRON PLUG	95-048	2	2	2	2	2	2	2	2
13	3/4" HIGH LIMIT WELL	35-1010	1	1	1	1	1	1	1	1
14	CWD DISTRIBUTOR PIPE	1	620143	620144	820145	620146	620147	620148	620149	620150
15	3/8-16 X 1 1/4 ZINC PLATED HEX HEAD CAP SCREW	900452	1	1	1	1	1	1	1	1
16	FLUE BAFFLE	620100	2	3	4	5	6	7	8	9
17	TINNERMAN NUT	90-217	10	10	12	12	12	12	12	12
18	10-32 X 1/8 I.D.HOSE BARB	90-222	3	3	3	3	3	3	3	3
19	10-32 HEX NUT	90-219	3	3	3	3	3	3	3	3
20	REAR FIREDOOR	1	620203	620204	620205	620206	620207	620208	620209	620210
21	REAR FIREDOOR INSULATION	1	620533	620534	620535	620536	620537	620538	620539	620540
22	1 1/4 CUP HEAD PIN	900203	4	4	6	6	6	6	6	6
23	1 1/4 SELF LOCKING WASHER	900200	4	4	6	6	6	6	6	6
24	1" CERAFELT SEALING STRIP	900145	0.75 FT	1.05 FT	1.35 FT	1.65 FT	1.95 FT	2.25FT	2.55 FT	2.85 FT
25	5/16-18 X 3/4 HEX CAP SCREW	900400	4	4	4	4	4	4	4	4
26	FLUE COLLECTOR	1	620123	620124	620125	620126	620127	620128	620129	620130
27	FLUE COLLECTOR LUG	60-501	2	2	2	2	2	2	2	2
28	FAN GASKET	1	620002	620002	620002	650002	650002	650002	650002	650002
29	FAN ASSEMBLY	1	620001	620001	620001	60-001	60-001	60-001	60-001	60-001
*	REPLACEMENT FAN CAPACITOR	1	620003	620003	620003	60-003	60-003	60-003	60-003	60-003
30	1/4-20 HEX NUT	90-202	4	4	4	4	4	4	4	4
31	COLLAR GASKET	2	620603	620603	620603	620603	620603	620602	620602	620602
32	FAN OUTLET ORIFICE	1	620133	650136	620135	620136	620137	620139	650137	650138
33	10-32 X1/2 SLOTTED ROUND SCREW	90-058	6	6	6	6	6	6	6	6
34	#10 FLAT WASHER	90-057	4	4	4	4	4	4	4	4
35	COMB CHAMBER FLOOR	1	620223	620224	620225	620226	620227	620228	620229	620230
36	DISTRIBUTOR SCREEN	1	620253	620254	620255	620256	620257	620258	620259	620260
37	10-32 X1/2 SLOTTED HEX WASHER SCREW, TYPE "F", ZINC PLATED	900155	25	31	37	43	49	55	61	67
38	INTAKE BOX INSULATION	1	620553	620554	620555	620556	620557	620558	620559	620560
39	INTAKE COVER	1	620213	620214	620215	620216	620217	620218	620219	620220
40	INTAKE COVER GASKET	1	620613	620614	620615	620616	620617	620618	620619	620620
41	SIGHT GLASS	60-052	1	1	1	1	1	1	1	1
42	SIGHT GLASS GASKET	60-056	1	1	1	1	1	1	1	1
43	SIGHT GLASS FRAME	60-055	1	1	1	1	1	1	1	1
44	#10 X 3/4 HEX HEAD TYPE "B" SCREW	90-054	10	10	12	12	12	12	12	12
45	3 " VENT COLLAR	60-603	1	1	1	1	1	1	0	0
45	4" VENT COLLAR	60-604	0	0	0	0	1	1	1	1
*	10.1 oz TUBE SILICONE SEALANT	90-045	1	1	1	1	1	1	1	1

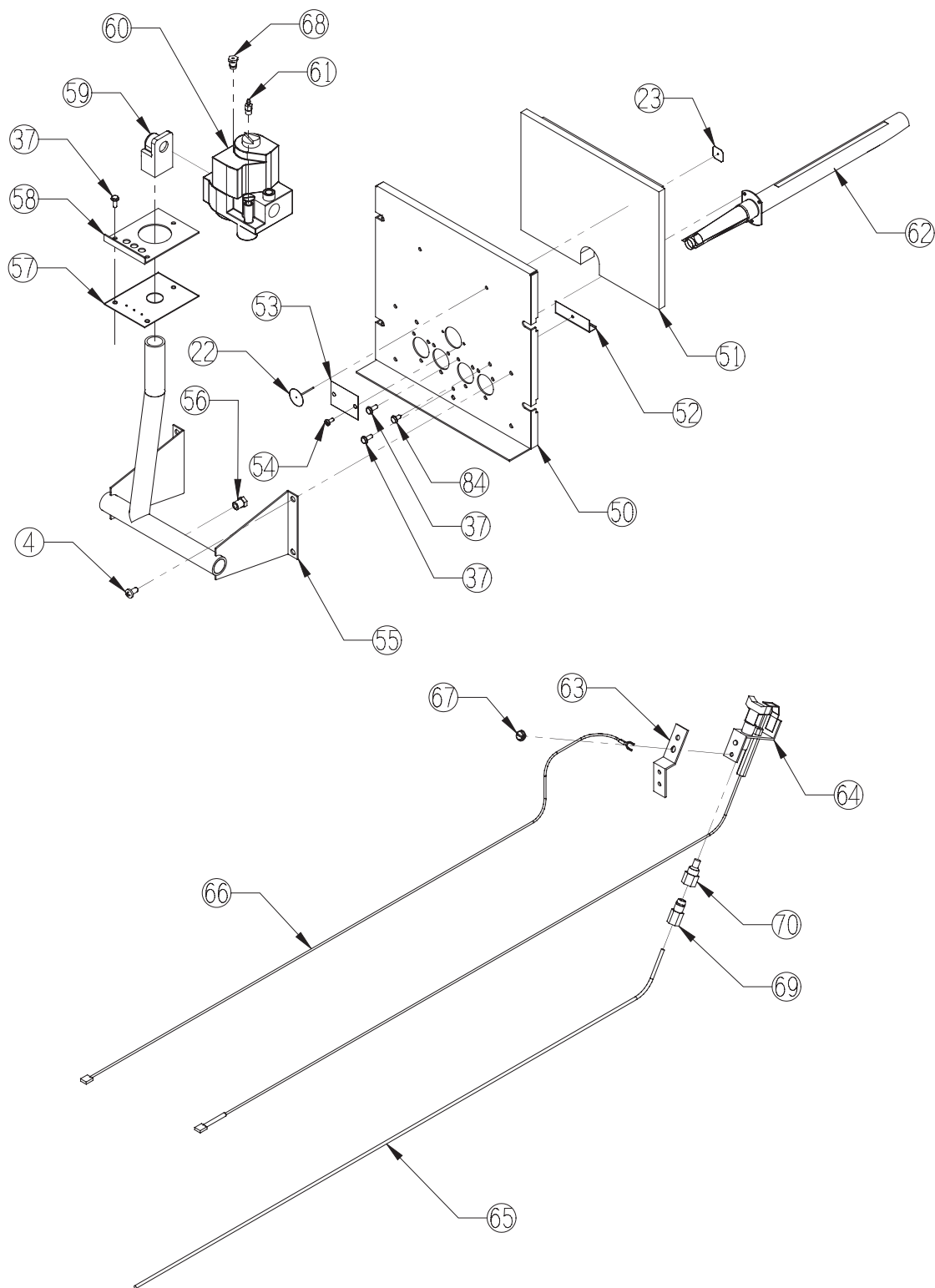
\* NOT PICTURED



## BURNER TRAY COMPONENTS

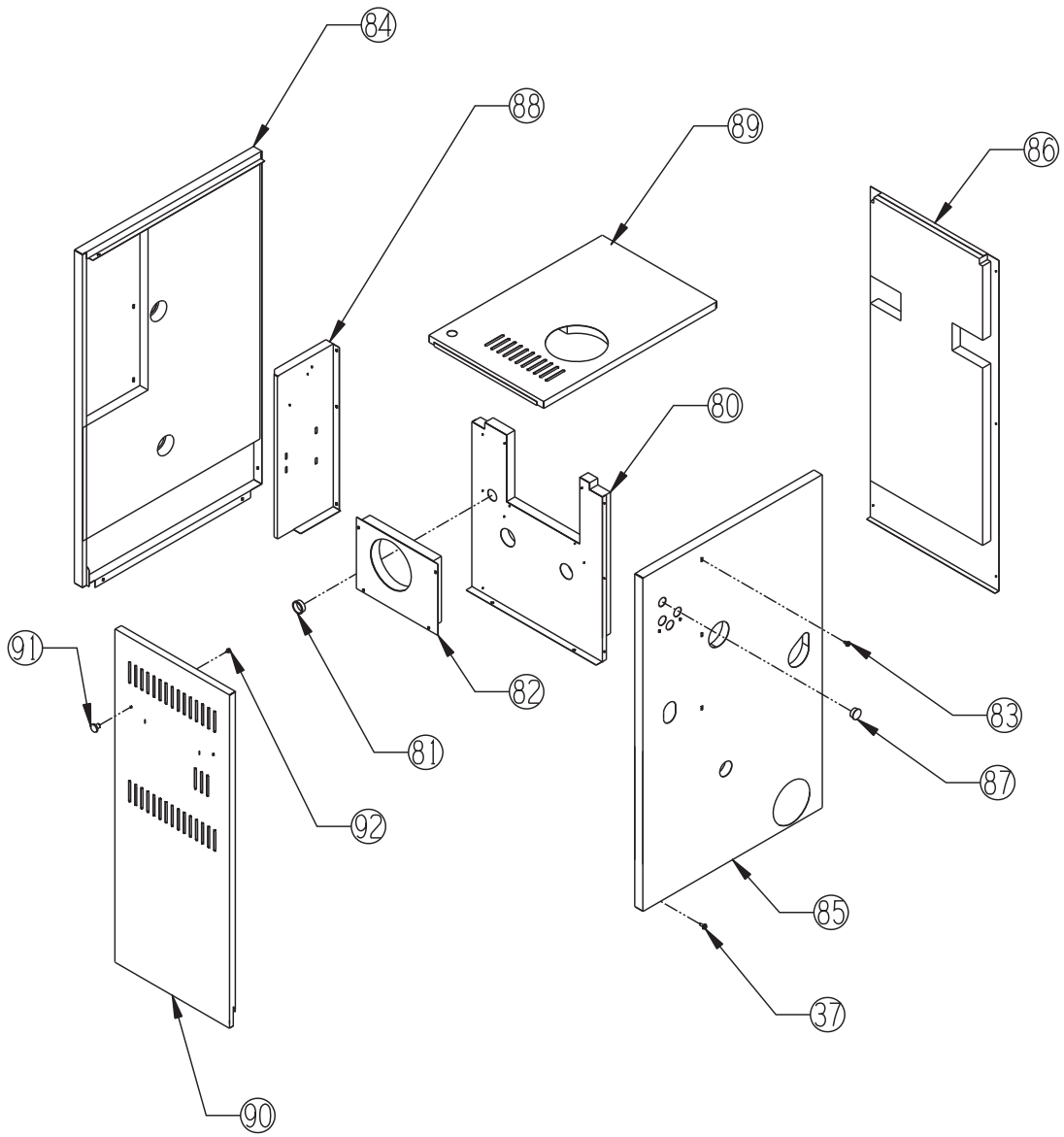
KEY	DESCRIPTION	PART# OR QTY.	PART # OR QTY.							
			CWD060	CWD083	CWD110	CWD138	CWD165	CWD193	CWD220	CWD245
50	FRONT FIREDOOR	1	620543	620544	620545	620546	620547	620548	620549	620550
51	FRONT FIREDOOR INSULATION	1	620523	620524	620525	620526	620527	620528	620529	620530
52	INSULATION SUPPORT BRACKET	620101	2	2	2	2	2	4	4	4
53	MICA SIGHT GLASS	60-050	1	1	1	1	1	1	1	1
54	1/8 ALUMINUM POP RIVET	90-068	2	2	2	2	2	2	2	2
55	BURNER MANIFOLD	1	620153	620154	620155	620156	620157	620158	620159	620160
56	#49 ORIFICE (SEA LEVEL, NAT GAS)	950305	4	0	0	0	0	0	0	0
56	#50 ORIFICE (SEA LEVEL, NAT GAS)	950306	0	6	8	10	12	14	16	18
56	#56 ORIFICE (SEA LEVEL, LP GAS)	950331	4	0	0	0	0	0	0	0
56	#57 ORIFICE (SEA LEVEL, LP GAS)	950332	0	6	8	10	12	14	16	18
57	MANIFOLD GASKET	60-151	1	1	1	1	1	1	1	1
58	MANIFOLD GASKET PLATE	60-150	1	1	1	1	1	1	1	1
59	3/4" 90 DEGREE FLANGE	35-1055	1	1	1	1	1	1	1	1
60	HONEYWELL VR8204C2328 GAS VALVE (NAT GAS)	3507400	1	1	1	1	1	0	0	0
60	HONEYWELL VR8304P2342 GAS VALVE (NAT GAS)	3507410	0	0	0	0	0	1	1	1
60	HONEYWELL VR8204P2294 GAS VALVE (LP GAS)	3507405	1	1	1	1	1	0	0	0
60	HONEYWELL VR8304P3522 GAS VALVE (LP GAS)	3507245	0	0	0	0	0	1	1	1
61	1/8" GAS VALVE HOSE BARB HW#394537	35-1060	1	1	1	1	1	1	1	1
62	BECKETT GAS BURNERS	150620	4	6	8	10	12	14	16	18
63	PILOT BRACKET	150625	1	1	1	1	1	1	1	1
64	Q3481B1131 PILOT ASSEMBLY (NAT GAS) - INCLUDES IGNITION CABLE	3504100	1	1	1	1	1	1	1	1
64	Q3481B1149 PILOT ASSEMBLY (LP GAS) - INCLUDES IGNITION CABLE	3504105								
65	30" X 1/8" PILOT TUBING	90-043	1	1	1	1	1	1	1	1
66	IGNITION GROUND HARNESS	9601101	1	1	1	1	1	1	1	1
67	10-32 X 3/16 HEX HEAD PILOT SCREW	146-95-301	1	1	1	1	1	1	1	1
68	1/8 SHORT FERRULE (INCLUDED WITH GAS VALVE)	35-1600								
69	1/8 LONG FERRULE (INCLUDED WITH PILOT ASSY.)	35-1650								
70	KF24 PILOT ORIFICE (NAT GAS) - INCLUDED WITH PILOT ASSY.		1	1	1	1	1	1	1	1
70	K14 PILOT ORIFICE (LP GAS) - INCLUDED WITH PILOT ASSY.		1	1	1	1	1	1	1	1





### JACKET COMPONENTS

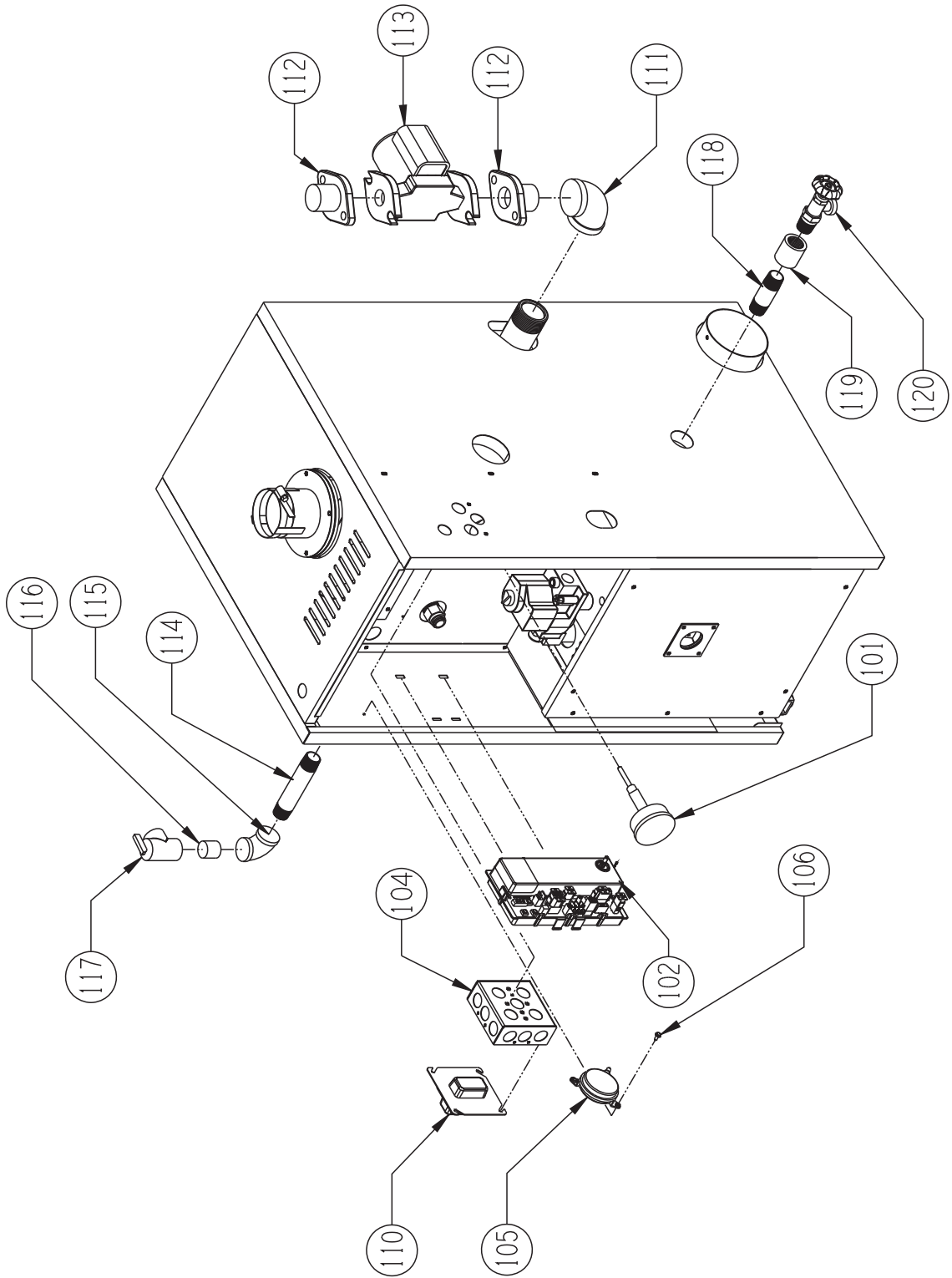
KEY	DESCRIPTION	PART# OR QTY	PART # OR QTY							
			CWD060	CWD083	CWD110	CWD138	CWD165	CWD193	CWD220	CWD245
80	VESTIBULE PANEL	1	620323	620324	620325	620326	620327	620328	620329	620330
81	LARGE PLASTIC BUSHING	960051	1	1	1	1	1	1	1	1
82	FAN COVER PLATE	1	620302	620302	620302	60-300	60-300	60-300	60-300	60-300
83	#10 X 1/2 SHEET METAL SCREW	90-212	31	31	32	31	34	36	36	36
84	LH JACKET PANEL	620301	1	1	1	1	1	1	1	1
85	RH JACKET PANEL	620300	1	1	1	1	1	1	1	1
86	REAR JACKET PANEL	1	620303	620304	620305	620306	620307	620308	620309	620310
87	PLASTIC BUSHING	96-050	2	2	2	2	2	2	2	2
88	CONTROL PANEL	620355	1	1	1	1	1	1	1	1
89	TOP JACKET PANEL	1	620323	620324	620325	620326	620327	620328	620329	620330
90	CWD FRONT JACKET PANEL	1	620313	620314	620315	620316	620317	620318	620319	620320
91	DOOR KNOB	90-210	2	2	2	2	2	2	2	2
92	8-32 X 1/4 MACH. SCREWS	90-211	2	2	2	2	2	2	2	2



## CONTROLS & TRIM

KEY	DESCRIPTION	PART# OR QTY	PART # OR QTY							
			CWD060	CWD083	CWD110	CWD138	CWD165	CWD193	CWD220	CWD245
*	1/8" SILICONE TUBING	14-008	2.5 FT	2.5 FT	2.5 FT	2.5 FT	2.5 FT	2.5 FT	2.5 FT	2.5 FT
101	TRIDICATOR GAUGE	95-069	1	1	1	1	1	1	1	1
102	INTEGRATED BOILER CONTROL (INDUCED DRAFT) (HONEYWELL S9361A2077)	3505065	1	1	1	1	1	1	1	1
*	12" SENSOR (HONEYWELL 50001464-001/B)	350076	1	1	1	1	1	1	1	1
*	SENSOR CLAMP (HONEYWELL)	350077	1	1	1	1	1	1	1	1
104	4X4 JUNCTION BOX	96-055	1	1	1	1	1	1	1	1
105	SEA LEVEL PRESSURE SWITCH (ALL SIZES)	1	620039	620039	620039	620040	620040	620040	620040	620041
106	#8 X1/2 SHEETMETAL SCREWS	900130	2	2	2	2	2	2	2	2
110	TRANSFORMER-AT72D1006	35-2100	1	1	1	1	1	1	1	1
111	1 1/2 X 1 1/4 BLACK 90 DEGREE ELBOW	950200	1	1	1	1	1	1	1	1
112	ISOLATION FLANGE SET	95-061	1	1	1	1	1	1	1	1
113	TACO 007 CIRCULATOR	95-012	1	1	1	1	1	1	1	1
114	3/4" X 5" NIPPLE	95-044	1	1	1	1	1	1	1	1
115	3/4" 90 DEGREE ELBOW	95-057	1	1	1	1	1	1	1	1
116	3/4" CLOSE NIPPLE	95-105	1	1	1	1	1	1	1	1
117	3/4" ASME RELIEF VALVE	95-040	1	1	1	1	1	1	1	1
118	3/4" X 4 1/2" NIPPLE	95-102	1	1	1	1	1	1	1	1
119	3/4" COUPLING	95-056	1	1	1	1	1	1	1	1
120	3/4" BOILER DRAIN	95-041	1	1	1	1	1	1	1	1
*	FAN ADAPTER HARNESS	9601860	1	1	1	1	1	1	1	1
*	BOILER CONTROL HARNESS	9601870	1	1	1	1	1	1	1	1
*	POWER & CIRC. HARNESS	1	9601841	9601841	9601842	9601842	9601842	9601842	9601842	9601842
*	TRANSFORMER HARNESS	1	9601856	9601856	9601857	9601857	9601857	9601857	9601857	9601857
*	LIMIT JUMPER PLUG	9601830	1	1	1	1	1	1	1	1

\* NOT PICTURED



## **Appendix A: Special Requirements For Side-Wall Vented Appliances In The Commonwealth of Massachusetts**

### **IMPORTANT**

The Commonwealth of Massachusetts requires compliance with regulation 248 CMR 4.00 and 5.00 for installation of side-wall vented gas appliances as follows:

1. For direct-vent appliances, mechanical-vent heating appliances or domestic hot water equipment, where the bottom of the vent terminal and the air intake is installed below four feet above grade the following requirements must be satisfied:
  - a. If there is not already one present, on each floor level where there are bedroom(s), a carbon monoxide detector and alarm shall be placed in the living area outside the bedroom(s). The carbon monoxide detector shall comply with NFPA 720 (2005 Edition).
  - b. A carbon monoxide detector shall be located in the room that houses the appliance or equipment and shall:
    - i. Be powered by the same electrical circuit as the appliance or equipment such that only one service switch services both the appliance and the carbon monoxide detector;
    - ii. Have battery back-up power;
    - iii. Meet ANSI/UL 2034 Standards and comply with NFPA 720 (2005 Edition); and
    - iv. Have been approved and listed by a Nationally Recognized Testing Laboratory as recognized under 527 CMR.
  - c. A product-approved vent terminal must be used, and if applicable, a product-approved air intake must be used. Installation shall be in strict compliance with the manufacturer's instructions. A copy of the installation instructions shall remain with the appliance or equipment at the completion of the installation.
  - d. A metal or plastic identification plate shall be mounted at the exterior of the building, four feet directly above the location of the vent terminal. The plate shall be of sufficient size to be easily read from a distance of eight feet away, and read "Gas Vent Directly Below".
2. For direct-vent appliances, mechanical-vent heating appliances or domestic hot water equipment, where the bottom of the vent terminal and the air intake is installed above four feet above grade the following requirements must be satisfied:
  - a. If there is not already one present, on each floor level where there are bedroom(s), a carbon monoxide detector and alarm shall be placed in the living area outside the bedroom(s). The carbon monoxide detector shall comply with NFPA 720 (2005 Edition).
  - b. A carbon monoxide detector shall :
    - i. Be located in the room that houses the appliance or equipment
    - ii. Be either hard-wired or battery powered or both; and
    - iii. Comply with NFPA 720 (2005 Edition)
  - c. A product-approved vent terminal must be used, and if applicable, a product-approved air intake must be used. Installation shall be in strict compliance with the manufacturer's instructions. A copy of the installation instructions shall remain with the appliance or equipment at the completion of the installation.

## Notes



---

Manufacturer of Hydronic Heating Products  
P.O. Box 14818 3633 I. Street  
Philadelphia, PA 19134  
[www.crownboiler.com](http://www.crownboiler.com)

PN 980060  
CWDMANV7  
12/13